



WINTER – 15 EXAMINATION

Subject Code: **17526 (Automobile Engineering) Model Answer**

Important Instructions to examiners:

- 1) The answers should be examined by key words and not as word-to-word as given in the model answer scheme.
- 2) The model answer and the answer written by candidate may vary but the examiner may try to assess the understanding level of the candidate.
- 3) The language errors such as grammatical, spelling errors should not be given more Importance (Not applicable for subject English and Communication Skills).
- 4) While assessing figures, examiner may give credit for principal components indicated in the figure. The figures drawn by candidate and model answer may vary. The examiner may give credit for any equivalent figure drawn.
- 5) Credits may be given step wise for numerical problems. In some cases, the assumed constant values may vary and there may be some difference in the candidate's answers and model answer.
- 6) In case of some questions credit may be given by judgement on part of examiner of relevant answer based on candidate's understanding.
- 7) For programming language papers, credit may be given to any other program based on equivalent concept.

Q1.A (a)

Functions of transmission system of an automobile like, (1M per point)

- i. To transmit power from the engine to the rear wheels of the VEHICLE,
- ii. To make reduced speed available, to rear wheels of the VEHICLE,
- iii. To alter the ratio of wheel speed and engine speed/torque in order to suit the field conditions and
- iv. To transmit power through right angle drive, because the crankshaft and rear axle are normally at right angles to each other.

Q1.A (b)

Advantages of Rear Wheel Drive like, (any four @ 1m per advantage) -

- i) Better handling in dry conditions - accelerating force is applied to the rear wheels, on which the down force increases, due to load transfer in acceleration, making the rear tires better able to take simultaneous acceleration and curving than the front tires.



WINTER – 15 EXAMINATION

Subject Code: **17526 (Automobile Engineering) Model Answer**

- ii) **More predictable steering** in low traction conditions (i.e.: ice or gravel) because the steering wheels maintain traction and the ability to affect the motion of the vehicle even if the drive wheels are slipping.
- iii) **Less costly and easier maintenance** - Rear wheel drive is mechanically simpler and typically does not involve packing as many parts into as small a space as does front wheel drive, thus requiring less disassembly or specialized tools in order to replace parts.
- v) **Even weight distribution** - The division of weight between the front and rear wheels has a significant impact on a car's handling, and it is much easier to get a 50/50 weight distribution in a rear wheel drive car than in a front wheel drive car, as more of the engine can lie between the front and rear wheels (in the case of a **mid engine** layout, the entire engine), and the transmission is moved much farther back.
- vi) **Steering radius** - As no complicated drive shaft joints are required at the front wheels, it is possible to turn them further than would be possible using front wheel drive, resulting in a smaller steering radius.
- vii) **Towing** - Rear wheel drive puts the wheels which are pulling the load closer to the point where a trailer articulates, helping steering, especially for large loads.
- vii) **Weight transfer** during acceleration. (During heavy acceleration, the front end rises, and more weight is placed on the rear, or driving wheels).

Q 1 A (C) Requirements of steering system (Any four 04 marks)

- a) The front wheels should roll without lateral skid while negotiating a curve.
- b) There should be proper proportion between the angles turned by the front wheels.
- c) The tyres must have good elasticity so that on turns these may follow an arc of greater radius than stiff tyres.
- e) The wheels must automatically come to the straight ahead position after negotiating the bend.
When going straight, the wheels must maintain the neutral position.
- f) The angular oscillation of the wheels must be minimum.
- g) The system must be irreversible to a certain degree so that minimum front wheels shocks are transmitted to driver's hand.

WINTER – 15 EXAMINATION

Subject Code: 17526 (Automobile Engineering) Model Answer

Q1.A (d) (@ 2m per explanation)

i) **king pin inclination:**

The angle between the vertical line and center of the king pin or steering axle, when viewed from the front of the wheel is known as steering axle inclination or **king pin inclination**.

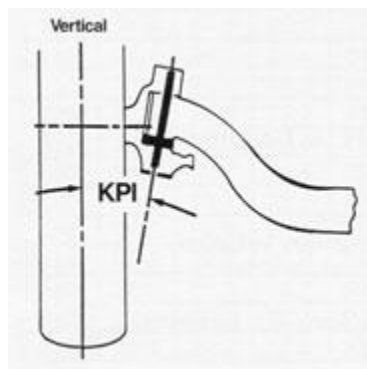

Effect:

- KPI helps the straight head recovery thus directional stability.
- ii) Camber angle- Camber is the angle of the wheels, relative to the road, looking at the car from the front (or rear).

ii) CAMBER; Tilt of car wheel from the vertical. generally will be around - 0.5 to - 5.5 degrees. (negative)

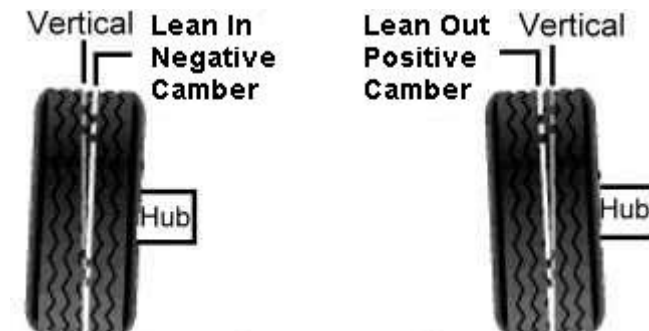



WINTER – 15 EXAMINATION

Subject Code: **17526 (Automobile Engineering) Model Answer**

Q1.B (a)

Aerodynamic shape improves performance of vehicle: (six point like given below 6 m)

Automotive aerodynamics is the study of the aerodynamics of road vehicles. Its main goals are reducing drag and wind noise, minimizing noise emission, and preventing undesired lift forces and other causes of aerodynamic instability at high speeds. Air is also considered a fluid in this case. For some classes of racing vehicles, it may also be important to produce down force to improve traction and thus cornering abilities.

- An aerodynamic automobile will integrate the wheel arcs and lights into the overall shape to reduce drag. It will be streamlined. It does not have sharp edges crossing the wind stream above the windshield and will feature a sort of tail called fastback or Kammback or liftback.
- It will have a flat and smooth floor to support the Venturi effect and produce desirable downwards aerodynamic forces. The air that rams into the engine bay, is used for cooling, combustion, and for passengers, then reaccelerated by a nozzle and then ejected under the floor.
- Door handles, the antenna, and roof rails can have a streamlined shape. The side mirror can only have a round fairing as a nose. Air flow through the wheel-bays is said to increase drag (German source) though race cars need it for brake cooling and many cars emit the air from the radiator into the wheel bay.
- An aerodynamic shape of car body is the external shape of car body which will offer least resistance to air motion.
- Frontal area of car & body of car is designed in such a way that front portion is made inclined & body is given smooth curves. This offers a least resistance to air & called as an aerodynamic shape.
- Since there is least air motion resistance due to the aerodynamic shape. Engine load is decreased and there is better fuel efficiency & average.

WINTER – 15 EXAMINATION

Subject Code: 17526 (Automobile Engineering) Model Answer

Q1.B (b)

(Sketch 2 explanation 4m)

A **transfer case** is a part of the drive train of four-wheel-drive, all-wheel-drive, and other multiple powered axle vehicles. The transfer case transfers power from the transmission to the front and rear axles by means of drive shafts. It also synchronizes the difference between the rotation of the front and rear wheels, and may contain one or more sets of low range gears for off-road use.

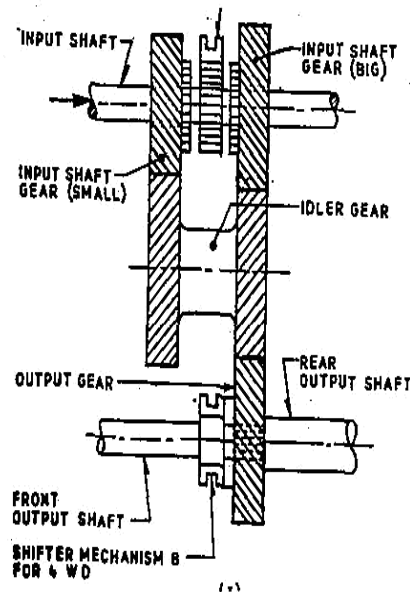

Figure - 04
mark

Transfer case working principle:

- The transfer case is an auxiliary transmission mounted in back of the main transmission. This is used in four wheel drive vehicles.
- The transfer box enables the driver to drive in two wheel drives on highway or shift to four wheel drives for cross-country operation, to drive in high gear or low gear as required.



WINTER – 15 EXAMINATION

Subject Code: **17526 (Automobile Engineering) Model Answer**

- The input shaft is connected to the gear box and carries on it a neuter having axial teeth. Two input shaft gears are free to rotate on the shaft. Each of these gears have bosses on the side which have axial teeth of the same pitch as the central member on the input shaft.
- Depending upon the movement of the transfer box gear level the central member and thereby the input shaft may be connected either to the small gear or to the big gear.
- There are two output shafts, one going to the front axle and the second going to the rear axle. The front output shaft is smaller in diameter & is supported inside the rear output shaft, which is directly connected to the output gear.

Application: -

- 4 wheel drives jeeps & cars & Trucks.

Q 2 (a)

Auto bodies: (Stating 8 types, 4m)

- Car (sedan / hatch back)
- Jeep
- Truck
- bus
- Delivery van
- Dumper
- Station wagon
- Trailer
- Tanker
- Half body truck
- Pickup van etc

WINTER – 15 EXAMINATION

Subject Code: 17526 (Automobile Engineering) Model Answer

Q 2 (b) Any four points 4 M.

S no	Diaphragm clutch	Coil spring clutch
1	Less affected by centrifugal force	Have tendency to distort in transverse direction at higher speed.
2	More compact means of storing energy	Less compact
3	Load deflection curve is not linear	Load deflection curve is linear
4	Acts as both clamping spring and release lever.	Requires additional clamping accessories like pressure plate.
5	Recommended for higher pressure activation.	Recommended for moderate pressure activation.
6	Eg Truck, bus.	Car, jeep

Q2 (c)

(Sketch 2m construction 2M)



WINTER – 15 EXAMINATION

Subject Code: **17526 (Automobile Engineering) Model Answer**

Relevant explanation should be written.

- Used in light vehicles like cars.
- Occupies small space and uses less number of linkages as compared to worm and worm type.
- Rotary motion of steering wheel is transmitted to the pinion of steering gear. The pinion is in mesh with rack.
- The circular motion of pinion is transferred in to linear rack movement.

Q2 (d).(SKETCH 2 M EXPLANATION 2M)

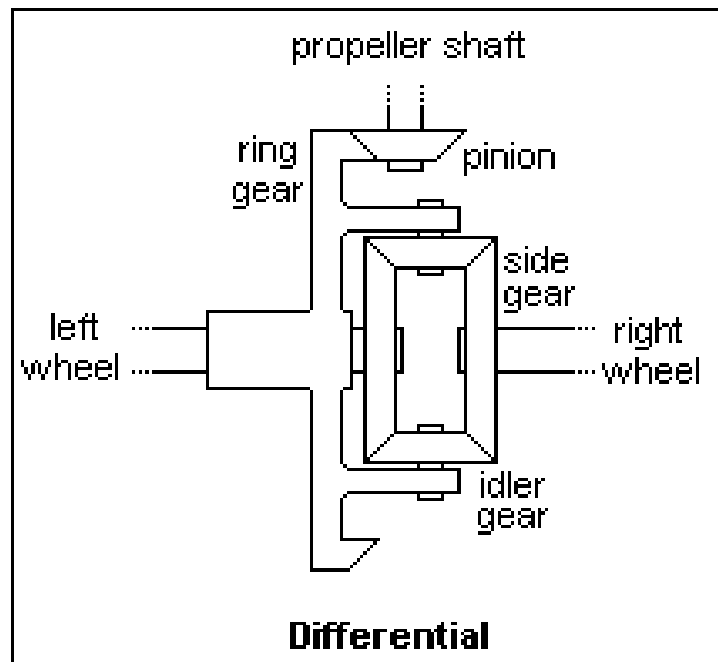

Need of differential:

1. When vehicle is taking turn outer wheel will have to travel greater distance as compared to inner wheel.
2. The vehicle has a solid rear axle only and no other device, there will be tendency to skid.
3. Hence wheel skidding is avoided by incorporating so mechanism i.e. differential.

WINTER – 15 EXAMINATION

Subject Code: **17526 (Automobile Engineering) Model Answer**

4. Differential reduces the speed of inner wheel and increases the speed of outer wheel when vehicle is taking turn, at the same time keep the speed of rear wheel same when going straight ahead.

Q2 (e) Sketch 2 m explanation 2m)

Full floating type of rear axle

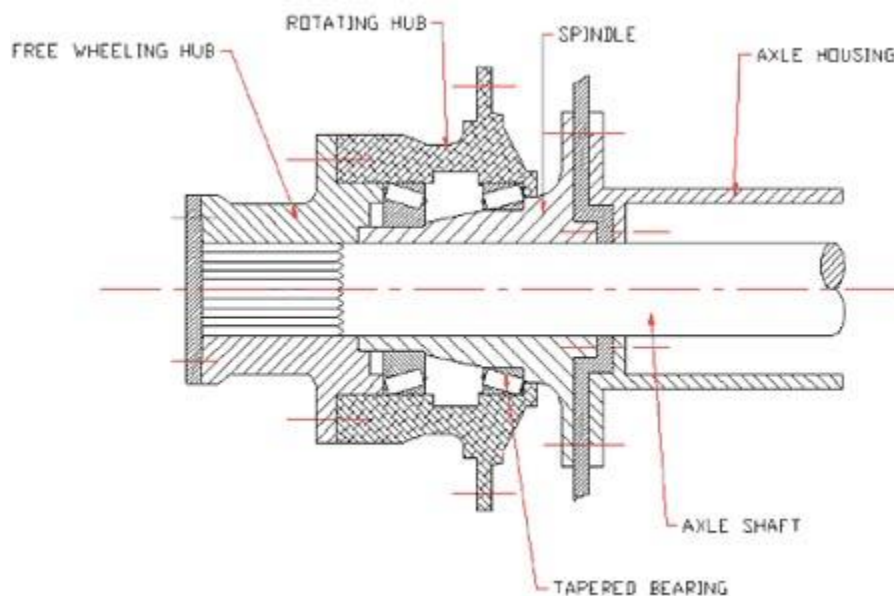

Figure 1: Cross Section of a Full Floater

The rear drive axle connects the differential side gears to the drive wheels. The axle may or may not support the weight of the vehicle. Rear axles are normally induction hardened for increased strength.

The full-floating axle is used in many heavy-duty trucks. The drive wheel is carried on the outer end of the axle housing by a pair of tapered roller bearings. Axle shaft carry only driving torque.

The bearings are located outside the axle housing. In this way, the axle housings take the full weight of the vehicle and absorb all stresses or end thrust caused by turning, skidding, and pulling. Only the axle shaft transmits torque from the differential.

WINTER – 15 EXAMINATION

Subject Code: 17526 (Automobile Engineering) Model Answer

Q 3 Attempt any two of the following (fig=3marks, construction -5 marks)

a) **Synchromesh gear box:-**

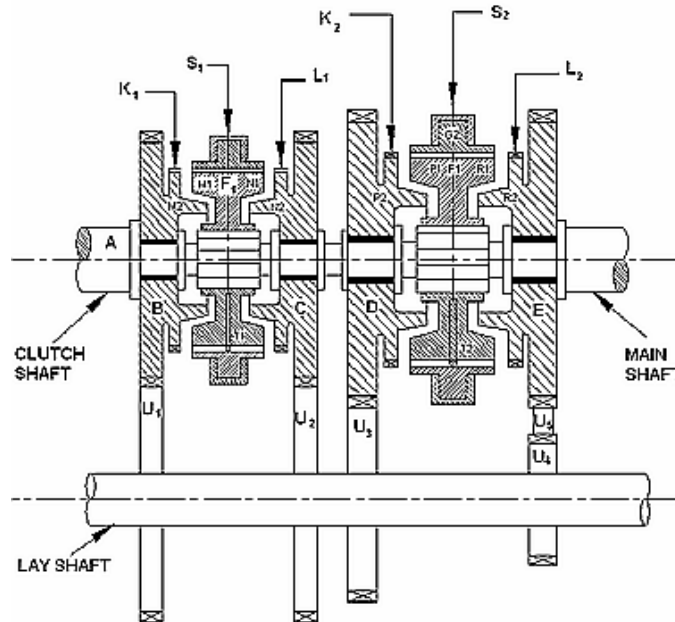

Fig shows the construction and working of a synchromesh gear box. In most of the cars, however, the synchromesh devices are not fitted to all the gears. They are only on the high speed gears but on the low speed and reverse gears, ordinary dog clutches are only provided. This is done to reduce the cost.

In other words, the gear wheels which are to be positively connected are first brought into frictional contact and when the friction has equalized their speeds, the positive connections are made. Synchromesh devices can be applied to the sliding mesh gear box but they are universally used with constant mesh gear boxes used in different motor vehicles. The main features of this gear box are:

- The output gears are free to rotate on bushes on the output shaft. They are internally located by splined thrust bearings. Single or double helical gears remain in constant mesh with the lay shaft gears.
- The output gears are locked to their shaft by the dog clutch
- Change of the synchronizing hub takes place when its speed equalizes or synchronizes by their cones.

In case this gear is not used, it is left to the skill of the driver to bring one or more gears for meshing. By the skillful use of this clutch and accelerator pedal, he can bring the gears

WINTER – 15 EXAMINATION

Subject Code: **17526 (Automobile Engineering) Model Answer**

approximately the same speed. Even for the unskilled driver it is not difficult to affect quite satisfactory the change of gears. He can do it simply by using the clutch pedal gear lever with the help of successful commercial gear synchronizers.

b) **Requirement of steering geometry** :(Relevant points to be considered =4 marks)

- 1) The steering mechanism should be very accurate and easy to handle.
- 2) The effort required to steer should be minimal and must not be tiresome to the driver.
- 3) The steering mechanism should also provide directional stability.
- 4) Vehicle should have a tendency to return to its straight ahead position after turning.

TOE IN TOE OUT:- (4 marks each sketch, significance and explanation)

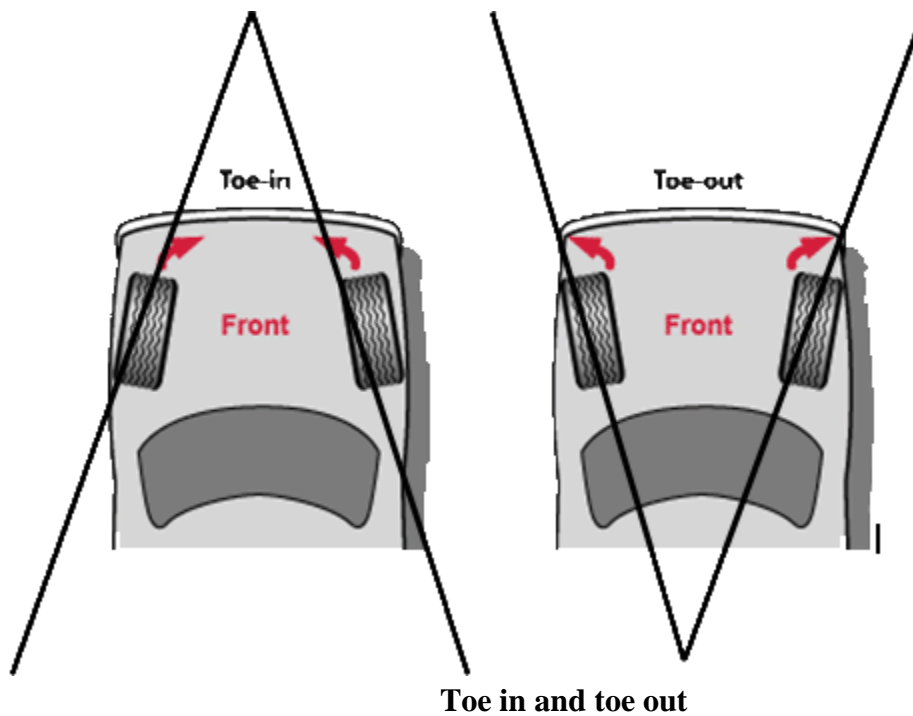

Toe in;

- toe-in is the amount by which the wheels are set closer together at the front than the rear when the vehicle is stationary. Tendency of wheel to toe out hence toe in is provided to front wheel. It does not exceed 3 mm.
- purpose is to move the wheels perfectly straight ahead under running condition.
- It stabilizes steering to prevent sides slipping and excessive wear of tyres.

WINTER – 15 EXAMINATION

Subject Code: 17526 (Automobile Engineering) Model Answer

Toe out;

- It is designed to turn the inside wheel through a larger angle than outside wheel when making a turn.
- Front wheels to toe-out on turns.
- Inside wheel is required to turn to a greater angle than the outer wheel.

C) Hydraulic brake system:-

(Sketch:-4marks working=4marks)

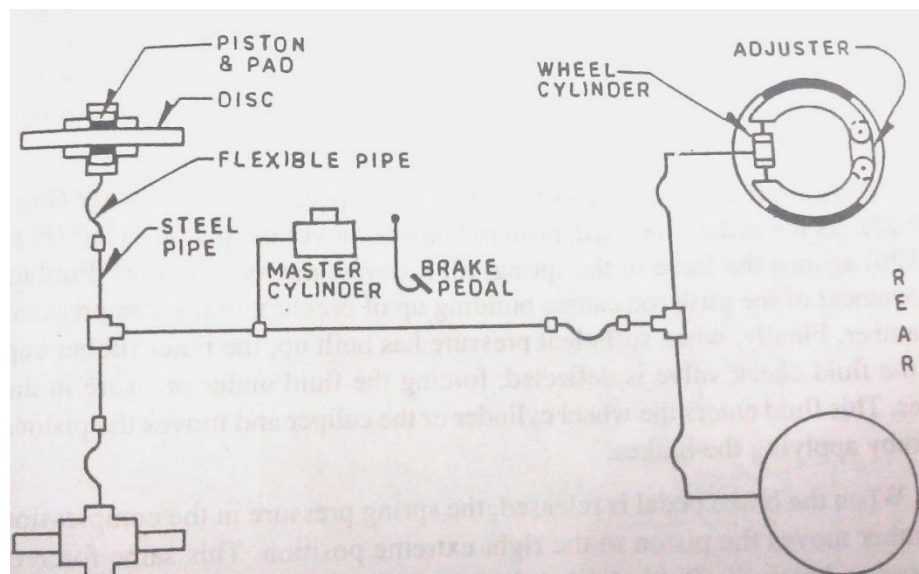

Working :-it consist of master cylinder and wheel cylinder .

Flexible pipes, brake pedal, etc. Pressurised oil from master cylinder flows to wheel cylinder after pressing brake pedal.

Hence brake pressure apply on brake pad.

WINTER – 15 EXAMINATION

Subject Code: 17526 (Automobile Engineering) Model Answer

Q4 A) Attempt any three of the following

a) **Requirements of suspension system :- (any four points 4marks)**

- Minimum deflection consistent with required stability.
- Comparability with other vehicle components. i.e. tyre, frame etc
- Minimum wheel hop.
- Low maintenance and operating cost.
- Low initial cost.
- Minimum weight and tyre wear.

b) **Construction of air suspension with neat sketch :- (sketch 2m construction 2m)**

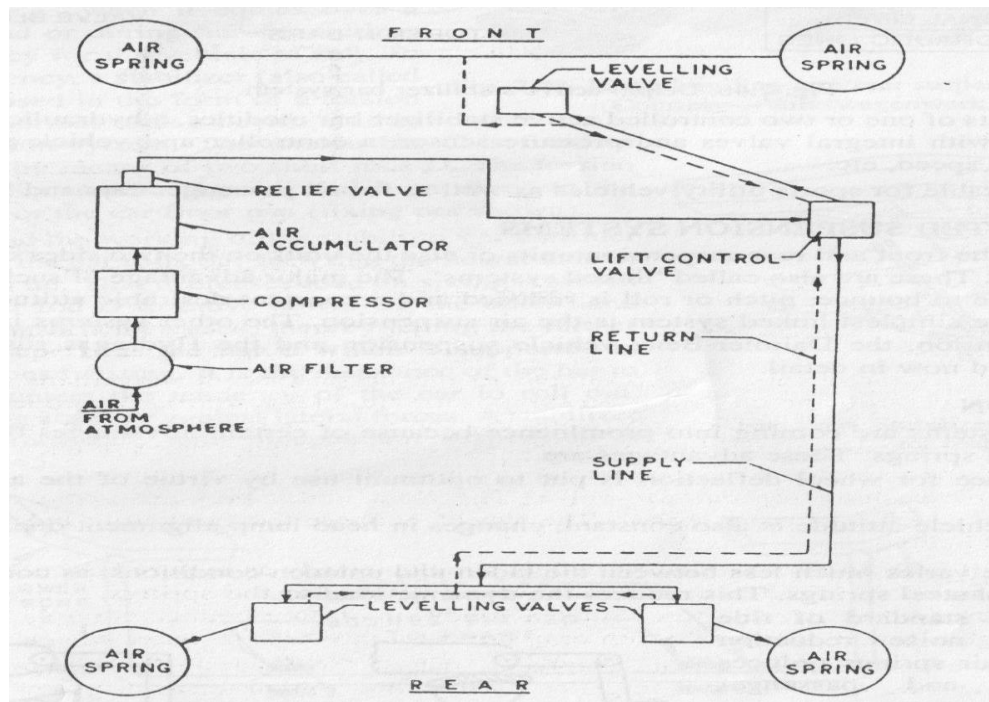

AIR SUSPENSION SYSTEM

Construction :-



WINTER – 15 EXAMINATION

Subject Code: **17526 (Automobile Engineering) Model Answer**

- It consists of four air bags replaced by four springs.
- Air bags are filled with compressed air and mounted on beneath the chassis.
- Air gets further compressed and absorbs the shock when wheel encounter a bump on the road.
- Controls through valve control system
- Type:-1) Air bag type 2) piston type

c) **The various colour codes used for different cables in automobile :-**

S.N.	Colour	Circuit	Example with tracer
1.	Brown	Battery and generator circuit.	Starter switch to control box - brown with blue tracer.
2.	Yellow	Overdrive circuit.	Overdrive switch or column to overdrive relay - yellow with green tracer.
3.	White	Ignition circuit and all other requirements when ignition circuit is switched or without fuse protection.	Starter switch to solenoid switch - white with red tracer.
4.	Green and light green	Auxiliary circuits fed through ignition switch as well as protected by ignition auxiliary fuse.	Stop lamp switch to stop lamp - green with purple tracer.
5.	Purple	Circuits protected by fuse and normally not controlled by the ignition switch.	Horn push to horn - purple with black tracer.
6.	Blue	Head lamp circuit.	Lighting switch to head lamp - blue with white tracer.
7.	Red	Side and tail lamp circuit including fog lamp, panel lights etc.	Penal lamp switch to panel lamp - red with white tracer.
8.	Black	Earth (ground) circuits.	

(any four points 4 marks)

WINTER – 15 EXAMINATION

Subject Code: 17526 (Automobile Engineering) Model Answer

d) **Function of bendix drive in starter system:- (fig=2marks,function =2marks)**

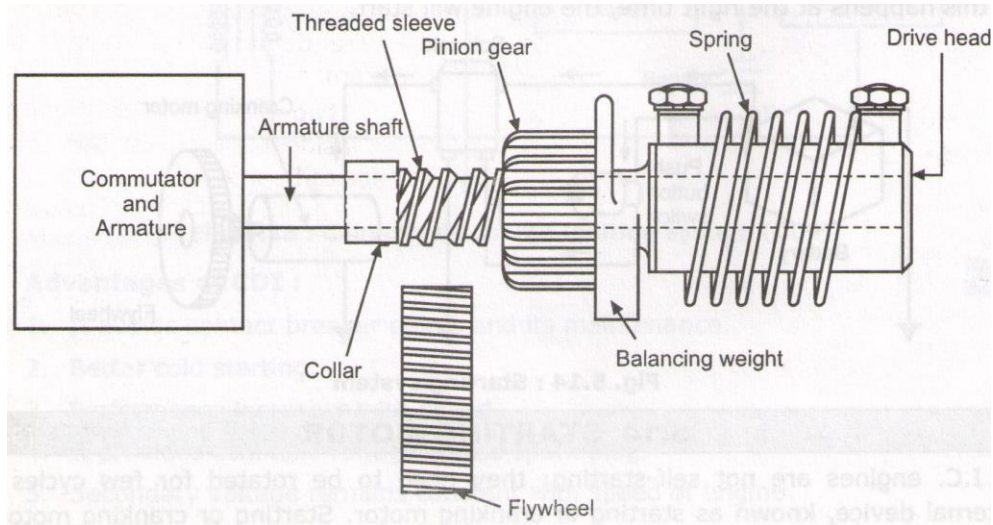

Function:-

- Bendix drive fastened to armature of starter motor armature shaft.
- Armature shaft start revolving at full speed.
- This turning effect is transmitted the head and spring to the threaded sleeve.
- Pinion gear engages flywheel
- Flywheel cranks engine, this shock relived by the spring connection and threaded sleeve.
- This starts the system.

B) Attempt any one of the following (consider relevant points one mark each, any four)

a)Six important precautions for using A/C system in automobile:-

- Donot use A/C with fresh air mode open.
- Never operate a/c with heater on.
- Never run a/c without refrigerant.
- Do not leak test a/c with more than 2 Mpa pressure.
- Donot leave a/c joint open.
- Do not charge refrigerant in a/c system before flushing.



WINTER – 15 EXAMINATION

Subject Code: **17526 (Automobile Engineering) Model Answer**

B) Human comfort parameters:- (min four points=4marks)

Following are the parameters to be considered along with proper elaborations:

- 1) Air Temperature.
- 2) Relative Humidity
- 3) Air velocity
- 4) Mean radiant temp.
- 5) Human activity level and clothing insulation.

Q 5) a)

Any Four advantages of the following (one mark each, min four points)

- 1) It avoids contact breaker points and its maintenance
- 2) Better cold starting
- 3) Performance increases with speed
- 4) It provides constant voltage across spark plug
- 5) Secondary voltage remains constant with speed of engine.
- 6) Eliminate chances of misfiring.

Q 5) b) (types 02 marks ,any one sketch 02 marks)

There are two types of RIMS

- 1) Drop centre rim
- 2) Flat base rim

WINTER – 15 EXAMINATION

Subject Code: 17526 (Automobile Engineering) Model Answer

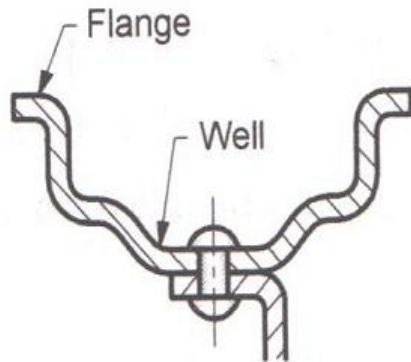

Drop centre rim

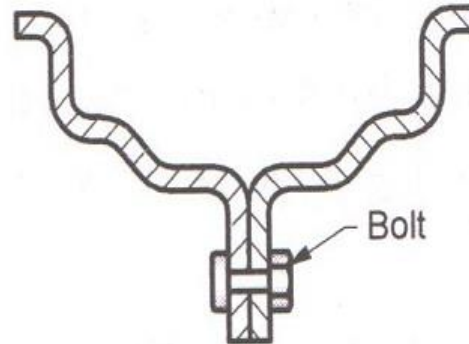

Semi-Drop centre rim

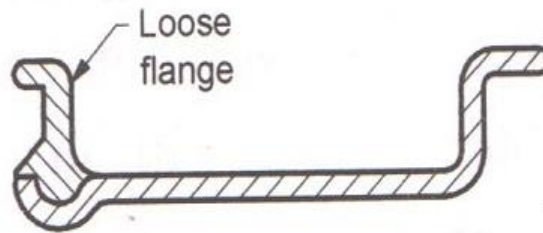

(a) Two piece

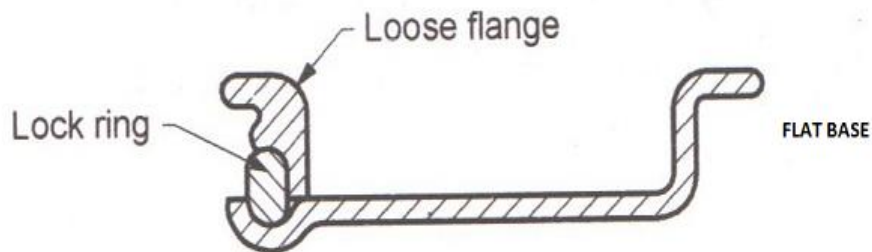

WINTER – 15 EXAMINATION

Subject Code: 17526 (Automobile Engineering) Model Answer

c) Explain with neat sketch Mac-pherson type of Suspension system.

(Description 2 marks)

- **WORKING:-** In this type of Suspension system only lower wishbone is used. A Strut containing shock absorber and the spring carries also the stub axle on which wheel is mounted. The Wishbone is hinged to the cross member .The wishbone positions the wheel as well as resists accelerating, braking and side forces.

(Sketch 2marks)

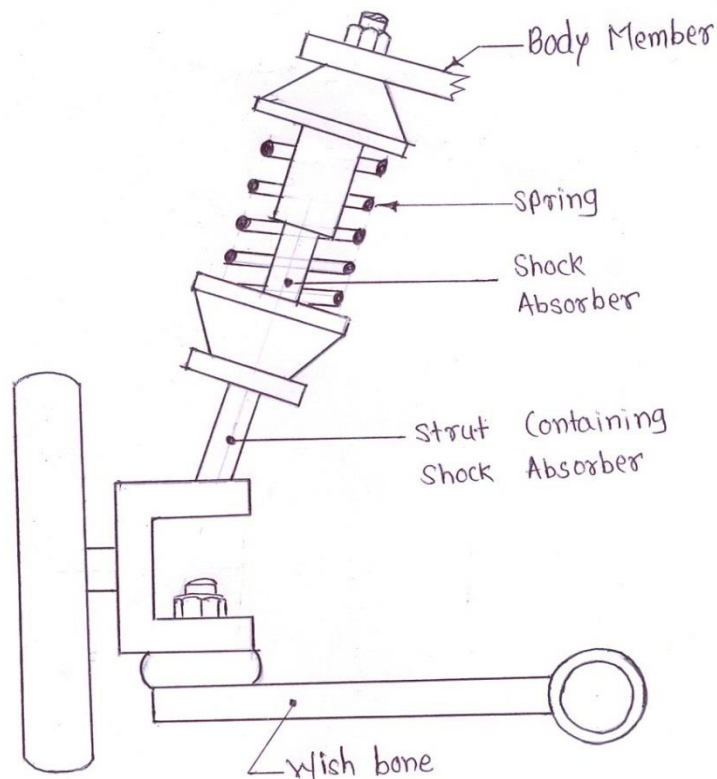

(Mac-Pherson Strut suspension)



WINTER – 15 EXAMINATION

Subject Code: **17526 (Automobile Engineering) Model Answer**

d)Difference between framed and frameless vehicle.(Any four differences one mark each)

Sr.NO.	Framed	Frameless vehicle
1	All mechanical units are attached to perform function of only support(frame)	Performed combine function body and frame.
2	Longitudinal member and cross member form the frame.	Floor is strengthened but cross member and heavy side members are eliminated which are welded together
3	Heavy in weight used for truck and buses	Light in weight used for small cars
4	More fuel consumption	Less fuel consumption
5	Manufacturing cost is more	Manufacturing cost is less
6	Repair is less	Repair is more
7	Frame and body are not integral structure	Frame and body are integral structure For extra strength and durability.

WINTER – 15 EXAMINATION

Subject Code: 17526 (Automobile Engineering) Model Answer

Q 5 e) NOMINECLATURE OF CAR BODY

(line sketch-2m,any four labeling=2m)

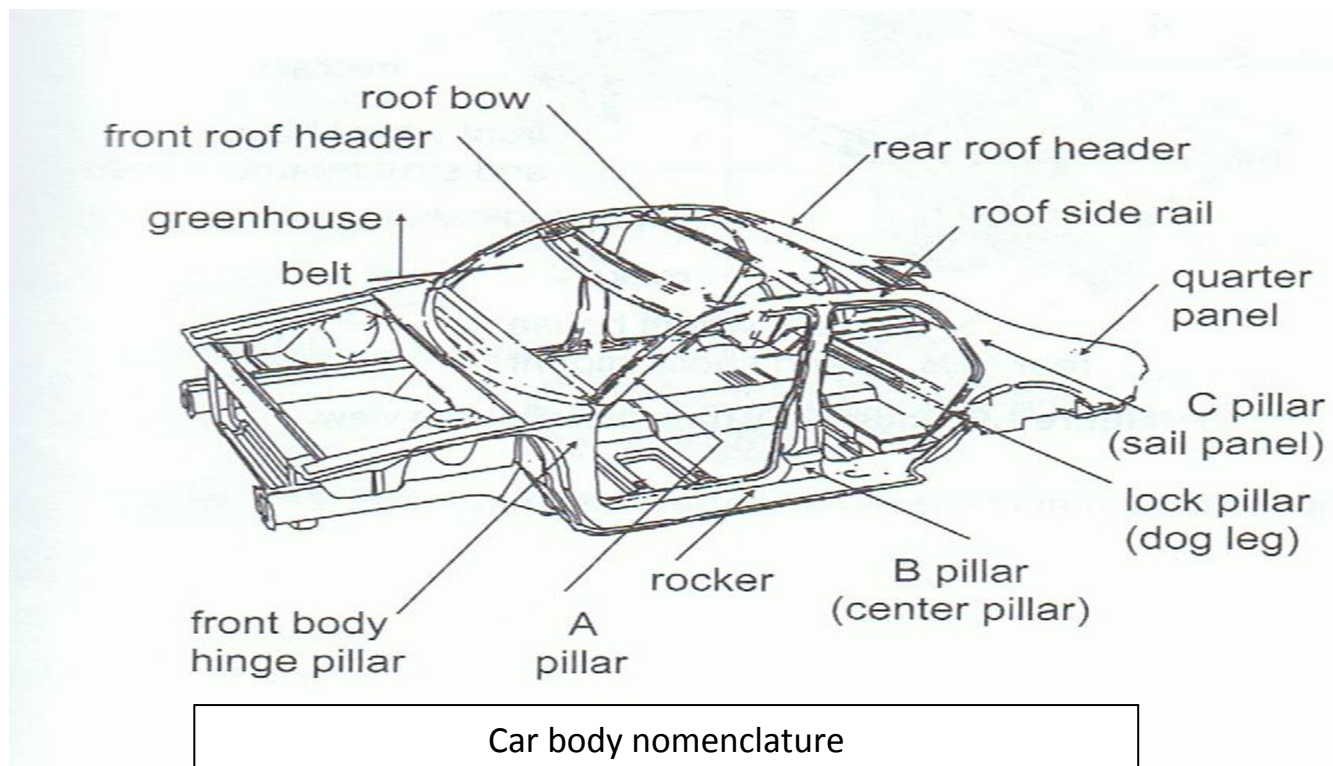

Q.No.6 Attempt any two

a) Different tests of battery (types of test =04 marks,sp gravity test=4marks)

- i) Specific gravity test
- ii) Open circuit voltage test
- iii) light load test
- iv) High discharge test

WINTER – 15 EXAMINATION

Subject Code: **17526 (Automobile Engineering) Model Answer**

v) Cadmium test

Specific gravity test:-

This can be done by the use of Hydrometer contained in a syringe hydrometer consists of a barrel type glass tube and rubber bulb at the top with a graduated scale marked on it. Squeezing the rubber bulb sucks electrolyte into the reservoir. The height of float in a glass sinks in the test. The readings are noted from the scale by sighting along the level of the electrolyte.

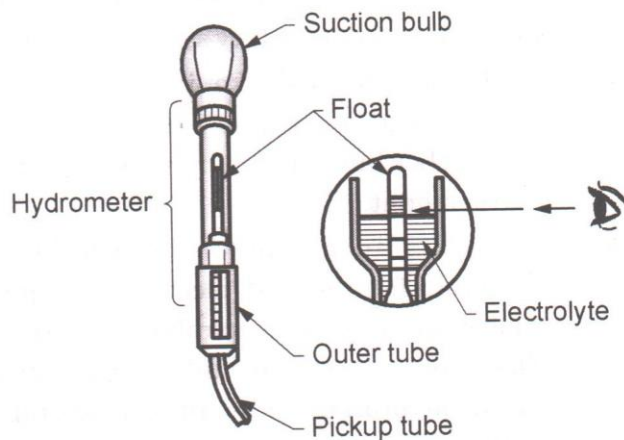

Specific gravity test of battery

WINTER – 15 EXAMINATION

Subject Code: 17526 (Automobile Engineering) Model Answer

b)

i) Fuel Level gauge (04 marks)

A fuel gauge (or gas gauge) is an instrument used to indicate the level of fuel contained in a tank. Commonly used in most motor vehicles, these may also be used for any tank including underground storage tanks.

As used in vehicles, the gauge consists of two parts:

- The sensing unit
- The indicator

The sensing unit usually uses a float connected to a potentiometer, typically printed ink design in a modern automobile. As the tank empties, the float drops and slides a moving contact along the resistor, increasing its resistance. In addition, when the resistance is at a certain point, it will also turn on a "low fuel" light on some vehicles. Most new cars have an arrow on the fuel gauge. It indicates which side the gas tank is on.

Meanwhile, the indicator unit (usually mounted on the dashboard) is measuring and displaying the amount of electric current flowing through the sending unit. When the tank level is high and maximum current is flowing, the needle points to "F" indicating a full tank. When the tank is empty and the least current is flowing, the needle points to "E" indicating an empty tank.

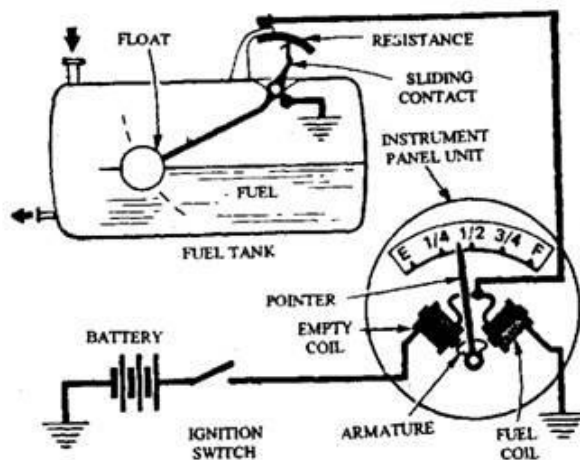

WINTER – 15 EXAMINATION

Subject Code: 17526 (Automobile Engineering) Model Answer

ii) (04 marks)

Lighting system of two wheeler:-

Wiring (Vehicle Lighting System) Circuits for Two Wheeler :

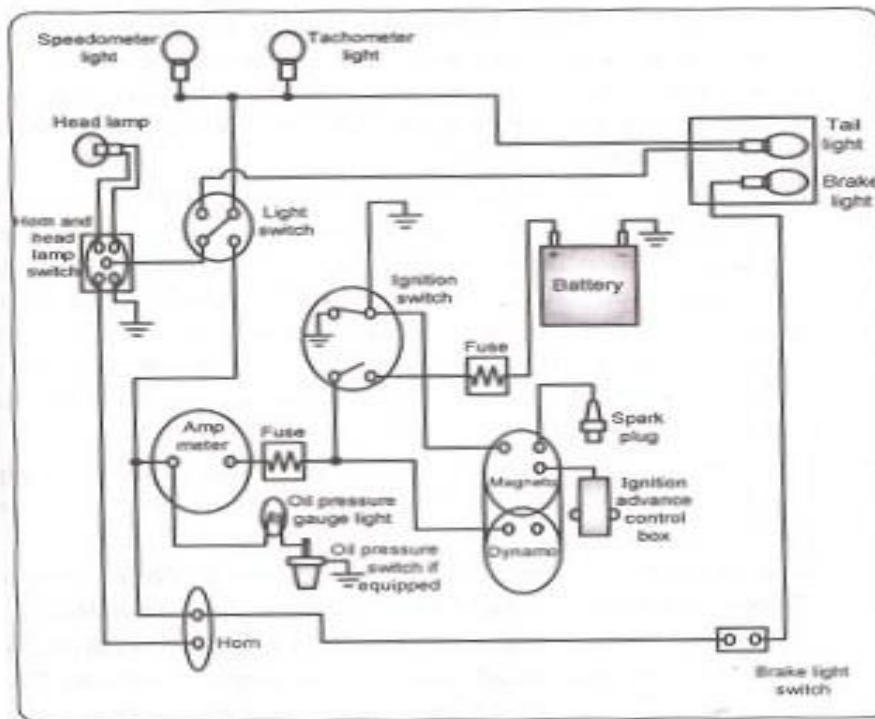

iii) Causes of tyre wear and remedies:- (08 marks, any eight causes)

- 1) Incorrect inflation –ensure correct tyre pressure.
- 2) Excessive braking and violent acceleration ---avoid rash driving
- 3) Worn king pins-----replace it.
- 4) Misalignment -----ensure wheel alignment .
- 5) Wrong loading ----- ensure proper loading



WINTER – 15 EXAMINATION

Subject Code: **17526 (Automobile Engineering) Model Answer**

- 6) Toe-out incorrect on turn----- ensure wheel alignment
- 7) Careless driving --- ensure proper driving
- 8) Incorrect caster ,camber or toe in -----ensure wheel alignment
- 9) Damaged beads--- ensure proper driving
- 10) Bleeding of air in tyre-----ensure valve
- 11) Out of balance wheel----- ensure wheel alignment