

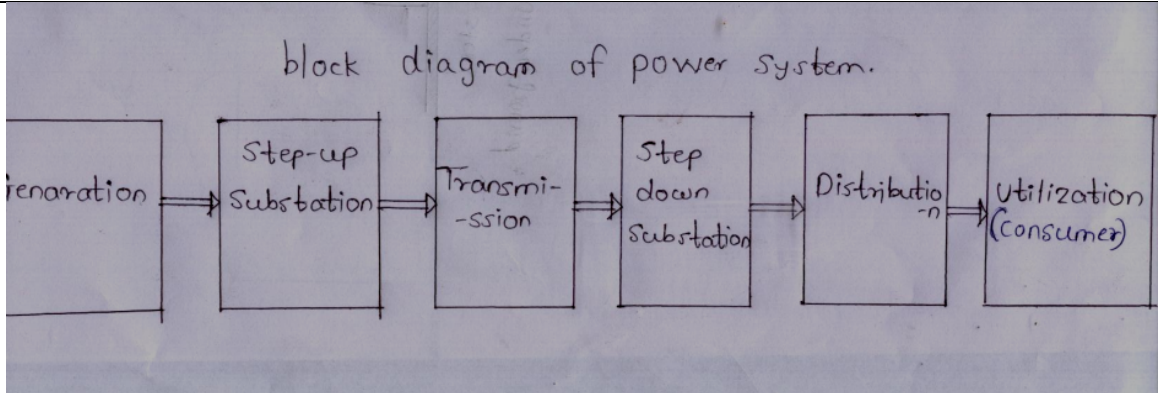

Important suggestions to examiners:

- 1) The answers should be examined by key words and not as word-to-word as given in the model answer scheme.
- 2) The model answer and the answer written by candidate may vary but the examiner may try to assess the understanding level of the candidate.
- 3) The language errors such as grammatical, spelling errors should not be given more importance. (Not applicable for subject English and communication skills)
- 4) While assessing figures, examiner may give credit for principle components indicated in a figure. The figures drawn by candidate and model answer may vary. The examiner may give credit for any equivalent figure drawn.
- 5) Credits may be given step wise for numerical problems. In some cases, the assumed constant values may vary and there may be some difference in the candidate's answers and model answer.
- 6) In case some questions credit may be given by judgment on part of examiner of relevant answer based on candidate understands.
- 7) For programming language papers, credit may be given to any other program based on equivalent concept.

Q.1 a)	Attempt any THREE of the following	12 Marks
i)	Draw a block diagram of power system. State the function of each block.	
Ans:	Block diagram of power system (Block Diagram: 2 Mark & Function: 2 Mark)	
<p>Layout of generating plant</p> <p>OR</p>		



Function of each block :

➤ **Generating Voltage:**

It is the voltage actually generated by alternator its voltage magnitude is less as compare to transmission.

➤ **Primary Transmission:**

It is a 3-phase, 3-wire transmission line connected in between substation at generating station and transmission substation or receiving substation e.g. Primary Transmission voltage: - 220 KV, 400KV, 765 KV

➤ **Secondary Transmission:**

It is a 3-phase, 3-wire transmission line connected in between transmission substation to sub transmission substation or receiving substation. e.g. Secondary Transmission voltage :- 220 KV, 132 KV, 110 KV

➤ **Primary Distribution:**

It is a 3-phase, 3-wire transmission line connected in between receiving substation to Distribution substation. e.g. primary distribution voltage 33 KV, 22KV, 11 KV for long distance line it may be 66 KV

➤ **Secondary Distribution:**

It is a 3-phase, 4-wire Distribution line in between Distribution substation to consumer line. e.g. secondary distribution voltage 3-phase, 400 Volt, for single phase 230 Volt



ii)	State the meaning of ACSR conductors. State its advantages.
Ans:	<p>ACSR conductor:- (1 Mark)</p> <p>Aluminum strands (conductor / wires) surrounded a core of one or more steel wires. The diameter of aluminum & steel wires are same</p> <p>➤ Advantages of ACSR Conductors: (Any Three Advantages Expected: 1 Mark each)</p> <ol style="list-style-type: none">1. Due to steel re-inforcement, mechanical strength of conductor increases2. As the mechanical strength is more ACSR conductors produces small Sag.3. It takes advantages of Skin effect. So skin effect is minimized.4. Corona Loss reduces.5. It is 50% stronger & 20% Lighter than copper.6. It is cheaper than copper.
iii)	Describe skin effect.
Ans:	<p style="text-align: right;">(Figure: 2 Mark & Explanation: : 2 Mark)</p> <div data-bbox="487 1155 1380 1512" data-label="Diagram"></div> <p>Explanation:</p> <p>When alternating current flows through conductor it has tendency to flow away from center of conductor.</p> <p>i.e. maximum current density is near skin of conductor and goes on reducing towards centre core is known as skin effect. OR</p> <p>The tendency of alternating current to concentrate near the surface of a conductor is known as skin effect.</p>



iv)	State the necessity and importance of EHV transmission.
Ans:	<p style="text-align: center;">(Any Two point of necessity are expected: 1 Mark each)</p> <p>Because of following points there <u>is necessity</u> of transmission of power:</p> <ul style="list-style-type: none">a) Electrical load on power system is not concentrated at one place but it is widely spread.b) Load points are located away from generating station.c) Due to limitation of site selection criteria of major generating Station (HPP, TPP & NPP) are located far away from load centers and hence the electricity need to transmit from generating stations to the point of actual utilization of it (consumers) for this purpose transmission electricity is necessary. <p><u>Important of EHVAC Transmission:-</u></p> <p style="text-align: center;">(Any Two point of important are expected: 1 Mark each)</p> <p style="text-align: center;">We know that, $P = \sqrt{3} V_L I_L \cos \phi$</p> <p>For,</p> <ul style="list-style-type: none">• Same power to be transferred• At same power factor• At same transmission line distance <p style="text-align: center;">$I \propto \frac{1}{V}$ from This Equation It is clear that due to High Transmission Voltage</p> <p>Following are the advantages Hence EHVAC Transmission is adopted:</p> <p>Advantages:</p> <ol style="list-style-type: none">1. As Transmission voltage increases, current decreases. (as $I \propto \frac{1}{V}$)2. As current decreases, cross section of conductor decreases. [as c/s of conductor $\propto I$]3. As cross section of conductor decreases, its weight decreases.4. As weight of the conductor decreases, design of tower becomes lighter in weight.5. As current decreases, cross section of bus bar and size of switch gear contact etc. reduces.6. Due to above advantages, Transmission cost per KM decreases7. As transmission voltage increases. A current decreases, so copper losses in transmission line reduces.(as $Cu.Losses \propto I^2$)



8. As copper losses reduces, transmission efficiency increases [as Tr. $\eta_T \propto \frac{1}{Cu.loss}$]
9. As current reduces, voltage drop in transmission line reduces. [as Voltage drop $\propto I \propto \frac{1}{V}$]
10. As voltage drop in transmission reduces, voltage regulation becomes better (improved).
11. As efficiency and regulation of transmission line gets improved, so performance of transmission line increases
12. As transmission voltage increases power handling capacity of transmission line increases (as $P \propto V^2$)
13. Due to high voltage transmission line, successful interconnection of transmission line is possible than low voltage.
14. Generating Stations are generally located away from load centre.
- Hence, EHVAC transmission line becomes necessary for bulk power to be transmitted over a long distance**

Q.1 b) Attempt any ONE of the following: 06 Marks

i) Compare copper and Aluminium on any six points.

Ans:

(Any Six point are expected: 1 Mark each)

S. No	Points	Copper	Aluminum
1	Conductivity	High (1.6 times more than Aluminum)	Less than copper (1.6 times lesser than copper)
2	Resistivity	Less than aluminum $\rho = 1.68 \times 10^{-8}$ ohm m / 0.01786 ohm m /mm ² at 20 ⁰ C	More than copper $\rho = 2.8 \times 10^{-8}$ ohm m / 0.0287 ohm m/mm ² at 20 ⁰ C
3	Cross section of conductor	For same current cross section of copper conductor is less than aluminum conductor by 60%	For same current cross section of aluminum conductor is 60% more than copper conductor.
4	Mechanical Strength	High, twice that of aluminum. Tensile strength = 40 kg/mm ²	Less, half that of copper. Tensile strength = 18 kg/mm ²
5	Weight	High, it is three times heavier than aluminum. specific gravity = 8900	Low, it is three times lighter than copper. specific gravity = 2700 kg/mm ²



MAHARASHTRA STATE BOARD OF TECHNICAL EDUCATION
(Autonomous)
(ISO/IEC-27001-2005 Certified)

SUMMER– 2015 Examinations

Subject Code: 17417

Model Answer

Page 6 of 32

			kg/mm ²	
6	Flexibility	Less flexibility than aluminum		More flexibility than copper
7	Temperature coefficient of resistance	$\alpha = 0.0038/^{\circ}\text{C}$ at 20 ⁰ C		$\alpha = 0.004/^{\circ}\text{C}$ at 20 ⁰ C
8	Current density	High		Less
9	Soldering & Welding	It can be welded & solder		Pure aluminum can't be welded or soldered
10	Melting point	1083 ⁰ C		655/658 ⁰ C
11	Thermal conductivity	Thermal conductivity of copper is about twice that of aluminum		Thermal conductivity of aluminum is about twice times less that of copper
11	Colour	Radish brown		Silver white
12	Cost	High		Less than copper
13	Scrap value	High		Less than copper
14	Recyclability	Copper is 100 % recyclable without loss of properties		Aluminum is 100 % recyclable without loss of properties
15	Young modulus	13000 kg/mm ²		5600 kg/mm ²

ii) **A 11 kV, 3 - Phase transmission line has a resistance of 1.5 ohm and reactance of 4 ohm/phase. Calculate the percentage regulation and efficiency of the line when total load of 5000 kVA at 0.8 p.f. lagging is supplied at 11 kV at the distance end.**

Ans: **Given Data:-** **(Each Step : 1 Mark each)**

$P_R = 5000\text{KVA}$ $V_R = 11\text{KV}$ $\text{P.F.} = 0.8 \text{ lag}$ $R_{ph} = 1.5 \text{ ohm}$ $X_{ph} = 4 \text{ ohm}$

<p>Step 1: To calculate current:</p> <p style="text-align: center;">Power in KW=KVA × P.F. Power in KW=5000 × 0.8 Power in KW= 4000 Kw</p> <p style="text-align: center;">Power P = $\sqrt{3} V_L I_L \cos \phi$ for 3 – ph</p> $I \equiv \frac{P}{\sqrt{3} V_{LR} \times \cos \phi}, \quad I \equiv \frac{4000}{\sqrt{3} \times 11 \times 0.8}$ <p style="text-align: center;">$I \equiv 262.43194 \text{ amp}$</p>	<p>Step 2: To calculate value of sin :</p> <p style="text-align: center;">$\therefore \cos \phi_R = 0.8; \quad \sin \phi_R = 0.6$</p> $V_{Rph} \equiv \frac{V_{RL}}{\sqrt{3}}$ $V_{Rph} \equiv \frac{11}{\sqrt{3}}$ <p style="text-align: center;">$V_{Rph} \equiv 6.3508 \text{ KV or } V_{Rph} = 6.3508 \times 10^3 \text{ V}$</p>
---	---



	<p>Step 3: To calculate Sending end voltage:</p> <p>Sending end phase voltage (V_{sph})=</p> $= V_{Rph} + I (R_{ph} \cos \phi_R + X_{ph} \sin \phi_R)$ $= 6.3508 \times 10^3 + 262.43194 (1.5 \times 0.8 + 4 \times 0.6)$ $= 7295.554984 \text{ V}$ $= 7.29555 \text{ KV}$ <p>Sending End Line Voltage =</p> $\therefore V_{SL} = \sqrt{3} \times V_{sph}$ $V_{SL} = \sqrt{3} \times 7.29555$ $= 12.6359 \text{ KV}$	<p>Step 4: To calculate voltage regulation:</p> $\% \text{ Voltage Regulation} = \frac{V_{Sph} - V_{Rph}}{V_{Rph}} \times 100$ $= \frac{12.6359 - 11}{11} \times 100$ $= 14.87 \%$	
	<p>Step 5: To calculate Total Line Losses:</p> $\text{Total Line Losses} = 3 I^2 R_{ph}$ $= 3 (262.43194)^2 \times 1.5$ $= 309917.35 \text{ Watt}$ $= 309.91735 \text{ KW}$	<p>Step 6: To calculate Total Transmission efficiency:</p> $\% \eta_T = \frac{P_R}{P_R + 3I^2 R_{ph}} \times 100$ $\% \eta_T = \frac{4000 \times 10^3}{4000 \times 10^3 + 309.91735 \times 10^3} \times 100$ $\% \eta_T = 92.8092\%$	
Q.2	Attempt any FOUR of the following :		
	16 Marks		
a)	Give the comparison between primary transmission and secondary transmission system.		
Ans:	(Any Four point are expected: 1 Mark each)		
	Sr.No.	Primary transmission system.	Secondary transmission system.
	1	It is link between Generating substation & Primary sub station	It is link between Primary substation & receiving substation
	2	Voltage is 220KV/400KV/765KV	Voltage is 220KV /110KV/132KV
	3	Conductors are high capacity conductors than Secondary transmission system.	Conductor's high capacity conductors.
	4	Height of Tower is more than secondary transmission system.	Height of Tower is less than primary transmission system.
	5	Its loading point is at Generating substation only.	Its loading point is at Primary substation only.



b) Compare overhead line and underground cable.

Ans:

(Any Four point are expected: 1 Mark each)

S.No	Points	Overhead line	Underground cable
1	Capital cost	Less	More
2	Erecting cost	Less	More
3	Time require for completion of work	Less	More
4	Flexibility	More flexibility	No flexibility
5	Future expansion in voltage level	System voltage can be increased easily	System voltage cannot be increased
6	Overload capacity	More	Less
7	Fault finding	Easy	Difficult
8	Charging Current	Less	More
9	Chances of fault	More	Less
10	Chances of accident	More	No chances of accident
11	Safety	Less	More
12	Radio interference	Produces radio interferences	Not produces radio interferences
13	Short cute route	Difficult	possible
14	Theft Of energy	More possibility	Less possibility
15	Voltage drop	More	less
16	Power factor	Less	More
17	Reliability	Less	More
18	Life	Less	More
19	Space consumed	Space consumed	No space consumed
20	Appearance	Not good	Very good

c) Describe the Ferranti effect with the help of neat phasor diagram.

Ans:

Ferranti effect with the help of neat phasor diagram

Suppose transmission line is subjected to following Conditions:

(2Mark)

- When there is no load on transmission line ($I_L = 0$) Or
- When There is no load at receiving sub-station or Lightly loaded Or
- When there is sudden load thrown OFF. Or
- When there is sudden load shading. Or



➤ When Transmission line is open circuited due to load failure.

Under any one of the above mention conditions, it is found that receiving end voltage (V_R) is found to be greater than sending end voltage (V_S). This phenomenon is known as Ferranti effect.

Phasor Diagram:

(2Mark)

Load Current (I_R) is negligible as compare to charging current (I_c)

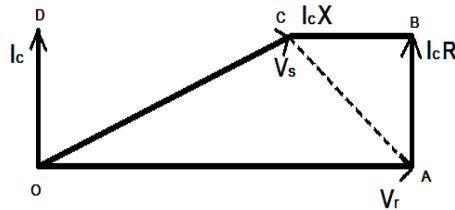

Ferranti effect in transmission lines.

d) Define efficiency and regulation of transmission line.

Ans:

1. Transmission efficiency:-

(2 Mark)

$$\text{Transmission Efficiency} = \frac{\text{Output power at receiving end}}{\text{Input power at sending end}} \times 100 \quad \text{OR}$$

$$\eta_T \% = \frac{\text{Output } (P_R) \text{ (Load (power) at reciving end)}}{\text{Output } (P_R) + \text{Total losses}} \times 100$$

2. Regulation:

(2 Mark)

Voltage regulation is nothing but voltage drop in transmission line expressed in % of receiving end voltage

$$\% \text{ Regulation} = \frac{\text{Sending End Voltage} - \text{Receiving End Voltage}}{\text{Receiving End Voltage}} \times 100$$



e) Draw a block diagram of HVDC transmission. State the function of each block.

Ans:

(Block Diagram : 2 Mark & Function : 2 Mark)

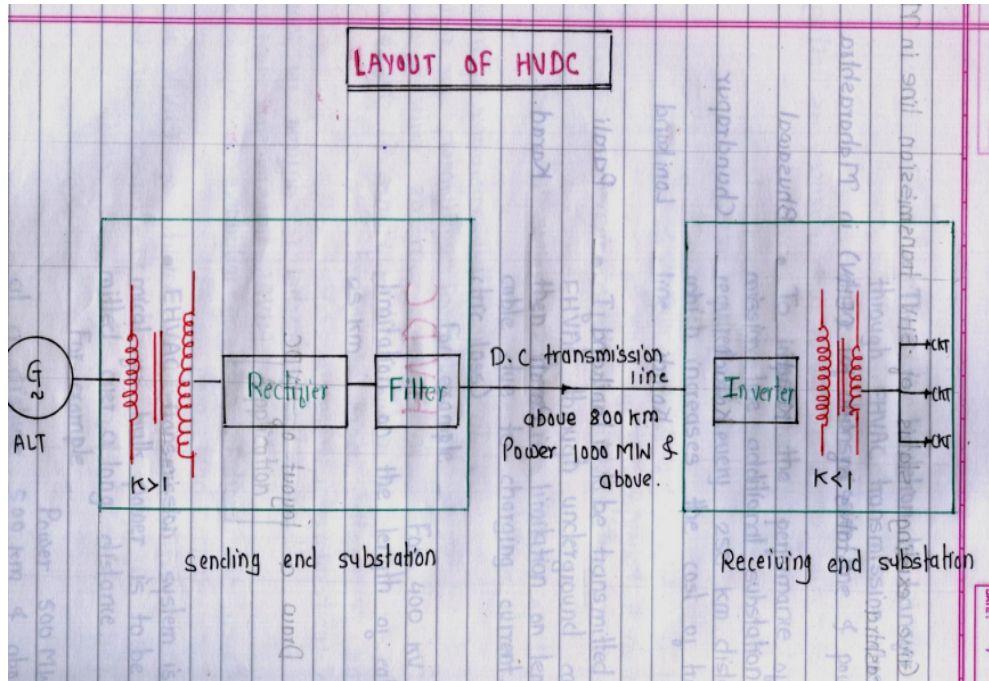

OR

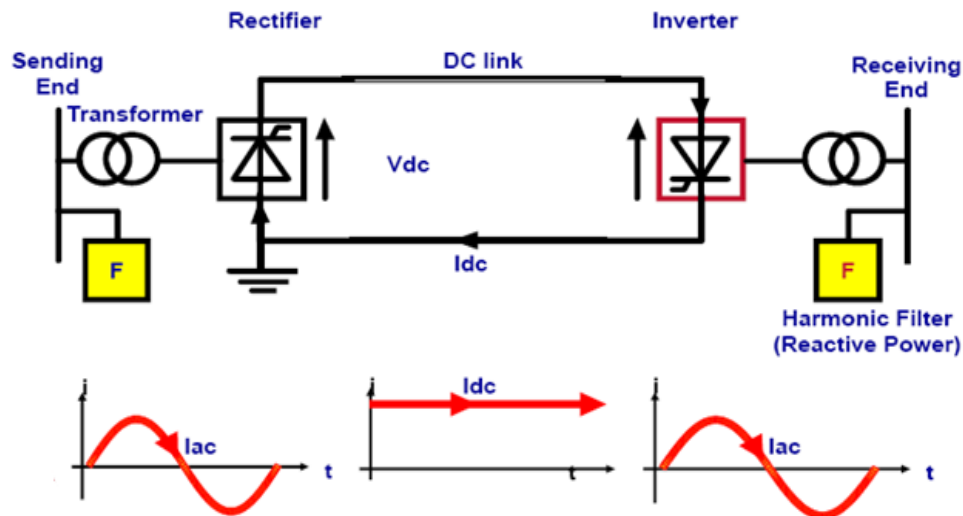

Function :-

- 1) Sending voltage is rectified and converted to D.C. with the help of Rectifier.
- 2) Transmission of D.C. voltage
- 3) At receiving end D.C. voltage is again converted in to A.C. with the help of Inverter



Q.3 Attempt any Two of the following : **16 Marks**

a) Describe the construction of cable with well labelled diagram.

Ans:

(Diagram : 2 Mark & Construction of each layer : 1 Mark each)

Constructional Diagram of Cable :-

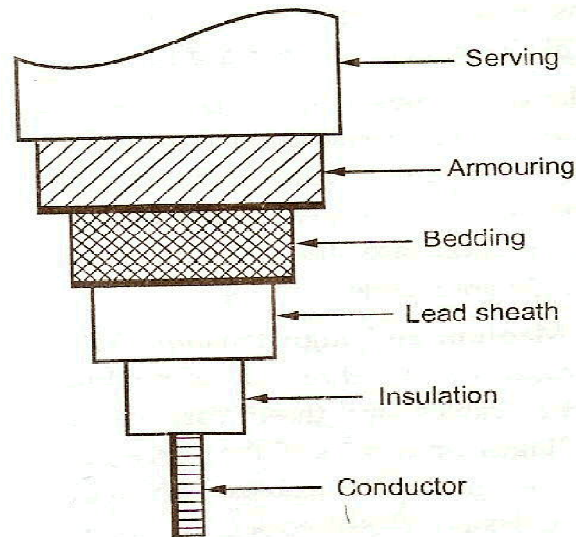
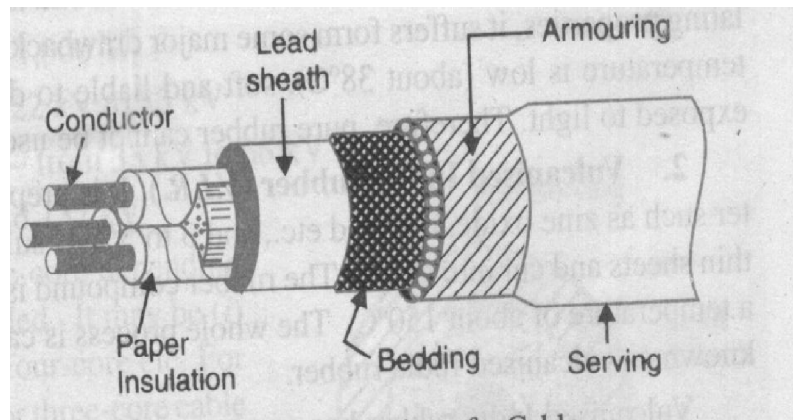

Fig. 3.1 General construction of a cable

OR



1) Core or conductor :

- Its function is to carry current. Cross section of conductor is directly proportional to current.
- Cable may have 1 or more than 1 core conductor.



2) Insulation:

- Each core of conductor is provided with suitable thickness of insulation to avoid short circuit between two conductors.

3) Metallic (Lead) Sheath:

- It is provided over insulation to provide the protection of core from entry of moisture, gases or other damaging liquids (acids & alkaline) in the soil & atmospheric,
- The metallic sheath is of lead or lead alloys is provided on the insulation *recently aluminum is also being used as a metallic sheath*

4) Bedding:

- Over the metallic sheath there is layer of bedding.
- The purpose of bedding is protecting the metallic sheath against corrosion & from the mechanical injury due to armouring.
- It is made from fibrous material such as jute, hessian tape

5) Armouring:

- This layer is over a bedding only underground cable and not for over head cable
- It covers the bedding, which consists of 1 or 2 layers of galvanized steel wire or steel tapes.
- Its purpose is to protect the cable from mechanical injury, while rough handling & at the time of maintenance.

6) Serving:

- This layer is last layer which comes over armouring.
- Its function is to protect armouring or to cover armouring against rusting and it also helps for easy handling of cables.
- It is similar to bedding & consists of fibrous material such as jute



b) (i) Compare Nominal - T and Nominal - π method of medium transmission line.

Ans:

(Any Four Point Expected : 1 Mark each)

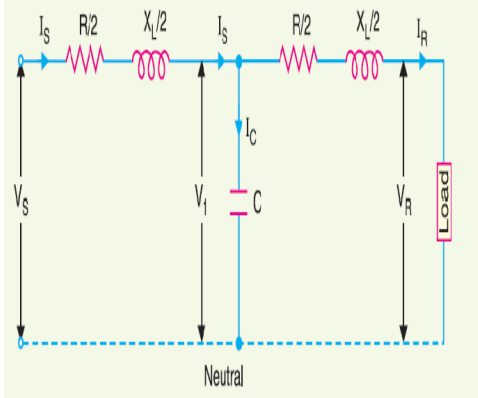
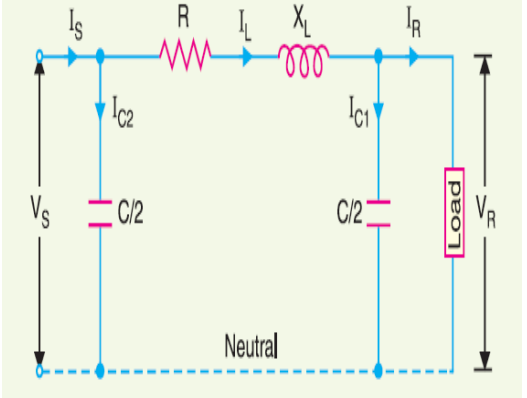
Sr.N o	Nominal T Method	Nominal π Method
1	It is assume that line capacitance is connected at centre of transmission line	It is assumed that capacitance of transmission line is divided into half of the line capacitance is connected at receiving end & half of capacitance is connected at sending end.
2	It is assume that half of the resistance & reactance per phase are divided in either side of capacitance.	It is assumed that transmission line resistance & reactance per phase is connected in between two half transmission line capacitance
3	Shape of equivalent circuit is like letter 'T' hence its name is nominal 'T' method	Shape of equivalent circuit is like letter ' π ' hence its name is nominal ' π ' method
4		
5	Values of ABCD constants T-equivalent circuits of are as bellows: $\therefore A = D = 1 + \frac{YZ}{2}$ $\therefore B = Z \left[1 + \frac{YZ}{4} \right] \text{ ohm}$ $\therefore C = Y \text{ mho}$	Values of ABCD constants π equivalent circuits of are as bellows: $\therefore A = D = 1 + \frac{YZ}{2}$ $\therefore B = Z \text{ ohm}$ $\therefore C = Y \left[1 + \frac{YZ}{4} \right] \text{ mho}$



<p>b)</p> <p>Ans:</p>	<p>(ii) State the effect of load power factor on performance of transmission line.</p> <p>1. Effect of improved power factor on Efficiency:- (2 Mark) As power factor increases, current decreases, so Copper losses decreases, Hence transmission efficiency increases & vice versa.</p> <p>2. Effect of improved power factor on Regulation:- (2 Mark) As power factor increases, current decreases, So Voltage drop in transmission line decreases, As a result, regulation get improved (decrease) an vice versa.</p> <p style="text-align: center;">OR</p> <p>1. Effect of poor power factor on efficiency:- (2 Mark)</p> <p>➤ When power factor of load reduces current drawn by transmission line increases so copper losses in transmission line increases, hence transmission efficiency reduces.</p> <p>2. Effect of poor power factor on voltage Regulation:- (2 Mark)</p> <p>➤ When power factor of load reduces current through transmission line increases, so voltage drop in transmission line (due to resistance & inductive reactance) increases so regulation increases. (Become Poor)</p>
<p>c)</p> <p>Ans:</p>	<p>(i) State the requirements of an ideal distribution system.</p> <p style="text-align: right;">(Any Four Point of requirement Expected : 1 Mark each)</p> <p>Ideal distribution system should posses following requirements:</p> <ol style="list-style-type: none">1) Design of Layout: layout should be simple in design.2) Time required for completion: Time required for completion of work should be less.3) Initial Cost: It should be less.4) Maintenance: It should be low, easy, less costly & less time consuming.5) Reliability: It should have high reliability.6) Voltage fluctuation: It should be less and within permissible limit.7) Availability of power: - It should be available whenever needed (Power must be available to all consumers on demand that they may require from time to time.)8) Stability: Fault on nearest distribution system should not affect stability of existing distribution system.



c)	ii) State the controlling factors in determining the size of a distributor.
Ans:	<p style="text-align: right;">(Each Point : 1 Mark)</p> <p>Following are the controlling factors in determining the size of a distributor</p> <ol style="list-style-type: none">1) Voltage drop limit: It should be within permissible limit ($\pm 6\%$)2) Length of distributor: There is limit to length of distributor due to voltage drop permissible limit.3) Size (cross-section) of conductor: - Cross section of conductor should be of sufficient current carrying capacity.4) Availability of power: - Power should be available whenever needed (Power must be available to all consumers on demand that they may require from time to time.)
Q.4 a)	Attempt any THREE of the following : 12 Marks
i)	Give the classification of transmission line according to: 1) Voltage level 2) Length of Transmission Line 3) Types of supply voltage and 4) Method of construction
Ans:	<p>1) According to Voltage level: (1 Mark)</p> <ol style="list-style-type: none">a) High voltage Transmission Line (HV) up to 33 KVb) Extra High Voltage Transmission Line (EHV) up to 400 KVc) Ultra High voltage Transmission Line (UHV) above 400 KV <p>2) According to Length of Transmission line: (1 Mark)</p> <ol style="list-style-type: none">a) Short Distance Transmission Line - (up to 50 KM)b) Medium Distance Transmission Line - (up to 50 to 150 KM)c) Long Distance Transmission Line - (above 150 KM) <p style="text-align: center;">OR</p> <ol style="list-style-type: none">1) Short Transmission Line: - The length of Short transmission Line is up to 50KM and its line voltage is less than 20 KV2) Medium Transmission Line: - The length of Medium transmission Line is up to 50KM- 150KM and its line voltage is between 20KV to 100 KV



3) Long Transmission Line: - The length of Long transmission Line is above **150KM** and its line voltage is above **100KV**

OR

1) Short Transmission Line: - The length of Short transmission Line is up to **80KM** and its line voltage is **less than 20 KV**

2) Medium Transmission Line: - The length of Medium transmission Line is up to **80KM- 200KM** and its line voltage is between **20KV to 100 KV**

3) Long Transmission Line: - The length of Long transmission Line is above **200KM** and its line voltage is above **100KV**

3) According to type of supply:

(1 Mark)

- a) A.C. Supply Transmission Line system
- b) D.C. Supply Transmission Line system

4) According to Method of Construction:

(1 Mark)

- a) Overhead transmission line system
- b) Underground transmission line system.

ii) **Draw the short transmission line representation and its vector diagram and write the expression for V_s from the phasor diagram. Also write the expression for percentage voltage regulation and transmission efficiency.**

Ans: **Short transmission line representation:**

(1 Mark)

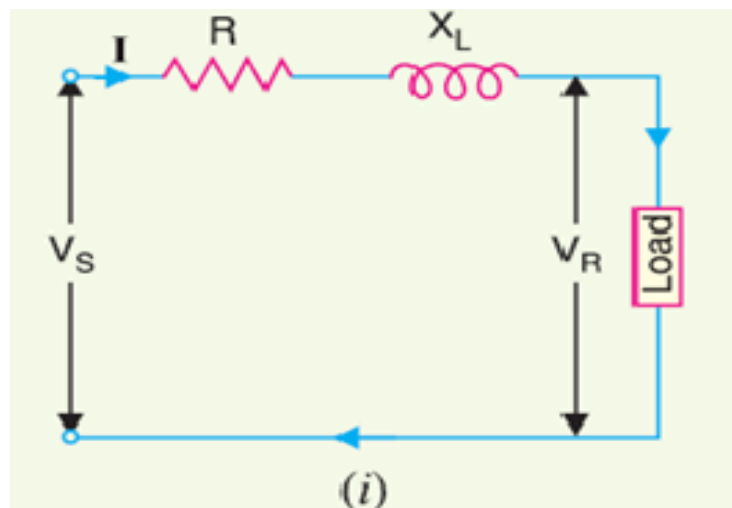



Vector Diagram:

(1 Mark)

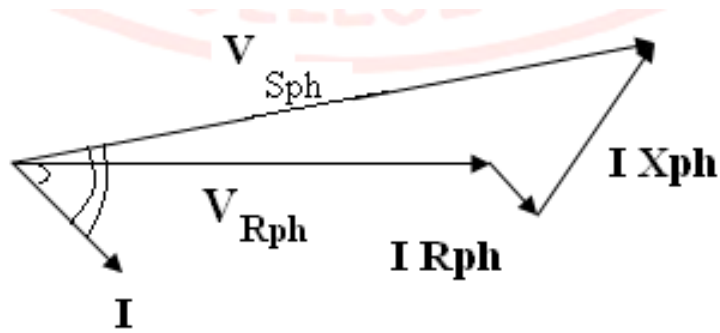

Expression for percentage voltage regulation:

(1 Mark)

$$V_s \cong V_R + I(R_T \cos\phi_R \pm X_T \sin\phi_R)$$

$$\% \text{ age Voltage Regulation} = \frac{V_s - V_R}{V_R} \times 100$$

Expression for Transmission efficiency:-

(1 Mark)

$$\text{Transmission Efficiency} = \frac{\text{Output}}{\text{Input}}$$

$$\eta_T \% = \frac{\text{Output } (P_R) \text{ (Load (power) at reciving end)}}{\text{Output } (P_R) + \text{Total losses}} \times 100$$

OR

$$\% \text{ Efficiency} = \frac{\text{output power}}{\text{output power} + \text{total copper losses}} \times 100$$

iii) Compare EHVAC and HVDC transmission line.

Ans:

(Any Four Point Expected : 1 Mark each)

Sr.No	Points	EHVA.C	HVDC
1	Number of conductor required for single circuit	Three conductors (R.Y.B)	One conductor.& Ground is used as a return path
2	For double circuit	Six conductors (R,Y,B & R,Y,B)	Two conductors.& Ground is used as a return path
3	Design of Tower	Heavy	Light
4	Intermediate substation	Required at very 250 Km	Not required



MAHARASHTRA STATE BOARD OF TECHNICAL EDUCATION
(Autonomous)
(ISO/IEC-27001-2005 Certified)

SUMMER– 2015 Examinations

Subject Code: 17417

Model Answer

Page 18 of 32

5	Capital cost of S/S	Less	More
6	Transmission line cost/km	More	Less
7	Ground return	Not possible	Possible
8	Frequency	Present	Absent
9	Skin effect	Present	Absent
10	Proximity effect	Present	Absent
11	Ferranti effect	Present	Absent
12	Corona losses	More	Less
13	Radio interference	Present	Absent
14	Effect of L & C	Present	Absent
15	Value of resistance	More 1.6 times than DC	Less
16	Copper loss	More	Less
17	Transmission Efficiency	Less	More
18	Voltage drop in transmission line	More	Less
19	% Regulation	Good	Better
20	Limitation on length of cable	Due to charging current there is limitation on length of cable	Charging current is absent so no limitation on length of cable
21	String efficiency	Less than 100 %	100 %
22	Losses in S/s	Less	More
23	Maintenance cost of S/S	Less	More
24	Asynchronous tie	Not possible	Possible
25	Reliability & availability	Two AC circuit are necessary	One bipolar line is sufficient
26	Control system	Simpler cheaper	Difficult, costly
27	Power handling capacity	There is limit due to power angle & inductance	No limit
28	Voltage control	Difficult for long distance lines due to presence of L & C	Easier as L&C are not effective
29	Stability limit	EHVAC limits due to power angle & inductance	No limit due to absent of power angle & inductance
30	Power flow control	Power flow cannot be easily controlled, (slow)	Power can be quickly(fast) controlled,
31	Power transfer ability	Lower	High
32	Transient performance	Poor	Excellent
33	Back to Back conversion stations	Not Possible	Possible
34	Short ckt current level	More	Less
35	Reliable circuit	Available	Not available



		breaker		
	36	Fault levels	Get added after interconnection	Remains unchanged
	37	Frequency conversion	Not possible	Possible
	38	Cascade tripping of circuit	Likely	Avoided
	39	Spinning reserve	Not much reduced	Reduced
	40	Frequency of fault	More	Less
iv)	State the components of distribution system.			
Ans:	Following are the different components of distribution system:- (Each Components : 1 Mark) 1. Feeder (Primary distribution): It is 3-Ph Three-Wire System and voltage level is 11/22/33 KV depending upon load 2. Distribution Transformer (DTC): It is step down transformer, its step-down 11/22/33 KV to utilisation voltage 3-Ph 400 volt, It is designed Delta-Star 3. Distributor (Secondary distribution System): It is 3-Ph Four-Wire System (R-Y-B-N) and Voltage level 3-Ph 400 Volt, for single phase supply voltage is 230 volt 4. Service mains: It is a cable connecting distributor (conductor) to consumer's terminals energy meter. Size of service wire depends on load.			
Q.4 b)	Attempt any ONE of the following :			06 Marks
i)	Describe the phenomenon of corona. Discuss about corona formation. State the advantages and disadvantages of corona.			
Ans:	Phenomenon of corona and corona formation: (2 Mark) When AC Voltage given across two conductors separated by distance 'd' as shown figure is increased greater than breakdown voltage of air i.e. 30KV/cm, then air around the conductor gets ionized and ionized air is conducting under this condition corona will takes place (form) . During corona following observations are noted: ➤ Luminous violet glow occurs around the conductor. ➤ Hissing sound will produce. ➤ Ozone gas will produce. This phenomenon is known as "corona" effect.			



Advantages of Corona:-

(Any Two advantages are expected : 1 Mark each)

1. Due to formation of corona air around the conductor gets ionized. Hence effective diameter of conductor increases. So its resistance decreases. (Since $R = \rho \frac{l}{A}$)
2. It reduces electrostatic stresses as cross section of conductor's increases.
3. It provides safety valve against over voltage due to lightning stroke.
4. It reduces effect of transient produced by surge.

Disadvantages of Corona:-

(Any Two disadvantages are expected : 1 Mark each)

1. There is power loss due to corona which reduces transmission efficiency.
2. Ozone gas produced, due to chemical action there is possibility of corrosion (rusting) of hardware & conductor.
3. Harmonics are produced which will cause radio interference due to corona.
4. There is electromagnetic & electrostatic interference due to corona.

ii) Classify substation on the basis of: 1) Service requirement 2) Constructional features

Ans:

1. According to nature of service or Application:- (Any Three point expected :1 Mark each)

1. **Transformer Sub-station:-** Those sub-station which change the voltage level of electric supply is called transformer sub-station.
2. **Switching sub-station:-** This sub-station does not change the voltage level.
3. **Power Factor correction sub-station:-** These sub-station which improve the power factor of the system. It is located at receiving substation.

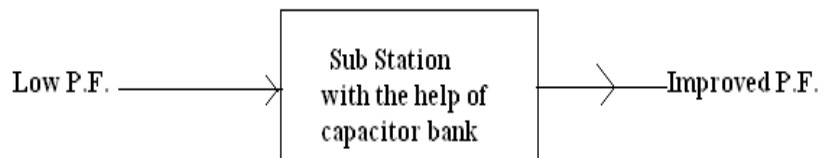

i.



4. **Frequency changer sub-station:-** These sub-station which change the supply frequency.

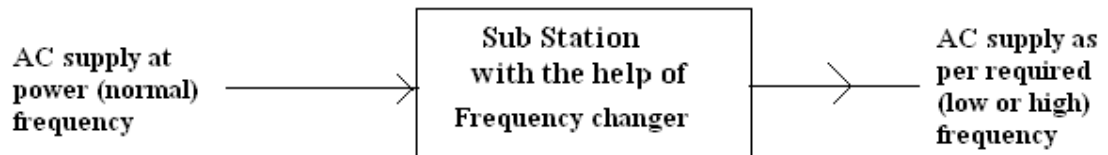

5. **Converting sub-station:-** These sub-station which change AC power into DC power or DC power into AC power

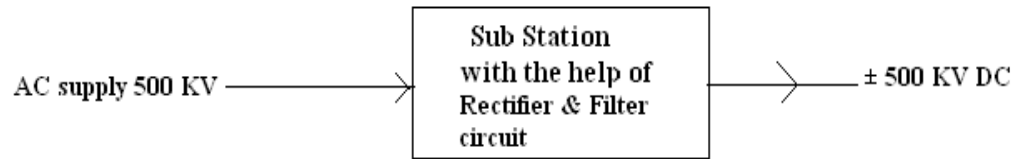

6. At receiving end, this DC supply is again converted into AC supply with the help of

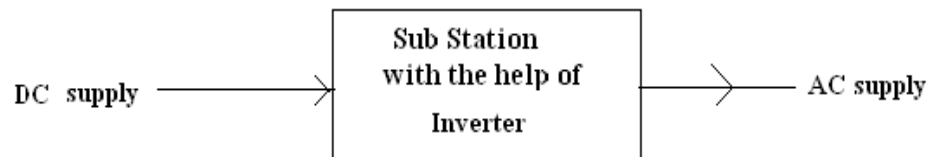

7. **Industrial Sub-station (Bulk Supply Industrial Consumer Substation):-** These sub-station which supply power to individual industrial consumer. It is located in premises of

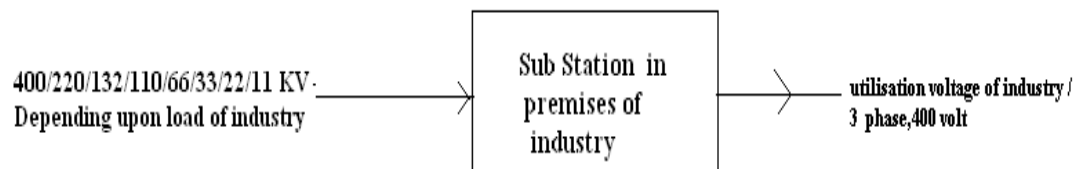

industry



8. **Traction substation:** These sub-station which supply power to electric railway only.

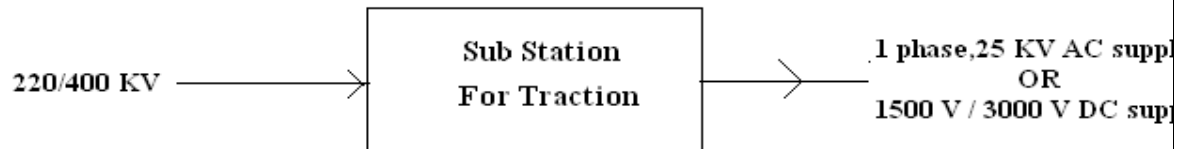

9. **Mining Substation:** The mining substations are very special type of substation & they need special design construction because of extra precautions for safety needed in the operation of electric supply

10. **Mobile Substation:** The mobile sub stations are also very special purpose substation temporarily required for big construction purpose this substation fulfils the temporary power requirement during construction work, exhibition, Remote place need supply for any type of activity etc.

2. According to Method of Construction:-

(Any Three point expected :1 Mark each)

1. **Indoor Substation:** In this substation all equipments including transformer are installed under closed construction building is called indoor substation.
2. **Outdoor Substation:** In this substation all equipments including transformer are installed in air (Open to sky) only control room is constructed is called outdoor substation
3. **Gas insulated Substation:** Where Space available is very less then GIS substation are used (e.g. substation is preferred in thickly populated area, Space available for building & equipments is limited and where cost of land is very high.).
4. **Underground Substation:** In underground substation all equipments including transformer are installed under closed construction in underground.
5. **Pole mounted substation:** Generally distribution transformer substation are pole mounted.
6. **Plinth Substation:** Generally large capacity transformers are plinth mounted because its weight is high. Transformer 315 KVA & above are generally plinth mounted.
7. **Compact/prefabricated substation:** Nowadays compact or prefabricated distribution substations are more popular. Its appearance is better than pole mounted and plinth mounted distribution substation.



Q.5	Attempt any FOUR of the following :	16 Marks
a)	State different types of line insulators. Describe any one of them.	
Ans:	<p>Types of line insulators: - (Any Four Types expected : 3 Mark)</p> <ol style="list-style-type: none">1. Pin type insulator2. Suspension or Disc type insulator.3. Strain type insulator.4. Shackle type insulator.5. Stay or Guy or Egg type insulator. <p>Explanation of Line Insulator : (Any one explanation are expected : 1 Mark)</p> <p>1) Pin type insulator</p> <ul style="list-style-type: none">➤ It is vertical in Shape.➤ Its size depends on voltage level. As voltage level increases size increases. <p>2) Suspension or Disc type insulator.</p> <ul style="list-style-type: none">➤ It has round, disc type shape.➤ Disc insulators are provided with ball & socket <p>3) Strain type insulator.</p> <ul style="list-style-type: none">➤ Strain type insulator consists of assemble of suspension insulator used in horizontal direction.➤ Function of strain insulator is to reduce excessive tension on line. Also on supporting structure. <p>4) Shackle type insulator.</p> <ul style="list-style-type: none">➤ These insulators are clamped to the cross arms by one metal ‘U’ clamp with the help of bolts, nuts & washers.➤ Function of Shackle insulator is to reduce excessive tension on line. Also on supporting structure (pole). <p>5) Stay or Guy or Egg type insulator.</p> <ul style="list-style-type: none">➤ Stay insulator are used in stay wire. It is wound (fixed) at 3 meter height from ground level.➤ Function of stay insulator to protect animals, human against shock due to leakage current.& also it increases strength of stay wire.	



b)	<p>Define transposition of conductors. State why transmission line conductors are transposed.</p> <p style="color: red; text-align: center;">(Meaning : 2 Mark & Necessity: 2 Mark)</p>
Ans:	<p>Meaning of Transposition of conductor :</p> <p>Transposition of conductor means exchanging the position of 3 phases (R-Y-B) at regular interval.</p> <p>Each phase occupies 3 different positions consequently on line support (Tower) as shown in fig.</p> <p style="text-align: center;">OR</p> <p>Transposition of line conductors means changing the positions of 3 phases on the line supports <u>twice over the total length of the line</u></p> <p>Figure of Transposition of conductor:</p> <div style="text-align: center;"> </div> <p>The necessity (reason) of Transposition of conductors:-</p> <ul style="list-style-type: none"> ➤ Due transposition of conductor inductance of each line is same $L_A = L_B = L_C$, So drop due to inductive reactance in each line is same so voltage at receiving end between any two line become same. ➤ So to obtain same voltage in any two line at receiving end ($V_{RY} = V_{YB} = V_{RB}$) transposition is necessary. ➤ Radio interferences are less due to transposition.
c)	<p>A 1 - phase transmission line is delivering 500 kVA load at 2 kV. It's resistance is 0.2 ohm and inductive reactance is 0.4 ohm. Determine voltage regulation, if the load power factor is 0.707 leading.</p>
Ans:	<p>$\therefore \cos\phi_R = 0.707 \therefore \sin\phi_R = 0.707$ Resistance 0.2 ohm Reactance 0.4 ohm</p> <p>To calculate current</p> <p style="text-align: right;">Power in KW= KVA×P.F.----- (1/2 Mark)</p> <p style="text-align: center;">=500×0.707</p> <p style="text-align: right;">=353.5Kw .----- (1/2 Mark)</p>



Step 3: To calculate Sending end voltage:

Power P = VI cos ϕ ----- (1/2 Mark)

$$I \equiv \frac{P}{V \cos \phi} \quad I \equiv \frac{353.5}{2 \times 0.707}$$

I ≅ 250 amp ----- (1/2 Mark)

Step 3: To calculate Sending end voltage:

$$V_s = V_R + I(R_T \cos \phi_R - X_T \sin \phi_R) \text{ ----- (1/2 Mark)}$$

$$= 2 \times 10^3 + 250(0.2 \times 0.707 - 0.4 \times 0.707)$$

$$= 2000 - 35.35$$

$$= 1964.65 \text{ volt}$$

V_s = 1.96465KV ----- (1/2 Mark)

Step 4: To calculate voltage regulation:

$$\% \text{ Voltage Regulation} = \frac{V_s - V_R}{V_R} \times 100 \text{ ----- (1/2 Mark)}$$

$$= \frac{1.96465 - 2}{2} \times 100$$

----- (1/2 Mark)
= - 1.7675 %

d) Compare AC distribution and DC distribution system.

Ans: (Any Four Point Expected : 1 Mark each)

Sr.No	A.C Distribution System	D.C Distribution System
1	It require Four conductor	It require Two / Three conductor
2	More complicated system	It is simple system
3	Presence of skin effect	No skin effect



MAHARASHTRA STATE BOARD OF TECHNICAL EDUCATION
(Autonomous)
(ISO/IEC-27001-2005 Certified)

SUMMER– 2015 Examinations

Subject Code: 17417

Model Answer

Page 26 of 32

	4	Effective resistance of conductor is more	Effective resistance of conductor is less	
	5	Losses are more	Losses are less	
	6	Distribution Efficiency is less	Distribution Efficiency is more	
	7	Effect of L & C Present	Effect of L & C Zero (absent)	
	8	Voltage regulation is poor	Voltage regulation is better	
e)	Compare Indoor and outdoor substation on the basis of: (i) Space required for substation (ii) Time required for erection (iii) Fault location (iv) Capital cost			
Ans:	(Each Point : 1 Mark)			
	Sr. No.	Points	Indoor substation	Outdoor substation
	1	Space Require	Less	More
	2	Time required for completion	More, as construction work is more.	Less, as construction work is less.
	3	Fault location	Difficult, as all equipments are not easily viewed.	Easy, as all equipments are easily viewed.
	4	Capital cost	High, as construction work cost is more.	Less, as construction work cost is less.
Q.6	Attempt any TWO of the following :		16 Marks	
a)	State the concept of string efficiency. Describe the different methods to improve string efficiency.			
Ans:	Concept of string efficiency :			(4 Marks)
	String Efficiency:-			
	Unequal potential distribution along a string of suspension insulator is usually expressed in terms of string efficiency.			



$$\text{String \% } \eta = \frac{\text{voltage across whole string } (V_{ph} = V_L / \sqrt{3})}{n \times \text{voltage across disc nearer to conductor}} \times 100$$

$$\text{String } \eta \% = \frac{V_{ph}}{n \times V_n} \times 100$$

Where, n = Number of Disc insulators, V_n = Voltage across disc nearer to conductor\

OR

- i) Uniformity of potential distribution along a string of suspension insulator.
- ii) Greater string efficiency means more uniform voltage distribution along a string of suspension insulator.
- iii) 100 % string efficiency means voltage across each disc of a suspension insulator is equal.

OR

The Methods of Improving String Efficiency:-

- 1) By reducing value of 'm' or ('k') by using longer cross arm.
- 2) By Making of 'm' or ('k') equal to zero
- 3) By grading Insulator.
- 4) By Using guard ring.

Description :-

(Method explanation:4 Mark each)

- 1) By reducing value of 'm' or ('k') by using longer cross arm:

The value of 'm' can be decreased by reducing value of shunt capacitance (C_1)
since $m = C_1/C$.

- 2) By Making of 'm' or ('k') equal to zero :

If an insulating material or any non conducting material of high strength is used



	<p>for connection between two disc insulators in a string instead of using steel part.</p> <p>Than value of Shunt Capacitance (C1) becomes Zero,(Capacitance will not form) therefore value of 'm' becomes zero (since $m = C_1/C$) So string efficiency becomes 100%.</p> <p>3) By grading Insulator:</p> <p style="padding-left: 40px;">In this method, disc insulators of different dimensions are so selected that each disc has different capacitance. The assembly in the string of suspension insulator is made in such a way that the top unit insulator has fewer dimensions. ($C \propto A$) and dimensions of insulators progressively goes on increasing i.e. bottom unit has maximum capacitance due to large dimensions of insulators.</p> <p>4) By Using guard ring:</p> <p style="padding-left: 40px;">Guard ring is a metal ring electrically connected to conductor and surrounding the bottom insulator. Due to guard ring leakage current through all discs in a string is same.</p> <p style="padding-left: 40px;">So, we will get uniform voltage distribution along the string of suspension insulator, In this way string efficiency increases.</p>
b) i)	<p>Write down sending end voltage, sending end current by using generalised circuit constants of transmission line. Mention the important points about it.</p>
Ans:	<div style="text-align: center;"> </div> <p>A transmission line is two port networks. Two input terminals where power enters the network & two output terminals where power leaves the network.</p> <p>The input voltage, sending end voltage (V_S) & sending end current of a 3-ph transmission line can be expressed as</p> $\vec{V}_{Sph} = A \vec{V}_{Rph} + B \vec{I}_R \text{-----sending end voltage----- (1 Mark)}$ $\vec{I}_S = C \vec{V}_{Rph} + D \vec{I}_R \text{-----sending end current----- (1 Mark)}$



$$A = \frac{V_{S\text{ ph}}}{V_{R\text{ ph}}} \text{----- Voltage Ratio}$$

$$B = \frac{V_{S\text{ ph}}}{I_R} \text{----- Impedance in ohm}$$

$$C = \frac{I_S}{V_{R\text{ ph}}} \text{----- Conductance in mho}$$

$$D = \frac{I_S}{I_R} \text{----- Current Ratio}$$

Two important points:-

For a Given transmission line:

$$\vec{A} = \vec{D} \text{----- (1 Mark)}$$

$$\vec{A} \vec{D} - \vec{B} \vec{C} = 1 \text{----- (1 Mark)}$$

A, B, C, D constants are generally complex number

b) ii) Draw a typical layout diagram of 11 kV distribution substation.

Ans:

typical layout diagram of 11 kV distribution substation

(4 Mark)

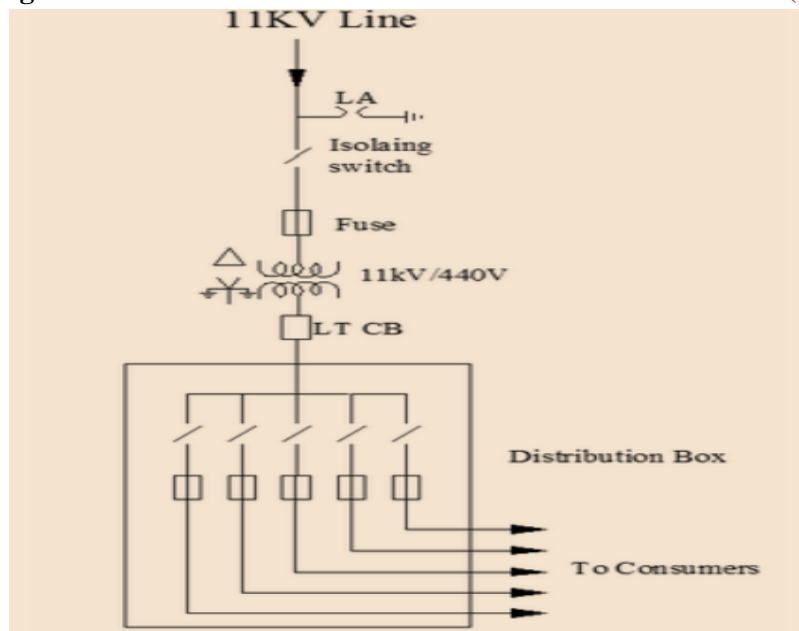

OR

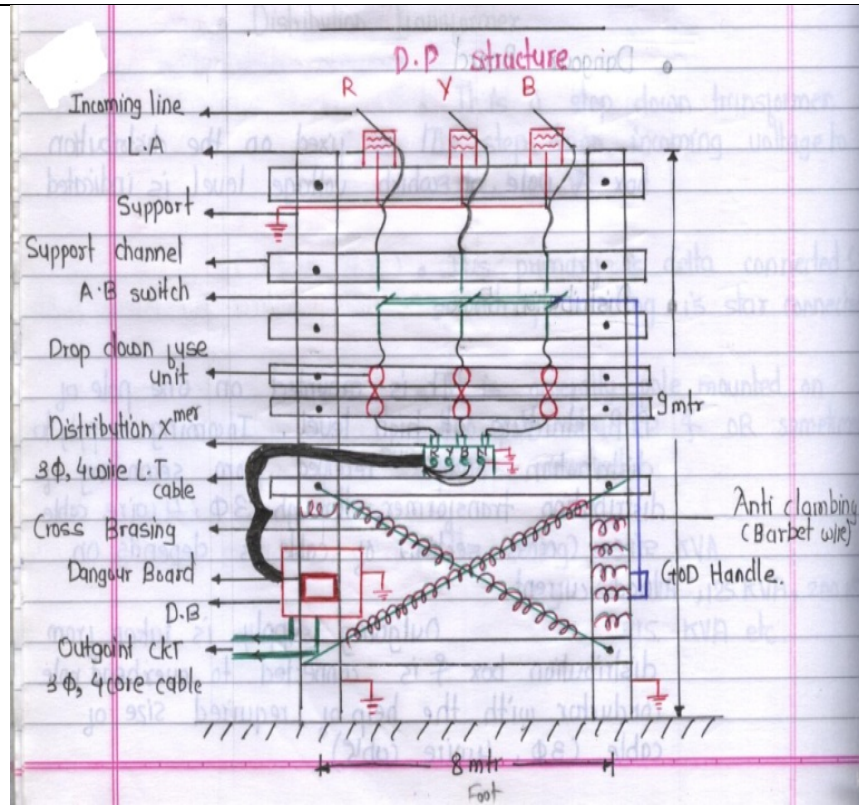

OR

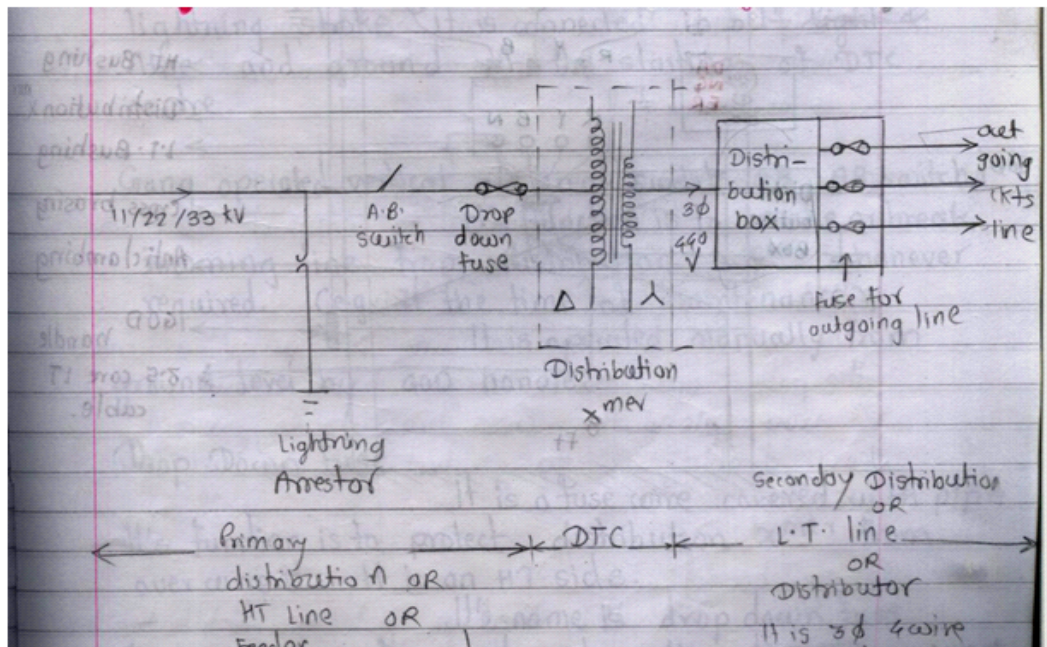



c) A single phase A.C. distributor AB 300 meters long is fed from end A and loaded as under:
(i) 100 A at 0.707 p.f. lagging 200 m from point A.
(ii) 200 A at 0.8 pi lagging 300 m from point A.
The load resistance and reactance's of distributor is 0.2 ohm and 0.1ohm per kilometer. Calculate the total voltage drop in the distributor. The load power factors refer to the voltage at the far end.

Ans:

Given data:

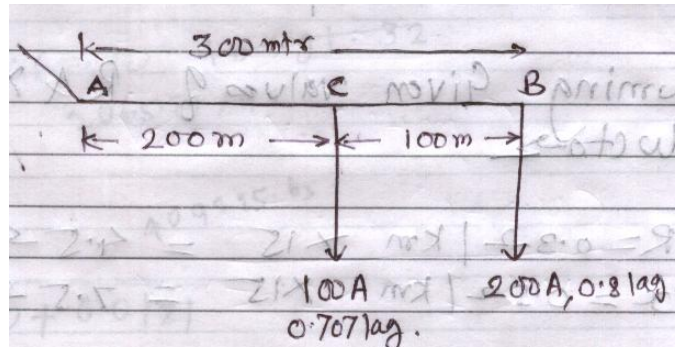

$$R = 0.2 \text{ ohm/km} \quad X = 0.1 \text{ ohm/km} \quad \therefore Z = (0.2 + j0.1)\Omega/\text{km}$$

Section Impedance:-

$$Z_{AC} = \frac{200}{1000} (0.2 + j0.1) \text{----- (1/2Marks)}$$

$$Z_{AC} = 0.04 + j0.02$$

$$Z_{AC} = 0.0447 \angle 26.57^\circ \text{ ohm ----- (1/2Marks)}$$

$$Z_{CB} = \frac{100}{1000} (0.2 + j0.1) \text{----- (1/2Marks)}$$

$$Z_{CB} = 0.02 + j0.01$$

$$Z_{CB} = 0.022 \angle 26.57^\circ \text{ ohm ----- (1/2Marks)}$$

Section Current:

Given, $I_C = 100\text{A}$, 0.707 lag

$$100 \angle -45^\circ$$

$$70.71 - j70.71 \text{ Amp ----- (1/2Marks)}$$

Given, $I_B = 200\text{A}$, 0.8 lag

$$200 \angle -36.87^\circ$$

$$160 - j120 \text{ Amp ----- (1/2Marks)}$$



Section Current: $I_{CB} = I_B$

Section Current: $I_{AC} = I_C + I_B$ ----- (1/2Marks)

$$= (70.71 - j70.71) + (160 - j120)$$

$$= 230.71 - j190.71$$

$$= 299.3282 \angle -39.5778 \text{ Amp} \text{----- (1/2Marks)}$$

Voltage drop in section CB:-

$$= I_{CB} \times Z_{CB} \text{----- (1/2Marks)}$$

$$= (299.3282 \angle -39.5778) (0.02236 \angle 26.565)$$

$$= 6.69 \angle -13.01 \text{ Volts}$$

$$= 6.5182 - j1.5060 \text{ Volts} \text{----- (1/2Marks)}$$

Step III:

Voltage drop in section AC:-

$$V_{AC} = I_{AC} \times Z_{AC} \text{----- (1/2Marks)}$$

$$= (299.3282 \angle -39.5778) (0.0447 \angle 26.57)$$

$$= 13.37997054 \angle -13.0078 \text{ V}$$

$$= 13.0366 - j 3.01161 \text{ V} \text{----- (1 Mark)}$$

Total Voltage drop:-

Voltage drop in section CB + Voltage drop in section AC---- (1/2Marks)

$$= (6.5182 - j 1.5060) + (13.0366 - j 3.01161)$$

$$= 19.5548 - j 4.51761 \text{ Volt} \text{----- (1 Mark)}$$

$$= 20.0698 \angle -13.0084 \text{ Volt}$$

-----END-----