



WINTER- 18 EXAMINATION

Subject Name: Thermal Engineering

Model Answer

17410

Important Instructions to examiners:

- 1) The answers should be examined by key words and not as word-to-word as given in the model answer scheme.
- 2) The model answer and the answer written by candidate may vary but the examiner may try to assess the understanding level of the candidate.
- 3) The language errors such as grammatical, spelling errors should not be given more Importance (Not applicable for subject English and Communication Skills).
- 4) While assessing figures, examiner may give credit for principal components indicated in the figure. The figures drawn by candidate and model answer may vary. The examiner may give credit for any equivalent figure drawn.
- 5) Credits may be given step wise for numerical problems. In some cases, the assumed constant values may vary and there may be some difference in the candidate's answers and model answer.
- 6) In case of some questions credit may be given by judgement on part of examiner of relevant answer based on candidate's understanding.
- 7) For programming language papers, credit may be given to any other program based on equivalent concept.

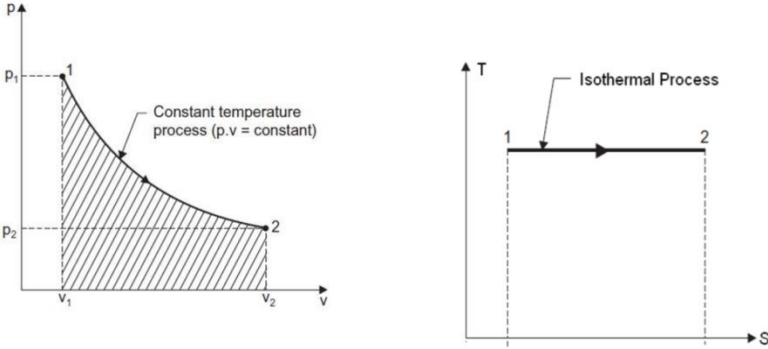
Q.NO.	Sub. Q.No.	Answer	Marking Scheme
Q.1(a)	i)	<u>Intensive Property</u> - The properties are independent on mass of system is known as Intensive Properties. Example-Pressure, Temperature.	2
	ii)	<u>Kelvin Plank Statement</u> - It is impossible to construct a heat engine which while operating in a cyclic process, will produce no effect other than transfer heat from single thermal reservoir and performance an equivalent amount of work.	2
	iii)	<u>Boyle's Law</u> - When a perfect gas is heated at constant temperature, the volume of given mass of gas is inversely proportional to absolute pressure. $V \propto 1/P$, $PV=C$.	2
	iv)	<u>Isothermal Process</u> - 	2
	v)	<u>Boiler Mounting</u> -These are fitting or mounting on boiler for safety of boiler and for complete control over the processes of steam generation. a) Safety valve b) water level indicator c) Fusible plug d) pressure gauge e) steam stop valve f) feed check valve (Any Two)	2



(b)	vi)	Four losses in steam turbine(any four) 1) Friction losses 2) Leakage losses 3) Exhaust losses 4) Radiation and convection losses 5) Losses due to moisture 6) Admission loss 7) Carry over loss	2
	vii)	<u>Condenser efficiency</u> - It is defined as 'the ratio of rise in temperature of cooling water to the difference between the saturation temperature to absolute pressure in condenser and inlet temperature of cooling water. ' Or It is defined as the ratio of actual rise in the temperature of cooling water to the maximum possible rise.	2
	viii)	<u>Fourier law of heat conduction</u> - It state that 'for homogeneous material, the rate heat transfer in steady state in any direction is linearly proportional to temperature gradient in that direction. '	2
	i)	1) <u>Dryness fraction</u> - is define as,'the amount of dry steam in one kg of wet steam.' Denoted by 'x' 2) <u>Enthalpy of wet steam</u> - It is quantity of heat required to convert 1 kg of water at 0c. in wet steam having dryness fraction x at constant pressure. 3) <u>Enthalpy of dry saturated steam</u> - the quantity of heat required to convert 1 kg of water at 0c into dry saturated steam at constant pressure. 4) Enthalpy of superheated steam- The quantity of heat required to convert 1 kg of air at 0c into superheated steam.	EACH 1
	ii)	Function of cooling tower is that hot water coming out from condenser is feed to the tower on top and allow to tickle in form of thin sheets or drop. Air flows from bottom of tower or perpendicular to direction of water flow and then exhausts to atmosphere after effective cooling of water. Uses- 1) For cooling hot water from condenser in thermal power plant. 2) For supply of water to steam power plant when less water is available.	2 2
	iii)	Heat exchanger are classified as 1) Direct contact or open heat exchanger 2) In direct contact 3) Parallel flow 4) Counter flow 5) Concentric flow 6) Shell and tube type 7) Multiple shell and tube passes Application- 1) In refrigerating system 2) Radiator of automobile 3) Solar water system 4) Regenerators 5) Milk chiller of pasteurising plant	2 2

Q 2

a)

Thermodynamic system- it is specific portion of matter with definite boundary is called system which is for study or analysis of problem.

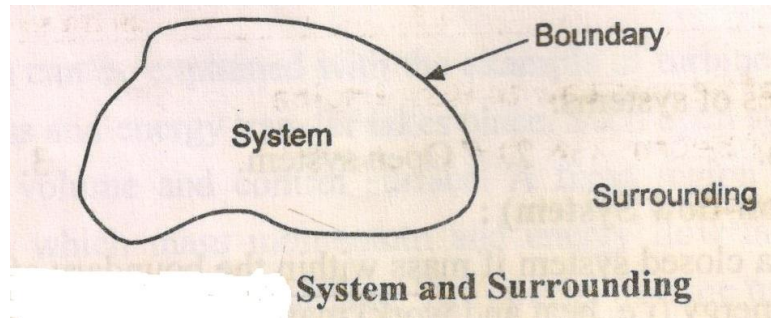

1

It is classified as follows-

- 1) Closed system- There is no mass transfer between systems and surrounding only energy crosses the boundary.
e.g. heating of water in closed vessel.

1

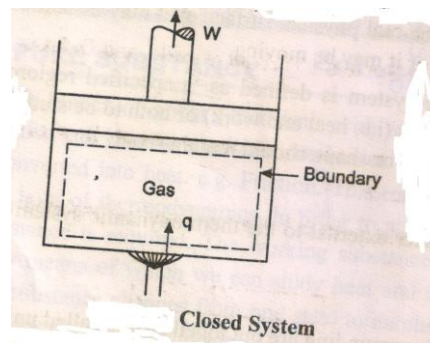

- 2) Open system- In this system mass as well as energy crosses boundary system or transfer of mass and energy between energy and surrounding.
e.g. steam turbine.

1

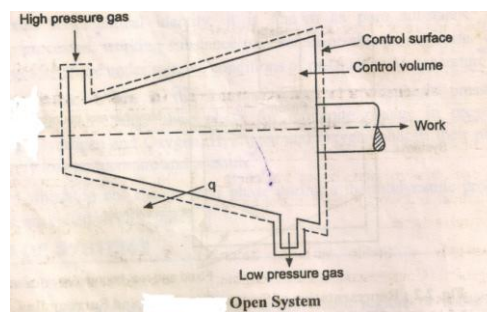

- 3) Isolated system- There is no transfer of mass and energy between system and surrounding.
e.g. thermos flask or universe

1

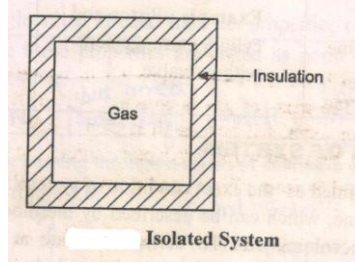

- (b) Limitation of first law of thermodynamics
- i) The first law doesn't place any restriction on direction of heat and work transfer.
 - ii) It doesn't help to predict whether system will or will not undergoes a particular change.
 - iii) No restriction has been imposed on possibility of conversion of energy from one form to another.
 - iv) It doesn't throw any light on what portion of heat may be converted into useful form of energy.
- (c) For polytropic process,
- $$\frac{T_2}{T_1} = \left(\frac{P_2}{P_1}\right)^{\frac{n-1}{n}} \quad m = 1.25$$
- $$T_2 = T_1 \left[\frac{P_2}{P_1}\right]^{\frac{n-1}{n}}$$
- $$= 250 \left[\frac{400}{250}\right]^{\frac{1.25-1}{1.25}}$$
- $$= 250 [1.6]^{0.2}$$
- $T_2 = 274.6 \approx 275K$
- Internal energy
- $$\Delta\mu = m \times cv \times (T_2 - T_1) \quad (v=0.72)$$
- $$= 2 \times 0.72 (274.6 - 250)$$
- $\Delta\mu = 35.42 \text{ KJ}$
- (d) Function of air preheater- Air preheater extract a part of heat from the work flue gases before they discharge through chimney into atmosphere. It is implied between economizer and chimney. It also supply hot air for drying the coal in combustion or fuel in
- Advantages
- 1) Improved combustion
 - 2) Successful of low fuel
 - 3) Increased thermal efficiency
 - 4) Saving in fuel consumption
 - 5) Increases steam generation capacity of boiler

(e)

Working principle of reaction turbine-

-A turbine in which steam pressure decreases gradually while expanding through the moving as well as through the fixed blade is known as reaction turbine.

-In pure reaction turbine, the drop of pressure with expansion and generation of kinetic energy take place in moving blades the steam jet leaves the moving blades at greater velocity than that they enter blades. The jet of steam leaving the moving blade with greater velocity reacts on the blades and turn them round. The passage through moving blade of reaction turbine is made convergent so the steam expand as it passes through moving blades. The expansion causes the steam to leave the moving blade as higher velocity than as which it entered.

2

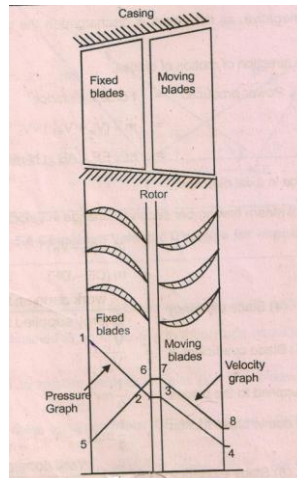

2

(f)

Working of regenerative feed heating system-

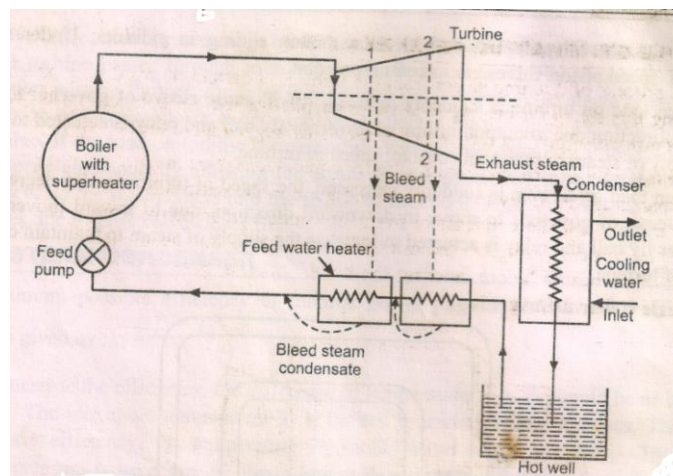

2

-The process of draining steam from turbine at certain points during its expansion and using this steam for heating feed water supplied to boiler is known as regenerative feed heating.

1



		<p><u>Two advantages-</u></p> <p>i) It increases the thermal efficiency of plant.</p> <p>ii) The temperature stresses in the boiler are reduced due to decreased range of working temperature.</p>	1
--	--	--	---

Q. No.	Sub Q. N.	Answer	Marking Scheme
Q3	(a)	<p>Attempt any FOUR</p> <p>A heat pump is a thermodynamic system operating in a cycle, which removes heat from low temperature body and delivers it to high temperature body.</p> <p>Heat pumps move thermal energy in the opposite direction of spontaneous heat transfer, by absorbing heat from a cold space and releasing it to a warmer one.</p> <p>Refrigerator: Heat is withdrawn from inside a refrigerator (low temperature). Temperature inside refrigerator drops. Extracted heat is given off to environment (higher temperature). Negligible temperature rise of the environment. $(COP)_R = Q_2 / (Q_1 - Q_2)$</p> <p>Heat pump: Heat is withdrawn from environment: air, soil, or water (low temperature). Negligible temperature drop of the environment. Extracted heat is given off into building (higher temperature). Temperature of building's interior rises. $(COP)_p = Q_1 / (Q_1 - Q_2)$; $(COP)_p = 1 + (COP)_R$</p>	<p>1</p> <p>1</p> <p>1</p> <p>1</p>
	(b)	<p>Isobaric process (Constant pressure process)</p> <p>Work done $W_{1-2} = P(V_2 - V_1)$</p> <p>$P =$ pressure ; V_1 and V_2 are initial and final volumes</p> <p>Heat transfer $Q_{1-2} = m C_p(T_2 - T_1)$</p> <p>$m =$ mass; C_p is specific heat at constant pressure; T_1 and T_2 are initial and final temp.</p>	<p>2</p> <p>2</p>

3

(c)

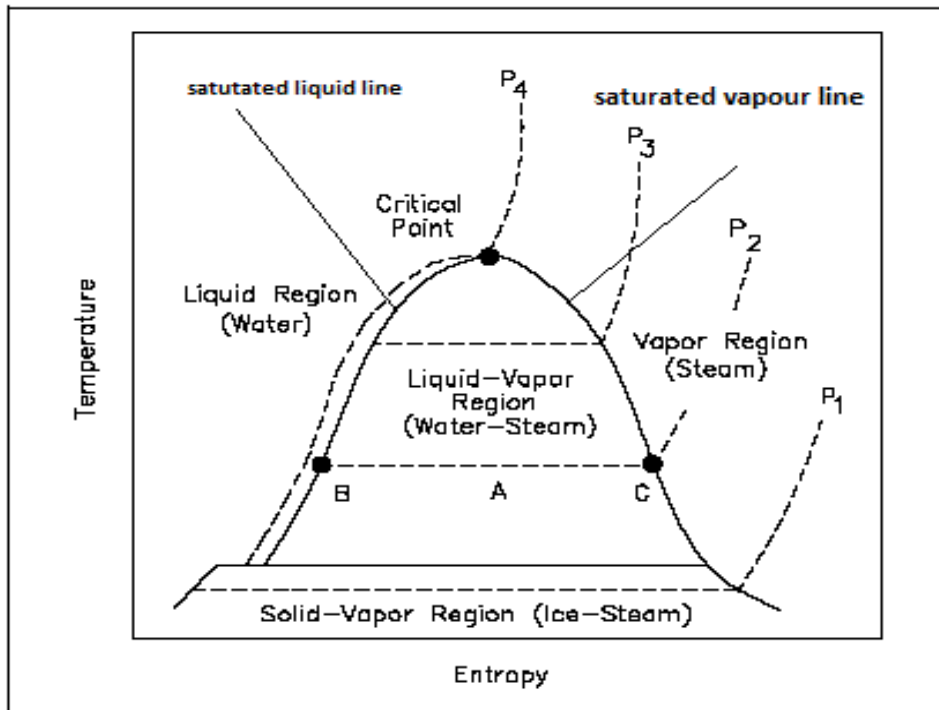

Diagram-2

Level-2

(d)

The Mach Number is a dimensionless value useful for analyzing fluid flow dynamics problems where compressibility is a significant factor. It is ratio of velocity at a state in flowing fluid to the value of sonic velocity at the same state. The Mach Number can be expressed as

$$M = v / c \quad \text{where } M = \text{Mach number} ; v = \text{fluid flow speed (m/s)} ; c = \text{speed of sound (m/s)}$$

significance:-

- If the mach number is < 1 , the flow speed is lower than the speed of sound - and the speed is **subsonic**.
- If the mach number is ~ 1 , the flow speed is approximately like the speed of sound - and the speed is **transonic**.
- If the mach number is > 1 , the flow speed is higher than the speed of sound - and the speed is **supersonic**.
- If the mach number is $\gg 1$, the flow speed is much higher than the speed of sound - and the speed is **hypersonic**

2

2

Q. No.	Sub Q. N.	Answer	Marking Scheme
	(e)	<p>The sources of air in the condenser are due to the following reasons:-</p> <ol style="list-style-type: none"> Leakage through packing glands and joints. Leakage through condenser accessories, such as atmospheric relief valve, etc. Air associated with exhaust steam may also liberate at low pressure. In the jet condenser, the dissolved air in the cooling water liberates at low 	2

pressures.

The effect of the presence of air in condenser are:

1. The pressure in the condenser is increased; this reduces the work done by the engine or turbine.
2. The partial pressure of steam and temperature are reduced. The steam tables tell us that at lower pressure, the latent heat of steam is more. To remove this greater quantity of heat, more cooling water has been supplied and, thus under cooling of the condensate is likely to be more severe resulting in lower overall efficiency.
3. The presence of air reduces the rate of condensation of steam since the abstraction of heat by the circulating cooling water is partly from the steam and partly through the air.
4. The rate of heat transfer from the vapor is reduced due to the poor thermal conductivity of air. Thus, the surface area of the tubes has to be increased for a given condenser duty.
5. An air extraction pump is needed to remove air still some quantity of steam escapes with the air even after shielding to the air extraction section. This reduces the amount of condensate. Moreover, the condensate is under cooled, with the result that more heat has to be supplied to the feed water in the boiler.

2

(f)

Shell and Coil type heat exchanger :-

(Note –Sketch of shell and tube type may also be accepted, since it also contains coils, and also mechanism of heat transfer is similar)

Here, thermal energy between two fluids at different temperatures is transferred. Both fluids are in motion and main mode of heat transfer is convection. Here, bundle of round tubes are placed in cylindrical shell . The tube bundle may be parallel to axis (shell and tube), or helical coil (shell and coil). Generally cross flow pattern is used, which gives better heat transfer.

2

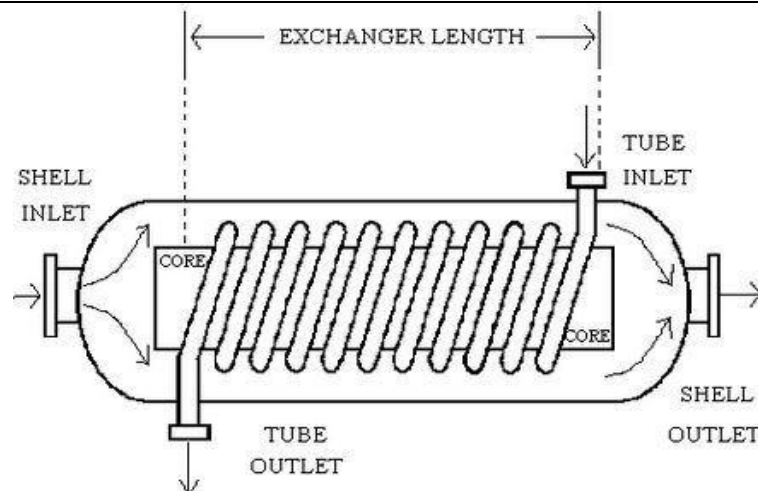

2



Q4	(a)	(i) State-It may be identified or described by some observable quantities such as volume, pressure, temp, density, which are thermodynamic properties. Minimum two properties are required to define state of system. Properties are state or point functions.	1
		(ii) Process:-When system changes its state from one equilibrium state to another equilibrium state, then the path of successive states through which, the system has passed is known as thermodynamic process.	1
		(iii) Point function: - If each property has single value at each state i. e. properties of system depends upon state of system. These properties are called as point function. e.g. pressure, temp.	1
		(iv) Path function: - The thermodynamic quantities, which are dependent on path followed between two end states of process are path functions. e.g. Work, heat	1

4	(b)	Mass of steam = 4 kg	1
		Pressure = 2MPa = 20 bar	
		From steam tables, Enthalpy $h_f = 908.69$ KJ/kg; $h_{fg} = 1890.01$ KJ/Kg; $h_g = 2798.8$ KJ/kg;	
		$s_1 = 2.447$ KJ/kg K; $s_g = 6.3396$ KJ/kg K ; $v_g = 0.09959$ m ³ /Kg	
		Enthalpy of dry saturated steam $h_g = 2798.8$ KJ/kg	
		Enthalpy of 4 kg of steam = $4 \times 2798.8 = 11195.2$ KJ/Kg	
		Specific volume = $v_g = 0.09959$ m ³ /Kg	
		Volume of 4 kg of steam = $4 \times 0.09959 = 0.398$ m ³	
		Specific Entropy = 6.3396 KJ/kg K	
		Entropy of 4 kg of steam = 25.32 KJ/K	
Internal energy of 1 kg of dry saturated steam	1		
$u = h_g - P v_g$ $= 2798.8 - [(20 \times 10^5 / 1000) \times 0.09959]$			



	<p>= 2599.62KJ/kg</p> <p>Internal energy of 4 kg of dry saturated steam =10398.48 KJ</p>	
c	<p>Principle of Forced Draught</p> <p>Fan or blower is placed before grate or situated within the oil burner assembly in case of oil fired boiler.</p> <p>Pressure inside the flue passages is slightly more than atmospheric pressure.</p> <p>Due to above reason, there is serious danger of fire to come out and injure someone if any leakage in boiler flue passage take place.</p> <p>It forces fresh air into the combustion chamber, which helps in burning of fuel and production of hot combustion gases. Due to this force, the hot flue gases are further pushed through the flue passages in boiler.</p> <p>Advantages:-Forced draught fan require less power because it has to handle cold and dense air, the volume per unit mass of which is less.</p> <p>Flow of flue gases through boiler is more uniform.</p> <p>Principle of Induced Draught</p> <p>The fan or blower is placed after the grate or after the flue passages and before chimney.</p> <p>Pressure inside the flue passages is slightly less than atmospheric pressure.</p> <p>It sucks the hot flue gases from the combustion chamber through flue passages and then passes on these to economizer, air pre heater and chimney. Due to this suction, fresh air is also sucked in to combustion chamber.</p> <p>Advantage: - Due to above reason, there is no danger of fire to come out from boiler flue passage in case of a leakage. Hence Induced draught is safer.</p>	1 1 1 1
d	<p>Nozzle control Governing in steam turbine-</p> <p>In nozzle governing the flow rate of steam is regulated by opening and shutting of sets of nozzles rather than regulating its pressure. In this method groups of two, three or more nozzles form a set and each set is controlled by a separate valve. The actuation of individual valve closes the corresponding set of nozzle thereby controlling the flow rate. In actual turbine, nozzle governing is applied only to the first stage whereas the subsequent stages remain unaffected. Since no regulation to the pressure is applied, the advantage of this method lies in the exploitation of full boiler pressure and temperature. Figure shows the mechanism of nozzle governing applied to steam turbines.</p>	2

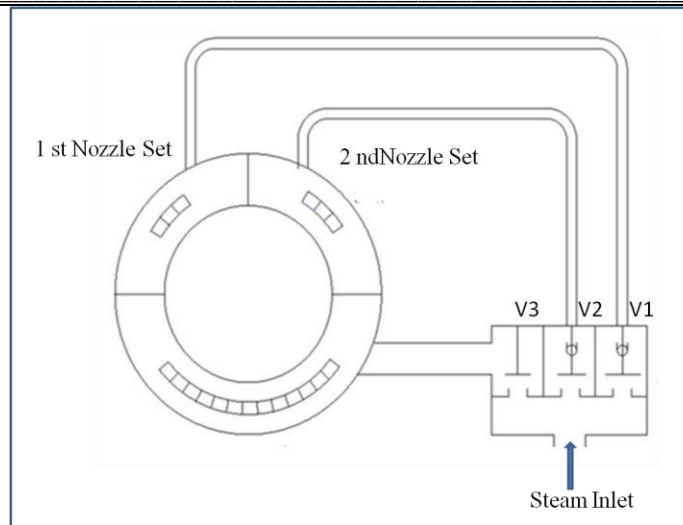

e

Condenser Efficiency

$$h_v = 710 \text{ mm of Hg}; h_b = 760 \text{ mm of Hg}; T_{wo} = 42^\circ \text{ C}; T_{wi} = 30^\circ \text{ C}$$

$$\text{Pressure in condenser } P_c = h_b - h_v$$

$$= 760 - 710 = 50 \text{ mm of Hg} = [(50/760) \times 1.01325] = 0.0666 \text{ bar}$$

At .0666 bar condenser pressure, saturation temperature $T_s = 38^\circ \text{ C}$

Condenser efficiency = $(T_{wo} - T_{wi}) / (T_s - T_{wi}) = (42 - 30) / (38 - 30) = 1.5 = 150\%$ **(Which is practically impossible). This is due to unrealistic data in question. But answer may be considered as correct for assessment, for benefit of students.**

f

When radiation strikes a surface, part of it is absorbed, part of it is reflected, and the remaining part, if any, is transmitted.

Absorptivity

Coefficient of absorptivity is defined as 'ratio of amount of energy absorbed to amount of energy incident on the body.'

Transmissivity:- Coefficient of transmissivity is defined as 'ratio of amount of energy transmitted to amount of energy incident' on the body.

Emissivity

Emissivity is defined as ability of surface of body to radiate heat, It is ratio of emissive power of any body to emissive power of black body of equal temperature. Emissivity is defined as the ratio of the energy radiated from a material's surface to that radiated from a blackbody (a perfect emitter) at the same temperature and wavelength and under the same viewing conditions. It is a dimensionless number between 0 (for a perfect reflector) and 1 (for a perfect emitter)

A **black body** is an idealized physical body that absorbs all incident electromagnetic radiation, regardless of frequency or angle of incidence. For a black body, $\tau=0$, $\alpha=1$, and $\rho=0$. Planck offers a theoretical model for perfectly black bodies, which he noted do not exist in nature: besides their opaque interior, they have interfaces that are perfectly transmitting and non-reflective.

2

4

1

1

1

1



5 a Attempt any two :

The steady flow energy equation can be written as

$$h_1 + \frac{V_1^2}{2} + gz_1 + q_{1-2} = h_2 + \frac{V_2^2}{2} + gz_2 + w_{1-2}$$

where,

h_1 = enthalpy at inlet (KJ/kg)

h_2 = enthalpy at outlet (KJ/kg)

V_1 = velocity of flow at inlet (m/s)

V_2 = velocity of flow at outlet (m/s)

z_1 = datum height from inlet (m)

z_2 = datum height from outlet (m)

q_{1-2} = heat transfer (KJ)

w_{1-2} = work done (KJ)

1) Boiler

- Boiler is a device which generates steam by supplying heat to water
- In this system no change in Kinetic Energy & potential Energy
- i.e. $K_{e2} - K_{e1} = 0$, $P_{e2} - P_{e1} = 0$
- There is no work done,

i.e. $W_{1-2} = 0$

we know SFEE for unit mass is

$$q_{1-2} - w_{1-2} = (h_2 - h_1) + (K_{e2} - K_{e1}) + (P_{e2} - P_{e1})$$

$$q_{1-2} = h_2 - h_1$$

This shows that heat supplied to the system in a boiler increases enthalpy of system.

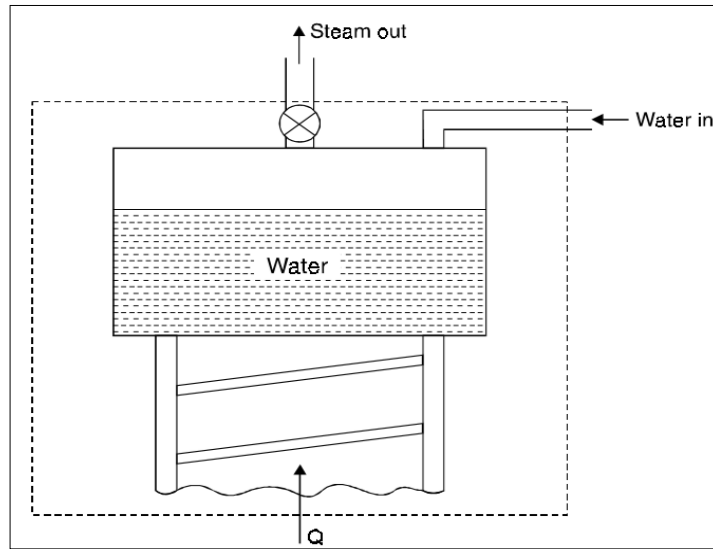

2) Nozzle:

A nozzle is a device which increases velocity of working substance.

- The nozzle is insulated so that no heat transfer takes place in system.

i.e. $q_{1-2} = 0$

- The nozzle does not deliver any work

i.e. $w_{1-2} = 0$

- There is no change in potential energy

i.e. $P_{e2} - P_{e1} = 0$

we know SFEE for unit mass flow is

$$q_{1-2} - w_{1-2} = (h_2 - h_1) + (K_{e2} - K_{e1}) + (P_{e2} - P_{e1})$$

$$0 = (h_2 - h_1) + (K_{e2} - K_{e1})$$

$$\frac{v_2^2}{2} - \frac{v_1^2}{2} = h_1 - h_2$$

$$v_2^2 - v_1^2 = 2(h_1 - h_2)$$

$$v_2^2 = 2(h_1 - h_2) + v_1^2$$

$$v_2 = \sqrt{2(h_1 - h_2) + v_1^2}$$

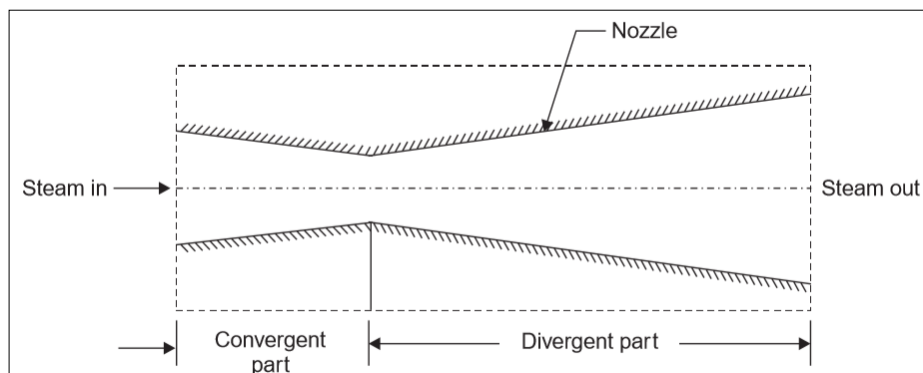

3) Turbine

A turbine is a device which converts energy of a working substance into work in turbine

- The turbine is insulated so that there is no heat transfer take place.

i.e. $q_{1-2} = 0$

- The kinetic energy & Potential Energy are negligible.

i.e. $K_{e2} - K_{e1} = 0$, $P_{e2} - P_{e1} = 0$

we know SFEE for unit mass flow is

$$q_{1-2} - W_{1-2} = (h_2 - h_1) + (K_{e2} - K_{e1}) + (P_{e2} - P_{e1})$$

$$-W_{1-2} = h_2 - h_1$$

$$W_{1-2} = h_1 - h_2$$

This shows that ~~working~~ work is done by the system due to decrease in enthalpy.

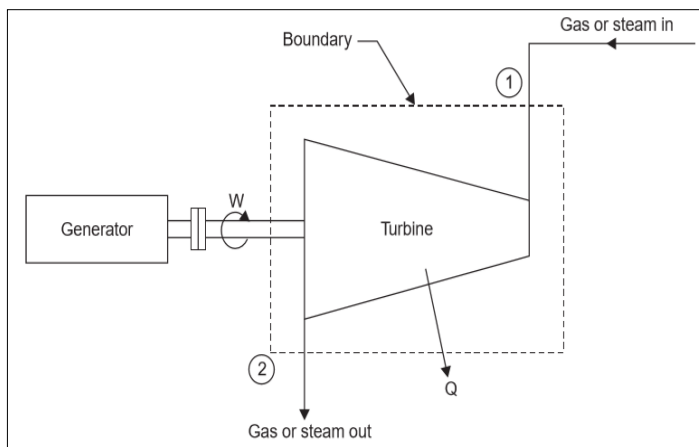

4) Condenser

A condenser is a device used to condense steam in case of power plants using water as a cooling medium.

- There is no change in kinetic energy & potential energy

i.e. $K_{e2} - K_{e1} = 0$, $P_{e2} - P_{e1} = 0$

There is no work done by the system.

i.e. $W_{1-2} = 0$

We know SFEE for unit mass flow is

$$q_{1-2} - W_{1-2} = (h_2 - h_1) + (K_{e2} - K_{e1}) + (P_{e2} - P_{e1})$$

$$-q_{1-2} = h_2 - h_1$$

as the heat is rejected from condenser to surrounding, the q_{1-2} is negative

$$q_{1-2} = h_1 - h_2$$

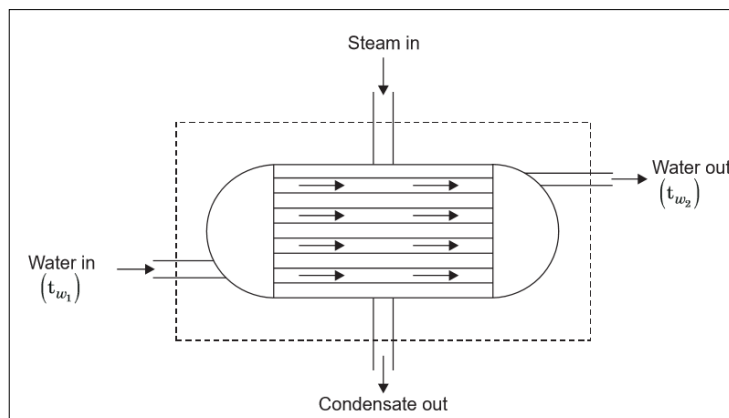



5 b

$$V_1 = 8.5 \text{ m}^3,$$

$$P_1 = 6 \text{ bar.}$$

$$T_1 = 180^\circ\text{C} = 180 + 273 = 453 \text{ K}$$

$$P_1 = P_2$$

$$V_2 = 2V_1$$

1) w 2) q 3) ΔU 4) ΔS

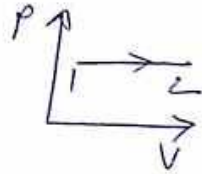

1) To find change in internal energy

$$\Delta U = m C_v (T_2 - T_1)$$

find m & T_2

$$\text{or } \boxed{P_1 = P_2}$$

$$V \propto T$$

$$\frac{V_1}{V_2} = \frac{T_1}{T_2}$$

$$T_2 = T_1 \times \frac{V_2}{V_1}$$

$$= 453 \times \frac{2V_1}{V_1}$$

$$\boxed{T_2 = 906 \text{ K}}$$



To find m , take ideal gas eqⁿ

$$PV = mRT$$

use it for initial state

$$P_1 V_1 = m R T_1$$

find out R

$$\text{or } C_p - C_v = R$$

$$1 - 0.715 = R$$

$$R = 0.285 \text{ kJ/kgK}$$

$$P_1 V_1 = m R T_1$$

or R is in kJ/kgK ; divide pressure
by 1k or 10^3

$$\frac{68 \times 10^5}{10^3} \times 3.5 = m \times 0.285 \times 453$$

$$m = 16.25 \text{ kg}$$

1) change in internal Energy

$$\Delta u = m C_v (T_2 - T_1)$$

$$= 16.25 \times 0.715 (906 - 453)$$

$$\Delta u = 5263.30 \text{ kJ}$$



2) work Transferred

$$\begin{aligned}W &= P (V_2 - V_1) \\&= mR (T_2 - T_1) \\&= 16.25 \times 0.285 (906 - 453)\end{aligned}$$

$$W = 2097.95 \text{ KJ}$$

3) Heat transferred

$$\begin{aligned}Q &= \Delta u + W \\&= 5263.30 + 2097.95\end{aligned}$$

$$Q = 7361.25 \text{ KJ}$$

4) change in Entropy

$$\begin{aligned}\Delta s &= c_p \ln (T_2/T_1) \\&= 1 \times \ln (906/453)\end{aligned}$$

$$\Delta s = 0.6931 \text{ KJ/kgK}$$

c Classification of steam condensers:

A) Jet condenser/contact type condenser

- a) Parallel flow condenser
- b) Counter flow condenser
- c) High level condenser
- d) Ejector condenser

B) Surface condenser/non contact type

- a) Down flow surface condenser
- b) Central flow surface condenser
- c) Regenerative surface condenser
- d) Evaporative surface condenser
- e) Double pass surface condenser or shell and tube type

2

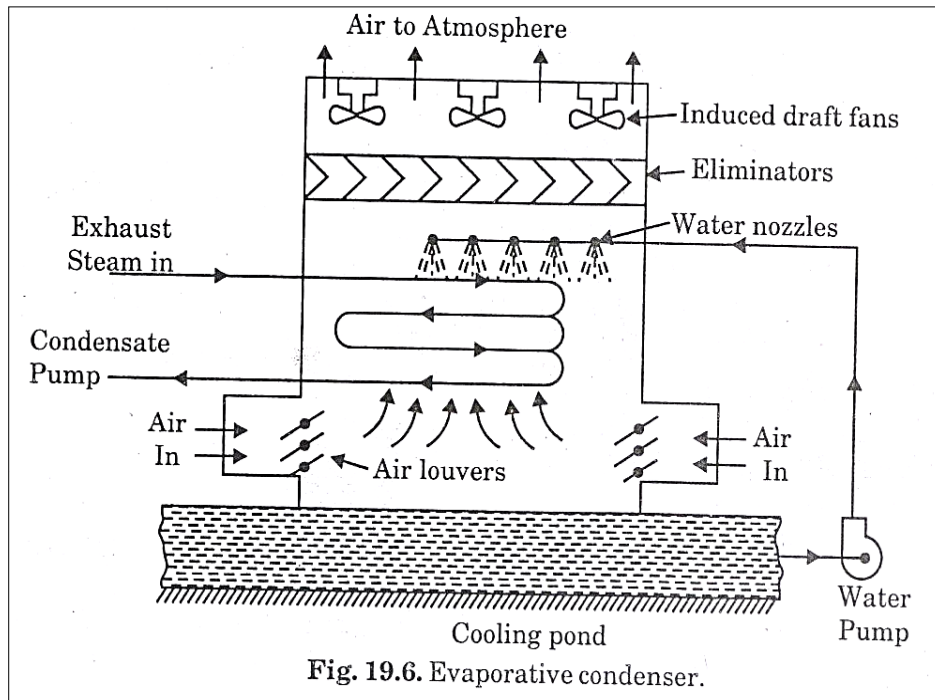

3

Working of evaporative condenser.

The refrigerant flows through the coil of the evaporative condenser. Heat from the refrigerant is rejected through the coil tubes. Part of the heat is removed directly by the downward induced air and discharged to the surrounding. Rest of the heat is rejected to the water cascading down over the tubes. Simultaneously, air is drawn in through the air inlet louvers at the base of the evaporative condenser. A small portion of the water is evaporated which removes the heat. The warm saturated air travels through the drift eliminator &

3



discharged by the fan to the surrounding, thereby reducing drift water loss. Post heat exchange, the condensed refrigerant flows to receiver tank.

6 a

Babcock and Wilcox boiler

Coal is fed to the grate through the fire door and is burnt.

Flow of flue gases: The hot flue gases rise upward and pass across the left-side portion of the water tubes. The baffles deflect the flue gases and hence the flue gases travel in the zig-zag manner (i.e., the hot gases are deflected by the baffles to move in the upward direction, then downward and again in the upward direction) over the water tubes and along the superheater. The flue gases finally escape to atmosphere through chimney.

Water circulation: That portion of water tubes which is just above the furnace is heated comparatively at a higher temperature than the rest of it. Water, its density being decreased, rises into the drum through the uptake-header. Here the steam and water are separated in the drum. Steam being lighter is collected in the upper part of the drum. A continuous circulation of water from the drum to the water tubes and water tubes to the drum is thus maintained. The circulation of water is maintained by convective currents and is known as “natural circulation”. A damper is fitted to regulate the flue gas outlet and hence the draught. The boiler is fitted with necessary mountings. Pressure gauge and water level indicator are mounted on the boiler at its left end. Steam safety valve and stop valve are mounted on the top of the drum. Blow-off cock is provided for the periodical removed of mud and sediments collected in the mud box.

4

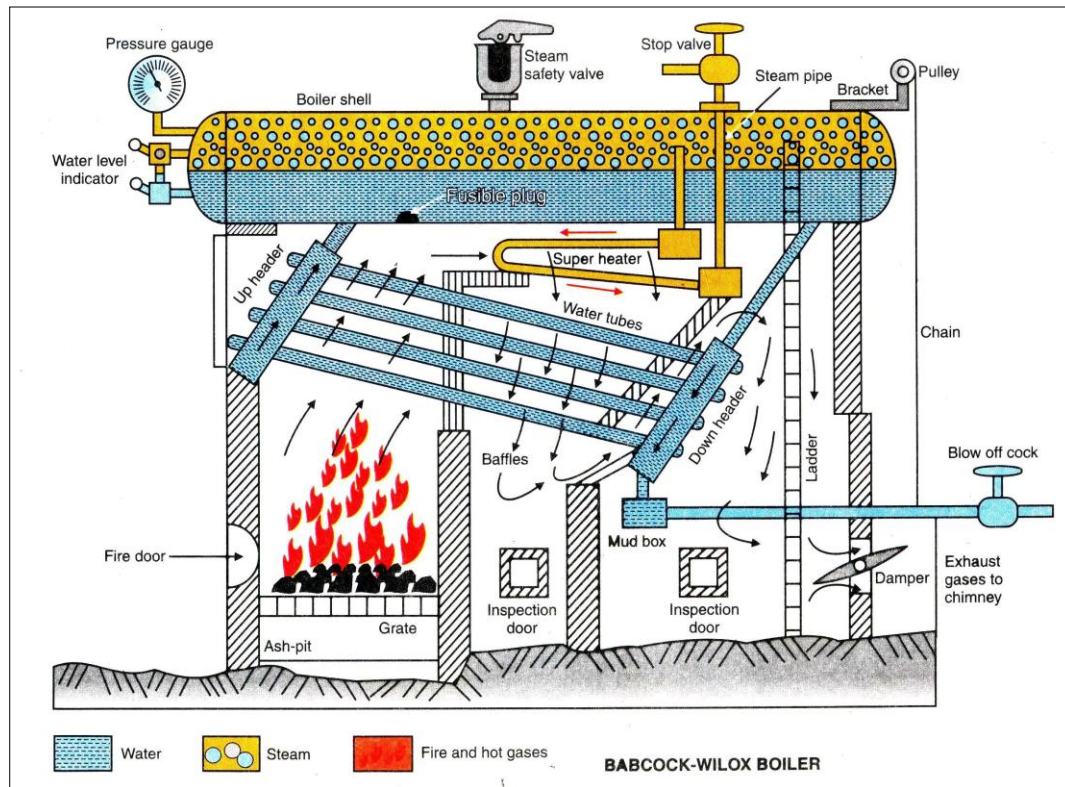

4

b **Compounding of steam turbines:-** If entire pressure drop from boiler pressure to condenser pressure is carried out in a single stage of nozzle then the velocity of steam entering the turbine blades will be very high. The turbine speed has to be also very high as it is directly proportional to steam velocity. Such high rpm of turbine rotor are not useful for practical purposes & there is a danger of structural failure of blades due to excessive centrifugal stresses. Hence compounding is carried out.

2

Compounding of steam turbines is done:

- ✓ To reduce speed of rotor blades to practical limits.
- ✓ To reduce centrifugal force and hence to prevent failure of blades.
- ✓ To reduce velocity of steam leaving blades.

Pressure compounding of steam turbines. A number of simple impulse turbine stages are arranged in series as shown in fig.

The turbine is provided with one row of fixed blade (nozzle) at the entry of each row of moving blades. The total pressure down of stream does not take place in a single nozzle but is divided among all the rows of fixed blades which work as nozzles.

2

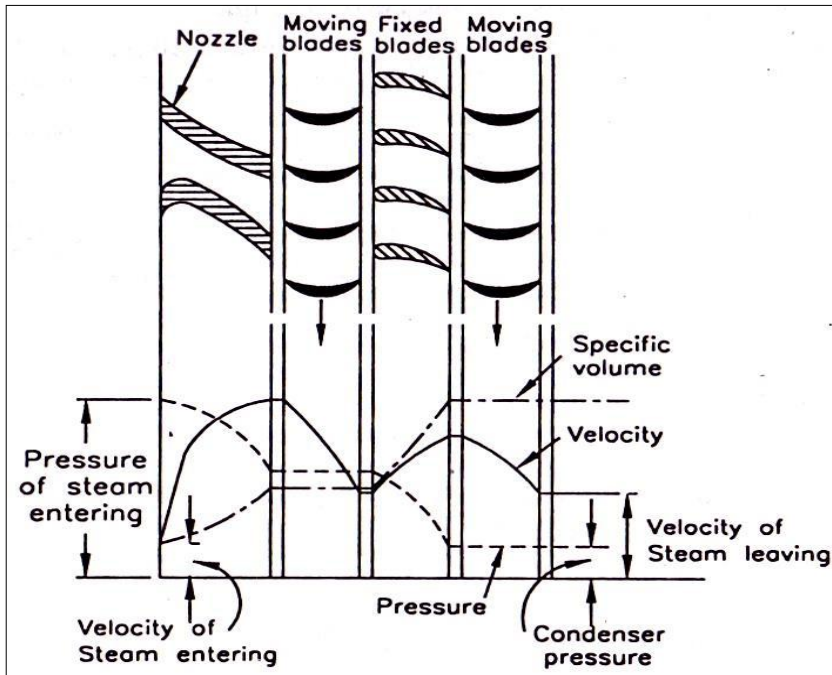

Pressure compounding of steam turbine



C

Sol \Rightarrow given

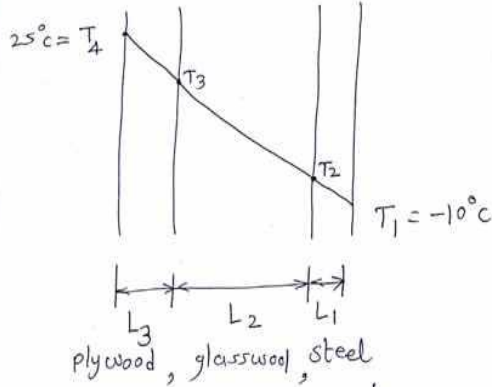

$$\begin{array}{l} K_{\text{steel}} = 23.2 \text{ W/mk} \quad L_1 = 1.6 \text{ mm} = 0.0016 \text{ m} \\ K_{\text{glasswool}} = 0.14 \text{ W/mk} \quad L_2 = 4 \text{ cm} = 0.04 \text{ m} \\ K_{\text{plywood}} = 0.052 \text{ W/mk} \quad L_3 = 13 \text{ mm} = 0.013 \text{ m} \end{array}$$

The rate of heat transfer through composite wall is given by

$$Q = \frac{(T_1 - T_4)}{\frac{L_1}{K_1 A} + \frac{L_2}{K_2 A} + \frac{L_3}{K_3 A}}$$

$$Q = \frac{-10 - 25}{\frac{0.0016}{23.2} + \frac{0.04}{0.14} + \frac{0.013}{0.052}} = \frac{-35}{6.89 \times 10^{-5} + 0.2857 + 0.25}$$

$$Q = -65.3350 \text{ Watts}$$

Negative sign indicates that heat is flowing from outside to inside

8