

Chapter 2

Network Topologies and Network Control Devices

1.1 Introduction

Physical Structures:

A network is two or more devices connected through links. A link is a communications pathway that transfers data from one device to another. For visualization purposes, it is simplest to imagine any link as a line drawn between two points. For communication to occur, two devices must be connected in some way to the same link at the same time. There are two possible types of connections: point-to-point and multipoint.

Point-to-Point

A point-to-point connection provides a dedicated link between two devices. The entire capacity of the link is reserved for transmission between those two devices. Most point-to-point connections use an actual length of wire or cable to connect the two ends, but other options, such as microwave or satellite links, are also possible. When you change television channels by infrared remote control, you are establishing a point-to-point connection between the remote control and the television's control system.

E.g.: -

- 1) PC to modem.
- 2) Workstation to workstation.
- 3) Server or mainframe to workstation.
- 4) PC to printer.
- 5) Microwave to microwave.
- 6) TV to remote control.

When a point-to-point subnet is used important interconnection topology. It should look like in Fig (a)

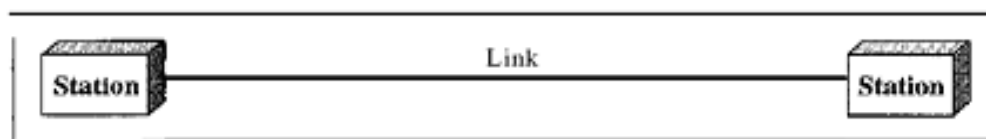

a. Point-to-point

Multipoint (multi-drop)

A multipoint (also called multi-drop) connection is one in which more than two specific devices share a single link. In a multipoint environment, the capacity of the channel is shared, either spatially or temporally. If several devices can use the link simultaneously, it is a *spatially shared* connection. If users must take turns, it is a *timeshared* connection.

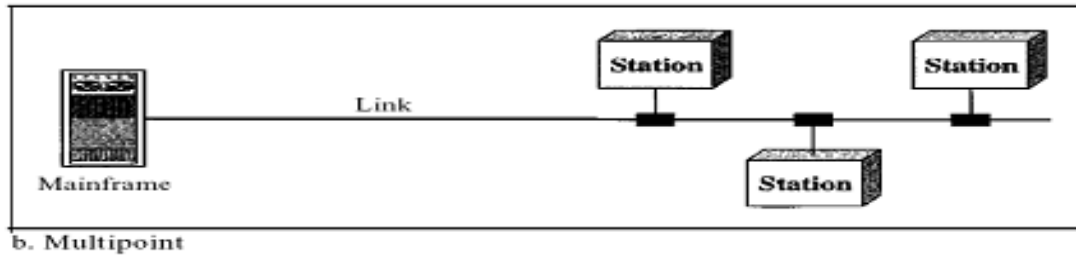

Fig. Multi Drop Network

Topology

It defines physical or logical arrangement of links in network. Topology is physical **layout of computers, cables and other connected devices** on a network. The term topology refers to the way a network is laid out either physical or logically two or more devices connect to a link or more links form a topology. The topology of a network is the geometric representation of the relationship of all the links and linking devices (called node) to each other.

There are two types of topologies-

1. Physical Topology
2. Logical Topology

Physical topology

The complete physical structure of transmission media is called physical topology. This refers to the layout of cabling, location of nodes and interconnection between the nodes and cabling.

Logical Topology

The logical topology is refers to how data is actually transferred in a network. This represents the way that data passes through the network from one device to another.

Selection Criteria for Topologies -

- Size (no. of nodes) of the system.
- Cost of the components and service required.
- Management of network.
- Architecture of network.
- Cable type.
- Expandability of the network.
- The desired performance and reliability of entire system.

Different types of topologies are:

- a. Bus Topology
- b. Ring Topology
- c. Star Topology
- d. Mesh Topology
- e. Tree and Hybrid Topology

Bus topology (Horizontal topology)

It is a multipoint. A physical bus topology network typically uses one long cable called backbone (**bus**). Short-cables called drop-cables can be attached to the backbone with the help of taps. A tap is a connector that either slices into the main cable or punctures the sheathing (covering) of a cable to create a contact with the metallic core.

As a signal travels along the backbone, some of its energy is transformed into heat. Therefore, it becomes weaker and weaker as it travels farther and farther. For this reason there is a limit on the number of taps a bus can support and on the distance between those taps.

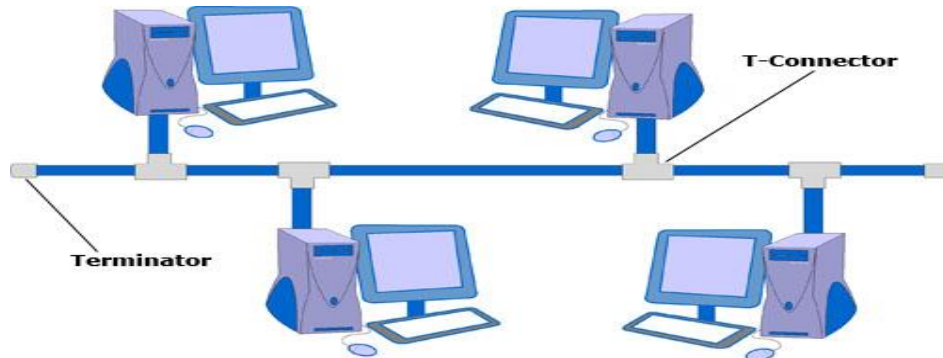

Working of Bus topology

Bus topology is often used when a network installation is small, simple or temporary. On a typical bus network the cable is just one or more wires with no active electronics to amplify the signal or pass it along from computer to computer this makes a bus a **passive topology**. When one PC sends a signal up and down the wire, all PC's on network receive the information as it is broadcasting. But only one (the one with the address that matches the one enclosed in the message) accepts the information the rest will not respond the message.

Only one PC at a time can send a message therefor number of PC's attached to a bus network can significantly affects the speed of the network. A PC must wait until the bus is free before it can transmit. Otherwise the bandwidth will simply get waste.

Use of Terminator:

Another important issue in bus network is termination. Since the bus is a passive topology the electronic signal from a transmitting computer is free to travel the entire length of cable without termination whenever the signals reaches the end of the wire it bounces back and travels back up the wire. When a signal travels back and forth along and exterminated bus it is called ringing. To stop the signal from ringing you attach terminator at the both end of the segment. The terminator absorbs the electrical energy and stop the reflections. Cable can't be left unterminated in a bus network.

E.g.: -(Ethernet) 10 base2 also known as thin net is an inexpensive network based on bus topology.

Advantages of bus topology

1. The bus is **simple, reliable** in very small network easy to use and easy to understand.
2. **It is easy for installation**-that is backbone cable can be laid along the most convenient path that connects the nodes by drop cables of various length.
3. The bus requires less amount of cables to connect the computer together and is therefore **less expensive** than other cabling arrangements.
4. **It is easy to extend**- (by using BNC Barrel connector) two cables can be joined into one longer cable with a BNC barrel connector making a longer cable and allowing more PC to join the network.
5. **A repeater can also be used to extend a bus**- A repeater boosts the signal and allows it to travel a longer distance.
6. If one node fails others are not affected.

Demerits of bus topology

1. In case of **failure of the backbone cable**, the whole network will be affected.
2. Heavy network traffic can **slow** a bus considerably because only one PC can transmit at any time resulting in wasting a lot of bandwidth as they interrupt each other instead of communicating. The problem can get worse when more PC's are connected to a network.
3. Each barrel connector weakens the electrical signal and too many may prevent the signal from being correctly received along the bus.
4. It is **difficult to troubleshoot faults** - as bus **cable break** or malfunctioning computer.
5. A **cable break or loose connection** also cause reflection and bring down the whole network and causing all the network activity to stop.
6. Difficult for reconfiguration-E.g.: Adding new devices may therefore require modification or replacement of the backbone.

Ring Topology

In Ring topology each node is connected to the two nearest nodes so the **entire network forms a circle**. Rings are used in high performance network. A signal is passed along the ring in one direction, from device to device, until it reaches its destination. Each device in the ring incorporates a repeater. When a device receives a signal intended for another device, its repeater regenerates the bits and passes them along.

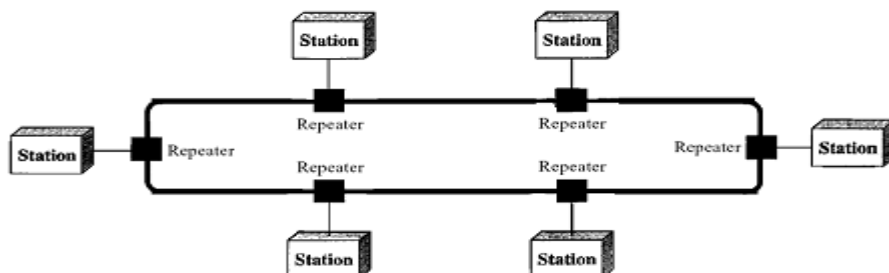

Working of ring topology

Every PC is connected to next computer in the ring and each transmits what it receives from the previous PC. The message flows around the ring in one direction. Since each PC retransmits what it receives a ring is an **active network**. There is no termination because there is no end to the ring.

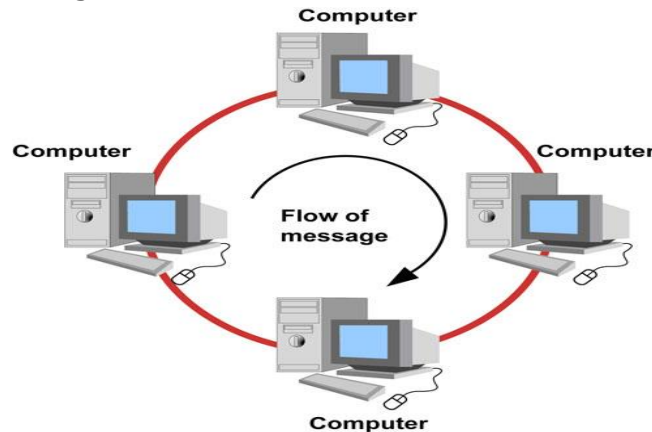

Token Ring -

Some ring networks use token passing. Token is a short message. A token is passed around the ring until a PC wishes to send information to another PC. That PC modifies the token adds an electronic address and data and sends it around the ring. Each PC in sequence receives the token and the information and passes them to the next PC until either the electronic address of computer matches or the token returns to its origin the receiving PC returns a message to originator that the message has been received. The sending PC then creates another token and begins transmitting the token. The token is circulated until the station is ready to send.

E.g.: - FDDI is a fast fiber optic networks based on ring topology. FDDI (Fiber Distributed data interface)

Advantages of ring topology

- i. A ring is relatively **easy to install** and **configure** (for fix number of devices).
- ii. **Fault isolation is simplified**- generally in a ring a signal is circulating at all time if any device does not receive a signal within the specified period. It can issue an alarm. Alarm alerts the network operator to the problem of its location.
- iii. **To add or delete a device** requires moving only two connections.
- iv. **Time to send data is known**: that is package delivery time is fixed and guaranteed because every PC is given to the token. No one PC can monopolies network.
- v. **No data collisions**.

Disadvantages of ring

1. A **single node failure** leads to the collapse of the full network.
2. **Unidirectional traffic** can be disadvantage in a simple ring. A break in the ring can disable the entire network; using dual ring can solve the weakness.
3. **Expansion** to the network can cause network disruption

Star topology

Physical star topology uses a central device or controller with drop cables extending in all direction. The devices are not directly linked to one another. Each network device is connected via point-to-point link to central device called '**HUB**' multipoint repeater or concentrator. The controller acts as an exchange: If one device wants to send data to another, it sends the data to the controller, which then relays the data to the other connected device.

When network expansion is expected and a greater reliability is expected then star topology is needed.

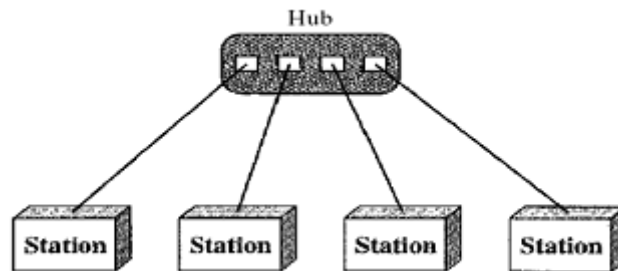

Working of star topology

Each PC on star network communicate with central hub that resends the message either to all the PC's (in a broadcast star network) or only to the destination PC (in a switched star network) when the communication between two nodes is to occur a complete circuit is dedicated to the connection for duration of call. The hub in a broadcast star network can be active or passive.

An active hub regenerates the electrical signal and sends it to all the computers connected to it. This type of hub is often called a multipoint repeater. Active hubs and switches require electrical power to run; **a passive hub** such as wiring panel or patch block merely at as a connection point and does not amplify or regenerate the signal. Passive hub doesn't require electrical power to run.

E.g.: - Ethernet to base t is a popular network based on star topology.

Advantages of star topology

There are several advantages to a star topology.

- i. Addition, Moving and deletion involves only one connection between that device and hub.
- ii. When the capacity of central hub is exceeded you can replace it with one that has larger number of ports to plug lines into new hub.
- iii. The center of the star network is a good place to diagnose network faults, intelligent hub (the hub with microprocessor) also provide for centralize monitoring and management of network.
- iv. Single PC failures do not necessarily bring down whole star network. The hubs can detect a network fall and isolate the defected PC or network cable and allow the rest of the network to continue operating.
- v. You can use several cable types in the same network with a hub that can accommodate multiple cable types.

Disadvantages of star topology

1. If the central hub fails the whole network fails to operate.
2. Many star networks requires a devices at the central point to rebroadcast or switched network traffic.
3. It **cost more to cable a star networks** because all the network cables must be pulled to one central point requiring more cable than other networking topologies.

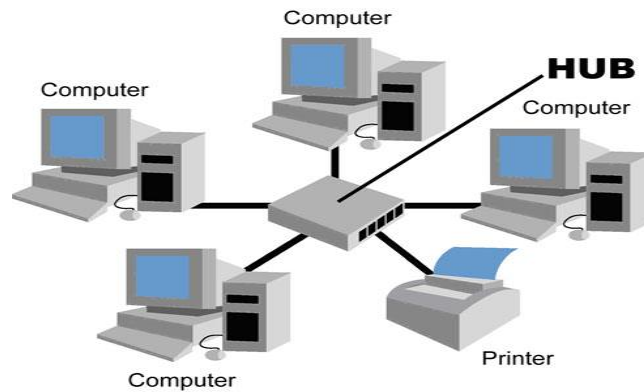

Mesh topology

In a mesh topology every device has dedicated point-to-point link to every other device. The term dedicated means that the link carries only between the two devices it connects. A fully connected mesh network has $n(n-1)/2$ physical connections to link devices.

To accommodate that many links every device on the network must have $(n-1)$ output ports because each device requires an interface for every other on the network. Mesh topology are not usually practical. In addition unless each station frequently sends signal to all the other stations and excessive amount of network bandwidth is wasted.

Mesh gets unmanageable beyond a very small number of devices. Most mesh topology networks are not true mesh networks.

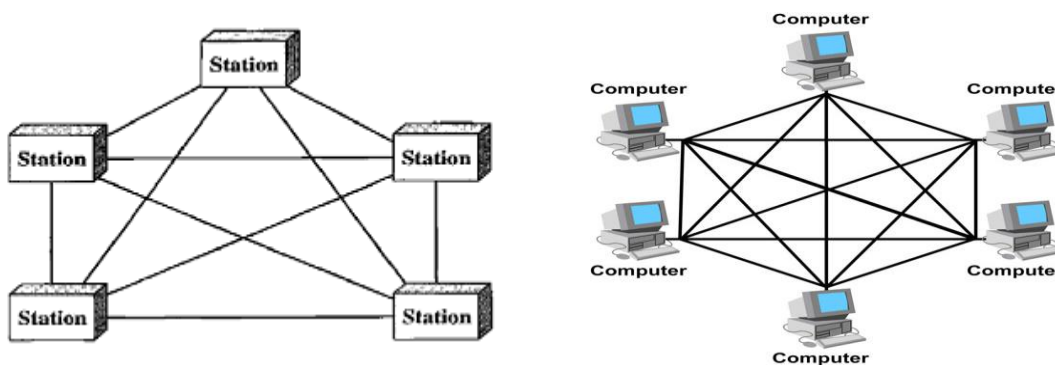

Mesh installation

Mesh topology N/w become more difficult to install as the no. of devices increases because of the sheer quantity of connections that must be made. A true mesh topology of seven devices would require 21 connections and six I/O ports.

Advantages:-

- The use of dedicated links guaranties that connections can carry its own data load. Thus **eliminating the traffic problem** that can occur when links must be shared by multiple devices.
- Mesh topology is **Robust** (strong) if one link becomes unusable. It doesn't incapacitate the entire n/w.
- Another advantage is **privacy and security** when every message sent travels along a dedicated line only the intended recipients sees it. Physical boundaries prevent other users from gaining access to message.
- Point to point link make **fault identification and fault isolation easy**. Traffic can be routed to avoid links with respected problems. This facility enables the n/w manager to discover the precise location of the fault and aids it finding its cause and solution.
- Extremely fault tolerant.
- It is **more reliable** compare to other topologies.
- In case of heavy traffic data can be routed around busy root.

Disadvantages

- As it involves a **lot of connection**. The total no. of physical links and the no. of I/O ports require to connect will be more and hence is prohibitively expensive.
- **Difficult to install and reconfigure** specially as no. of devices increases.
- Hardware required to connect each device is **highly expensive**.
- The sheer bulk of the wiring can be greater than the available space (walls, ceiling and floors) can accommodate. For these reasons a mesh topology is usually implemented in a limited fashion.

Hybrid Topology

A network can be hybrid. For example, we can have a main star topology with each branch connecting several stations in a bus topology as shown in Figure

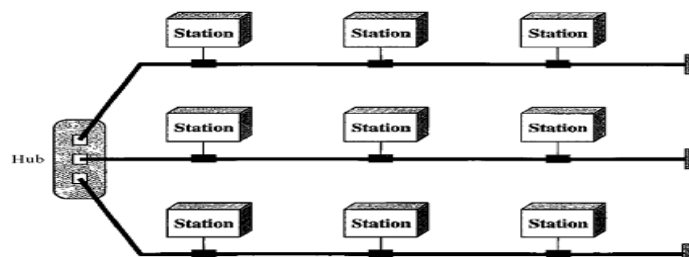

Star Bus (Tree Topology)



Star bus topology combines the bus and the star linking several stars hubs together with the bus trunk. If one computer fails, the hub can detect the fault and isolate the PC. If a hub fails PC connected to it will not be able to communicate and the bus n/w will be broken into two segments that can't reach each other.

Star ring

This is also called as star wired ring. The n/w cables are laid out much like a star n/w but a ring is implemented in the central hub outgoing hubs can be connected through the inner hubs effectively extending a loop of the ring. E.g. Token ring is considered a star ring although its topology is physical a star its function logically in a ring.

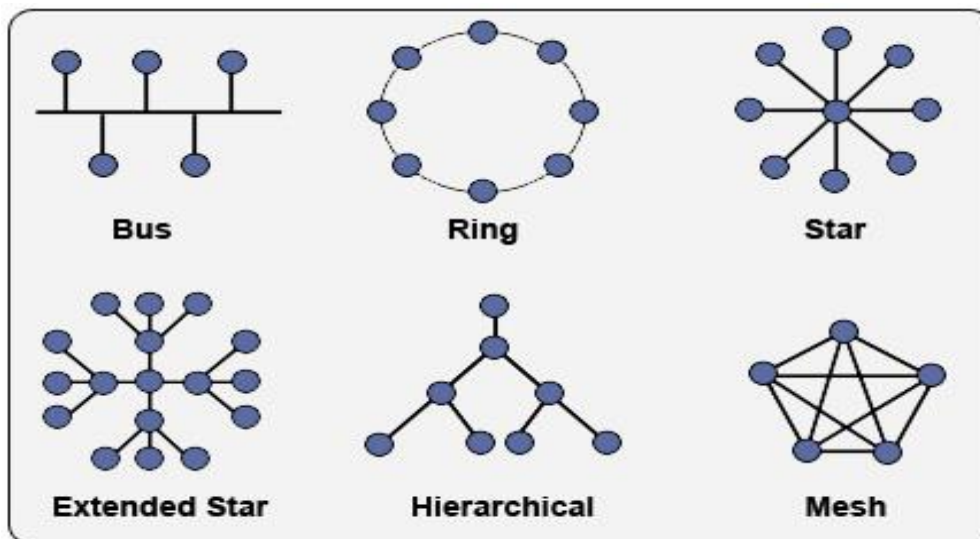
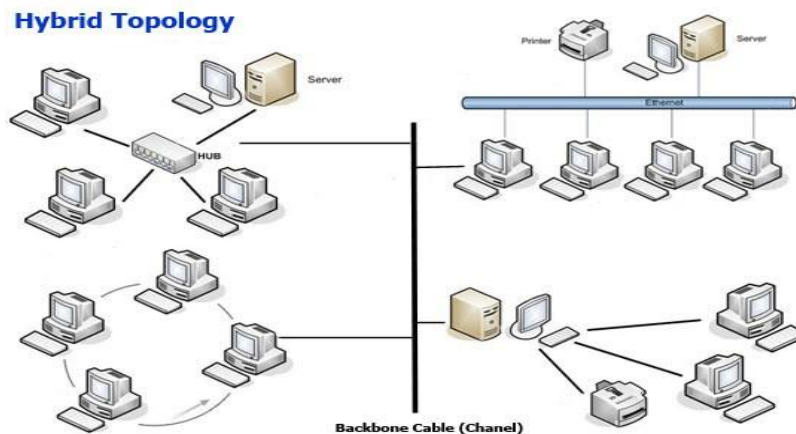

Question Bank:-

- What is topology?
- Describe
 1. Bus topology with diagram and state it's any two merits and demerits.
 2. Star topology with diagram and state it's any two merits and demerits.
 3. Ring topology with diagram and state it's any two merits and demerits.
 4. Mesh topology with diagram and state it's any two merits and demerits.

BTE.Q

- Describe n/w topology. Draw star topology.(4)
- State whether bus is active or passive n/w. Justify.(4)
- Compare bus with ring topology on the basis of cable use and fault tolerance.(4)
- State four adv. Of bus topology.(4)
- You are considering n/wing topologies for a n/w for a telemarketing firm under what circumstances would a ring be less appropriate than star.
- State any two merits of ring topology. Describe token. State whether ring topology is broadcast or point to point n/w?
- Describe n/w topology. Draw star, bus, topology connecting three star networks each star n/w consist of 4 Pc's.
- State any two adv. And disadvantage of star topology.
- State merits of bus topology. Explain the use of BNC barrel connector in bus topology.
- You are installing a new n/w for a company that is growing rapidly the current design calls for 40 computers with expansion to 100 in the next six months because of the speed at which the n/w is expected to grow. You want to make sure that trouble shooting will be easy as possible. Considering this factors which topology should be used in the new n/w. Justify your answer.
- State whether star is active or passive n/w. Justify? Give two advantages of star topology.

2.2 Network control devices

To expand a single network without breaking it into new pass or connecting it through another different network. All networks require devices to provide connectivity and functionality.

Purpose of Using Network Devices.

- Allow a greater number of nodes to be connected to the network.
- Extend the distance over which a network can extend.
- Localize traffic on the network.
- Can merge existing networks.
- Isolate network problems so that they can be diagnosed more easily.

Devices and the layers at which they operate

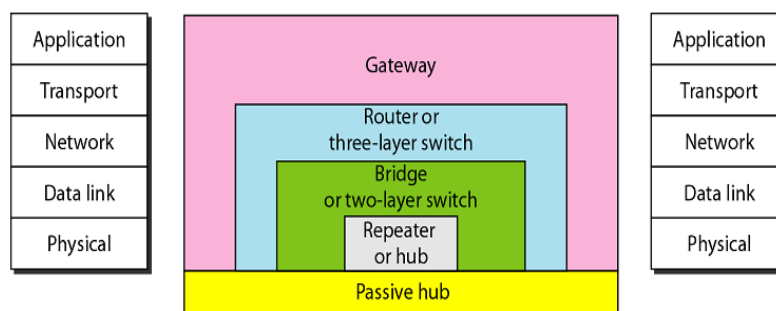

Five categories of connecting devices

You can usually use one of the following devices.

- Connectors
- Hubs
- Repeaters
- Bridges
- Switches
- Routers
- Modem, etc.

1. Connectors:

Que. List the different types of connector used in communication? State its uses.

- To connect **cable between two computers.**
- Connectors are of different type such as –
 1. **Twisted Pair cable**
 2. **Co-axial Cable**
 3. **Fibre optic cable.**
- Connectors are type such as-
 1. **Jacks**
 2. **Plugs**
 3. **Sockets and ports**

Example:

- RS232 and V35 for serial interface
- RJ45 and BNC connectors for Ethernet.
- SC or ST connectors for fibre optic

BNC Connector

(Bayonet Nut Coupling) A commonly used plug and socket for audio, video and networking applications that provides a tight connection. This connector has a center pin connected to the center cable conductor and a metal tube connected to the outer cable shield. A rotating ring outside the tube locks the cable to any female connector. BNCs are used to connect a variety of different coaxial cable types. After the plug is inserted, it is turned, causing pins in the socket to be pinched into a locking groove on the plug.



RJ-11 (Registered Jack)

Standard telephone cable connectors, **RJ-11** has 4 wires (and RJ-12 has 6 wires). **RJ-11** is the acronym for Registered Jack-11, a four- or six-wire connector primarily used to connect telephone equipment.

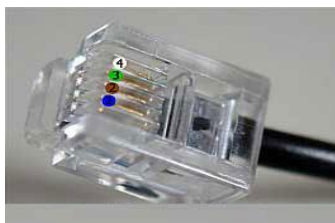

F-Type

The **F connector** is a type of RF connector commonly used for cable and universally for satellite television.



RJ-45 (Registered Jack)

The acronym for **Registered Jack-45** is RJ-45. The **RJ-45** connector is an eight-wire connector that is commonly used to connect computers to a local area network (LAN), particularly Ethernet LANs. Although they are slightly larger than the more commonly used **RJ-11** connectors, RJ-45s can be used to connect some types of telephone equipment.



ST (Straight Tip) and SC (Subscriber Connector or Standard Connector)

Fibre network segments always require two fibre cables: one for transmitting data, and one for receiving. Each end of a fibre cable is fitted with a plug that can be inserted into a network adapter, hub, or switch. In the North America, most cables use a square SC connector (Subscriber Connector or Standard Connector) that slides and locks into place when inserted into a node or connected to another fibre cable, Europeans use a round ST connector (Straight Tip) instead.



USB (Universal Serial Bus)

Universal Serial Bus, or USB, is a computer standard designed to eliminate the guesswork in connecting peripherals to a PC. It is expected to replace serial and parallel ports. A single USB port can be used to connect up to 127 peripheral devices, such as mice, modems, keyboards, digital camera's, printers, scanners, MP3 players and many more. USB also supports Plug-and-Play installation and hot plugging.



2. Repeaters

A repeater or regenerator is an electronic device that operates on only the physical layer of the OSI MODEL. Signal that carry information within a network can travel a fix distance before attenuation enlarges the integrity of data. A repeater installed on a link receives the signal before it becomes too weak, and put the refresh copy back on the link.

A repeater allows us extending only the physical length of a network. The repeater does not change the functionality of the network in any way. The two sections (segments) connected by the repeater in fig are in reality one network. The repeater doesn't have the intelligence to keep the frame from passing to the right side when it is meant for a station on the left. The difference is that with the repeater stations receives the true copy of the frame.

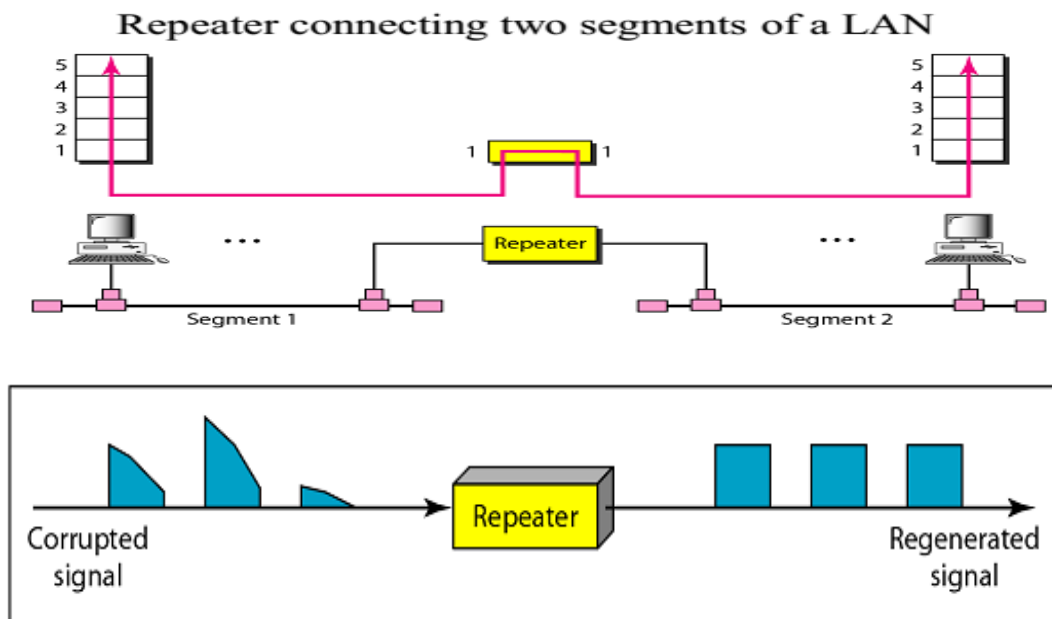

Repeater as not an amplifier

An amplifier can't discriminate between the intended signal and noise. It amplifies equally everything fed into it. A repeater doesn't amplify the signal. It regenerates it. When it receives a weak end or corrupted signal it creates a copy bit at the original strength.

The location of the repeater on a link is vital. A repeater must replace so that a signal reaches it before any noise changes the meaning of any of its bits. A little noise can alert the precision of a bits voltage with losing its identity.

Que: Describe repeater? State situations under which it is necessary in network?

- It connects two segments of the same network.
- Types of Single port, multi-port repeaters.

3. Hub

Que. What is hub? State how they are classified?

Networks using a Star topology require a central point for the devices to connect. Originally this device was called a concentrator since it consolidated the cable runs from all network devices. The basic form of concentrator is the hub.



As shown in Figure; the hub is a hardware device that contains multiple, independent ports that match the cable type of the network. Most common hubs interconnect Category 3 or 5 twisted-pair cable with RJ-45 ends, although Coax BNC and Fiber Optic BNC hubs also exist. The hub is considered the least common denominator in device concentrators. Hubs offer an inexpensive option for transporting data between devices, but hubs don't offer any form of intelligence. Hubs can be active or passive.

Important Points

- A hub is used as a **central device**.
- Connects the computers in **star topology**.
- **Hubs** are simple devices that **direct data packets to all devices connected to the hub**.
- Hubs regenerate and retime network signals
- **hubs work at the OSI physical layer**
- They **cannot filter** network traffic.
- They cannot determine best path
- They are really **multi-port repeaters**

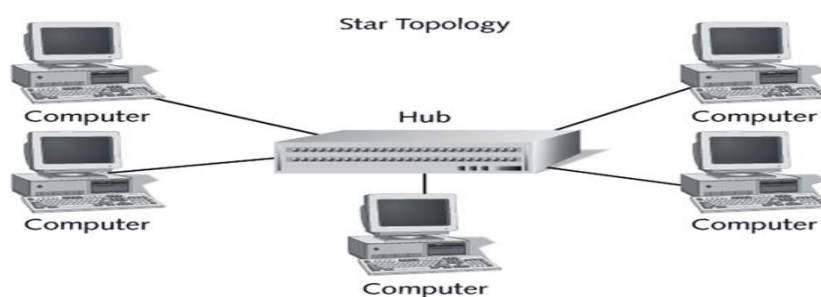

Fig. HUB

There are three main types of hub:

❖ **Passive hub**

A passive hub simply combines the signal of n/w segment. There is no signal processing or regeneration because it does not boost the signal and in fact absorbs some of the signal. A passive hub reduces by half the maximum, cabling distance permitted.

E.g. If a segment normally allows a reliable transmission distance of 100 meters, the distance between a passive hub and a device can be only 50m also with a passive HUB each pc can receive the signal send from all the other pc's connected to the **hub**.

❖ **Active hub**

These are like passive hub except that they have electronic component that regenerate or amplify signal. Because of this the distance between devices can be increased. The main drawback to some active hub, i.e. they amplify noise as well as signal depending on whether they function as simple amplifiers or as signal regenerators. They are also much more expensive than passive hubs function as repeaters (Create a duplicate copy of signal). They are sometimes called multi-port repeaters.

❖ **Intelligent hub**

In addition to signal regenerations these hubs perform some n/w management and intelligent path selection. A switching HUB chooses only the port of the device where the signal leads to go rather than sending the signal along all paths. Many switching hubs can choose which alternative path will be weakest and send the signal that way. One disadvantage to this is that you can permanently connect all transmission media segments because each segment will be used only when a signal is sent to device using that segment.

4. Bridges

A **bridge** is used to join two network segments together, it allows computers on either segment to access resources on the other. They can also be used to divide large networks into smaller segments. Bridges have all the features of repeaters, but can have more nodes, and since the network is divided, there is fewer computers competing for resources on each segment thus improving network performance.



Bridges can also connect networks that run at different speeds, different topologies, or different protocols. But they cannot, join an Ethernet segment with a Token Ring segment, because these use different networking standards. Bridges operate at both the **Physical Layer** and the MAC sub layer of the **Data Link layer**. Bridges read the MAC header of each frame to determine on which side of the bridge the destination device is located, the bridge then repeats the transmission to the segment where the device is located.

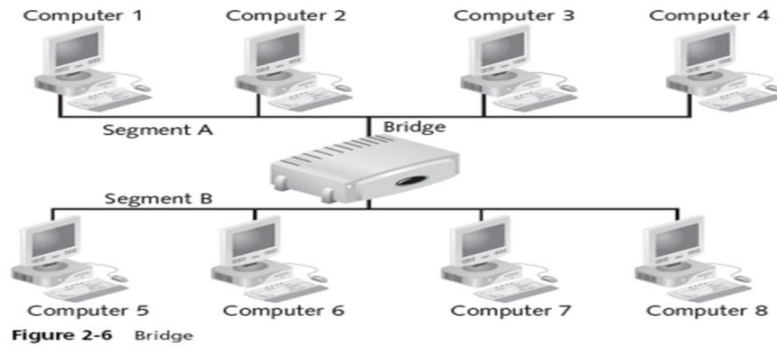
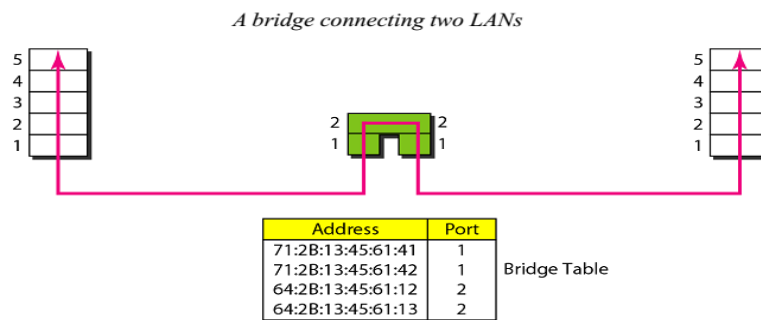

Fig. Bridge

Unlike the repeaters which simply passes on all the signals it receives a bridges selectively determines the appropriate segment to which it should pass a signal. It does this by reading the address of the entire signal it receives. The bridges read the physical location of the source and destination computers from the addresses and store it to a table.



The process works like this

- For learning bridges receives all signals from both the segments.
- The bridge reads the address and discards (filters) all signals from segment1 that are address to segment1 because they don't need to cross the bridge.

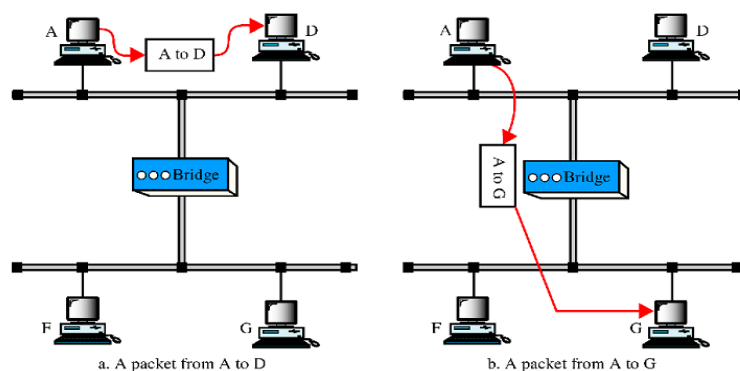

The figure shows the messages or signals which do not need to cross the bridge (Message from computer-A to Computer- D) and other half part shows the messages that needs to pass through the bridge (Message from computer-A to Computer-G). Bridges also provide security through this portioning of traffic.

There are basic two types of bridges.

➤ **Transparent bridges**

Keeps a table of addresses in memory to determination where to send the data.

- Also called **learning bridges**
- Build a table of MAC addresses as frames arrive.
- **Ethernet networks use transparent bridge**
- Duties are : **Filtering frames, forwarding and blocking**

➤ **Source routing bridge**

Requires the entire route to be included in the transmission and don't route packets intelligently. IBM token ring n/w uses this type of bridges. If a segment on n/w is been used only 60% then consider, using bridges will improve performance.

- Used in **Token Ring networks**
- Frame contains not only the **source and destination address** but also the **bridge addresses**.

Reasons to go for bridges

- To divide the big n/w like university.
- Organization may geographically spread over multiple buildings.
- To split an n/w logical.
- Single LAN is adequate (sufficient but physical distance is too great).
- For reliability bridges can be placed at critical nodes. To prevent a single node go out of order from bringing down the entire system. (E.g. bus topology)
- For security insert bridges at various places and being careful not to forward sensitive traffic.

Advantages of using a bridge

- Extend physical network
- Reduce network traffic with minor segmentation
- Reduce collisions
- Connect different architecture

Disadvantages of using bridges

- **Slower** than repeaters due to filtering
- **Do not filter broadcasts**
- **More expensive** than repeaters

Que- What is bridge? Describe its functioning? State types of bridges?

Que- Compare hub & repeater?