



WINTER – 14 EXAMINATION

Model Answer

Subject Code: 17213

Important Instructions to examiners:

- 1) The answers should be examined by key words and not as word-to-word as given in the model answer scheme.
- 2) The model answer and the answer written by candidate may vary but the examiner may try to assess the understanding level of the candidate.
- 3) The language errors such as grammatical, spelling errors should not be given more Importance (Not applicable for subject English and Communication Skills).
- 4) While assessing figures, examiner may give credit for principal components indicated in the figure. The figures drawn by candidate and model answer may vary. The examiner may give credit for any equivalent figure drawn.
- 5) Credits may be given step wise for numerical problems. In some cases, the assumed constant values may vary and there may be some difference in the candidate's answers and model answer.
- 6) In case of some questions credit may be given by judgement on part of examiner of relevant answer based on candidate's understanding.
- 7) For programming language papers, credit may be given to any other program based on equivalent concept.

1. Attempt Any Ten of the following:

(20 Marks)

a. Define active and passive components.

Ans. (Each definition – 1 Mark)

Active Component

The electrical components which are capable of amplifying or processing electrical signals are called active components. Example: Diode, Transistor etc.

Passive Component

The electrical components which are not capable of amplifying or processing electrical signals are called active components. Example: Inductor, Capacitor, Resistor etc.

b. Draw the symbol of N-channel and P-channel JFET.

Ans. (Correct symbols – 1 Mark each)

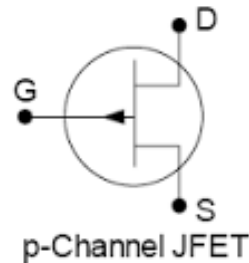
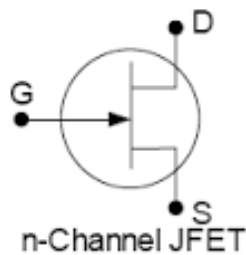

c. Give two applications of light emitting diode.

Ans. (Any two correct applications – 1 Mark each)

1. Infra-red LEDs are used in burglar alarm systems.
2. For solid state video displays which are rapidly replacing CRT.
3. An image sensing circuit for 'picture phones'
4. In array of different types for displaying alpha-numeric characters.

d. Define current gain and voltage gain of common emitter amplifier.

Ans. (Correct definitions – 1 Mark each)

Current Gain

Current Gain of CE amplifier is defined as the ratio of collector current (I_C) to the base current (I_B).

Voltage Gain

Voltage Gain of CE amplifier is defined as the ratio of output voltage (V_{CE}) to the input voltage (V_{BE}).

e. List four specifications of PN Junction Diode.

Ans. (Any 4 Correct specifications – 2 Marks)

The specifications of PN Junction Diode are:

1. Maximum reverse voltage (V)
2. Repetitive peak voltage (V)
3. Maximum forward current (mA)
4. Power dissipation.
5. Repetitive peak forward current.
6. Average forward current (A)
7. Surge current (A)
8. Operating ambient temperature ($^{\circ}\text{C}$)
9. Maximum junction temperature ($^{\circ}\text{C}$)
10. Forward voltage (V)

f. Give four advantages of IC's.

Ans. (Any 4 Correct advantages – 2 Marks)

1. The physical size of an IC is extremely small (generally thousand times smaller) than that of discrete circuits.
2. The weight of an IC is very less as compared to that of equivalent discrete circuits.
3. The reduction in power consumption is achieved due to extremely small size of IC.
4. Interconnection errors are non-existent in practice.
5. Temperature differences between components of a circuit are small.
6. Close matching of components and temperature coefficients is possible.
7. In case of circuit failure, it is very easy to replace an IC by a new one.
8. Active devices can be generously used as they are cheaper than passive components.

g. Draw the circuit diagram of CLC filter.

Ans. (Any Relevant Correct diagram – 2 Marks)

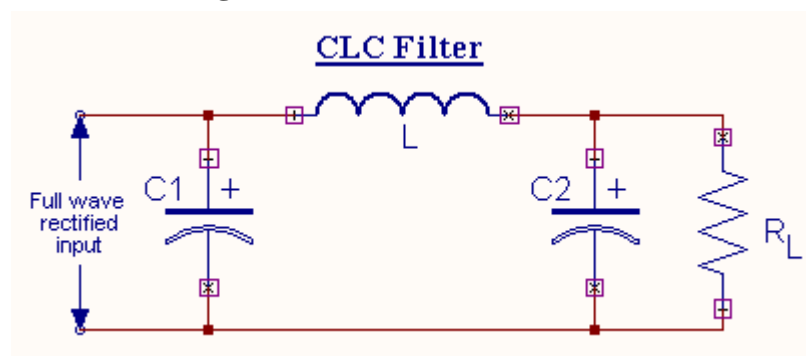

h. Define transconductance (g_m) and amplification factor (μ) for a JFET.

Ans. (Correct definitions – 1 Mark each)

Transconductance

Transconductance is defined as the ratio of change in Drain current (ΔI_D) to change in Gate to Source Voltage (ΔV_{GS}) at a constant V_{DS} .

Amplification Factor

Amplification Factor is defined as the ratio of change in Drain to Source Voltage (ΔV_{DS}) to change in Gate to Source Voltage (ΔV_{GS}) at a constant I_D .

i. Draw the symbol of zener diode and tunnel diode.

Ans. (Zener diode – 1 Mark and Tunnel diode – 1 Mark)

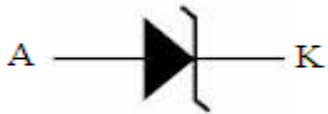

Symbol of a Zener Diode

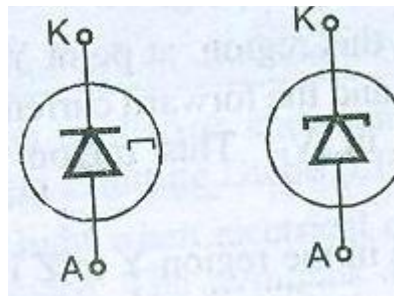

Symbols of tunnel diode

j. Give four applications of analog IC's.

Ans. (Any Four Correct Applications – 2 Marks)

Analog IC's are used in:

1. Aircrafts
2. Space Vehicles
3. RADAR
4. Communication Systems
5. Radio

k. Draw the symbol of NPN and PNP transistor.

Ans. (Each correct symbol – 1 Mark)

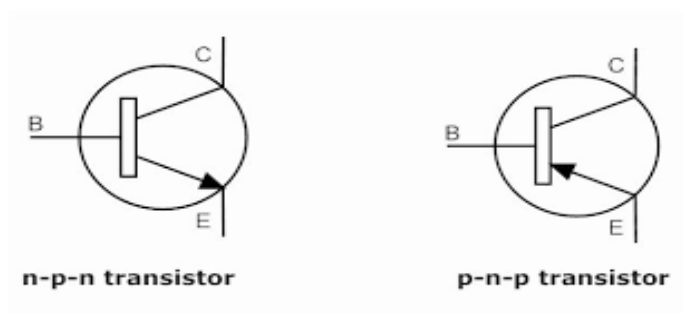

1. Draw the symbol of variable resistor and electrolytic capacitor.

Ans. (Each correct symbol – 1 Mark)



2. Attempt any four of the following:

(16 Marks)

a. Give four applications of electronics in medical field.

Ans. (Any Four Correct Applications – 4 Marks)

1. Electro cardiograph (ECG): It is used to find the condition of the heart of a patient.
2. X-Ray Machine: It is used for taking pictures of internal bone structures.
3. Ultra Sound Scanner: It is used to take pictures and examine the functions of Brain, Kidney etc.
4. Electrical Encephalograph (EEG): It is used for neurological investigations.
5. Cathode Ray Oscilloscope: It is used for studying muscle actions within the body.
6. Magnetic Resonance Imaging: It is used for investigating tumors in brain or other parts of body.

b. Explain the working principle of varactor diode.

Ans. (Diagram 2 Marks, Principle – 2 Marks)

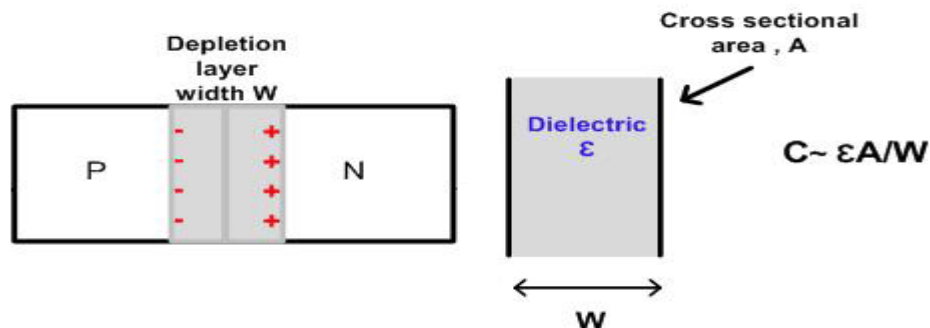

Working principle:

The varactor or varicap is a diode that exhibits the characteristics of a variable capacitor. The depletion region at the $p-n$ junction acts as the dielectric and plates of a common capacitor and is caused to expand and contract by the voltage applied to the diode. This action increases and decreases the capacitance. The schematic symbol for the varactor is shown beside. Varactor diodes are used in tuning circuits and can be used as high-frequency amplifiers.

c. Explain the working of PNP transistor with the help of constructional diagram.

Ans. (Diagram – 2 Marks, Explanation – 2 Marks)

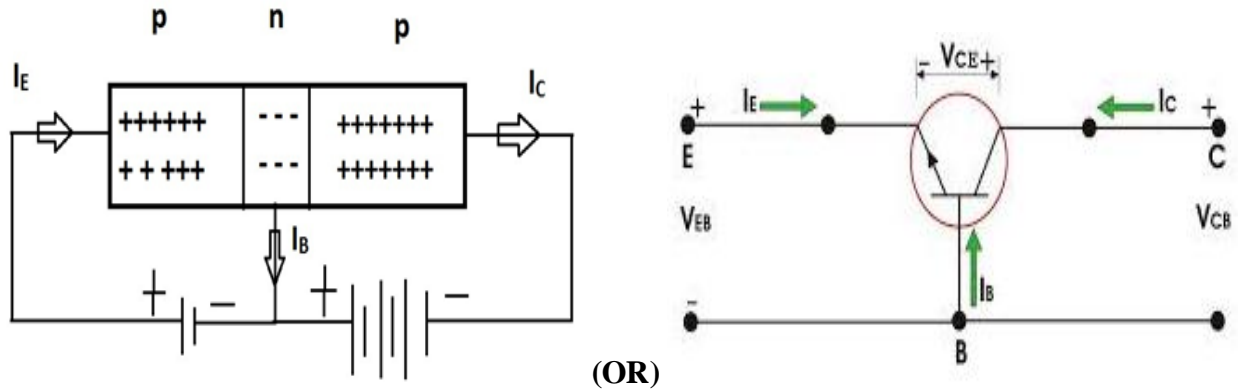

Working

- 1) Base emitter junction is forward biased and base collector is reverse biased.
- 2) The emitter is common and base is the input terminal, collector is the output terminal.
- 3) $I_E = I_B + I_C$ basic equation of transistor.
- 4) The holes from emitter are repelled and they move towards the base. Base is lightly doped and they get attracted by collector which is reverse biased.
- 5) The current gain for CE mode is $\beta = I_C / I_B$

d. Explain the working of single stage CE amplifier with the help of circuit diagram.

Ans. (Diagram – 2 Marks, Working – 2 Marks)

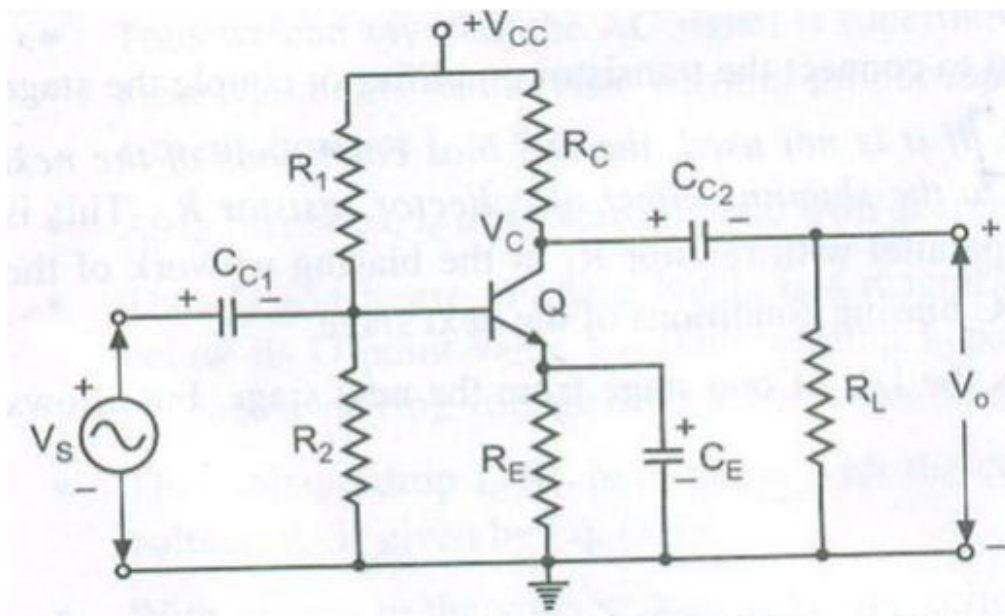

Working

1. The circuit diagram of a voltage amplifier using single transistor in CE configuration is shown in figure. It is also known as a small-signal single-stage CE amplifier or RC coupled CE amplifier. It is also known as a voltage amplifier.
 2. The potential divider biasing is provided by resistors R_1 , R_2 and R_E .
 3. It provides good stabilization of the operating point. The capacitors C_{C1} and C_{C2} are called the coupling capacitors used to block the AC voltage signals at the input and the output sides.
 4. The capacitor C_E works as a bypass capacitor. It bypasses all the AC currents from the emitter to the ground and avoids the negative current feedback. It increases the output AC voltage.
 5. The resistance R_L represents the resistance of whatever is connected at the output. It may be load resistance or input resistance of the next stage.
- e. Draw the experimental setup for obtaining the reverse characteristics of a zener diode and draw its V-I Characteristics for the same.

Ans. (Circuit Diagram – 2 Marks, V – I Characteristics – 2 Marks)

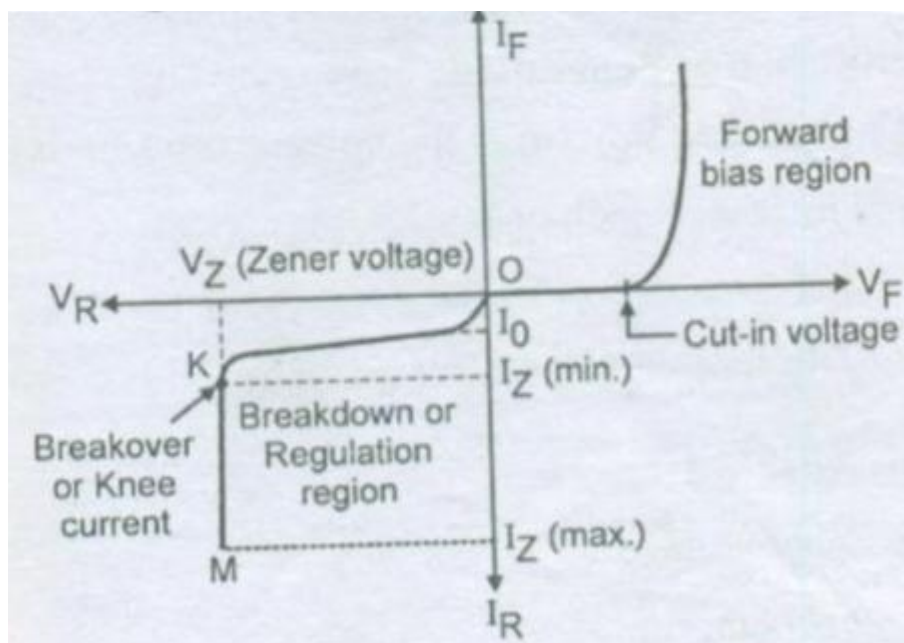
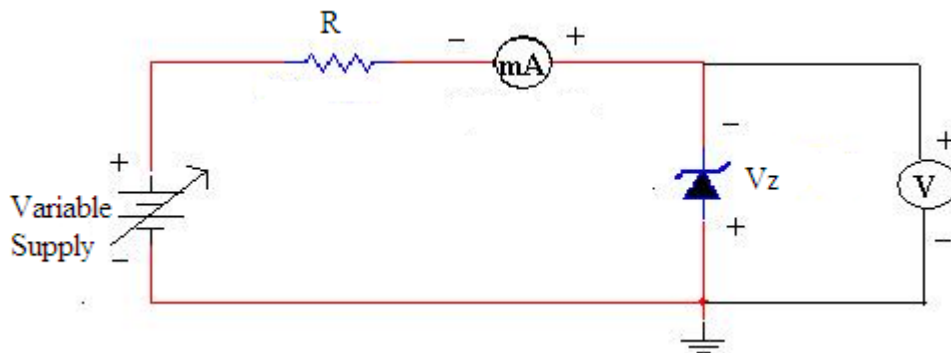

f. A crystal oscillator has $L = 0.33 \text{ H}$ and $C = 0.065 \text{ pF}$. Find the series resonant frequency.

Ans. (Formula – 1 Mark, Steps – 2 Marks, Final Answer – 1 Mark)

Given: $L = 0.33 \text{ H}$

$$C = 0.065 \text{ pF}$$

To Find: Series Resonant Frequency (f)

$$\text{Formula: } f_0 = \frac{1}{2\pi\sqrt{LC}}$$

Solution:

$$f_0 = \frac{1}{2\pi\sqrt{LC}} = \frac{1}{2\pi\sqrt{0.33 \times 0.065 \times 10^{-12}}} = 1.08 \text{ MHz}$$

Therefore, Series resonant Frequency $f_0 = 1.08 \text{ MHz}$

Q.3 Attempt any FOUR of the following

(16 Marks)

a) Compare VDR and LDR on the basis of working principle and characteristics.

Ans. (Working Principle – 2 Marks, Characteristics – 2 Marks)

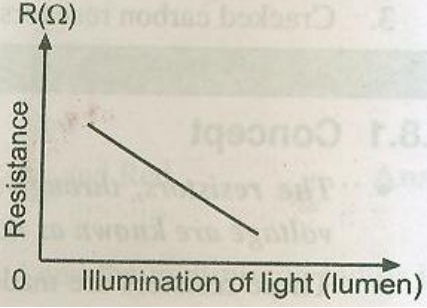
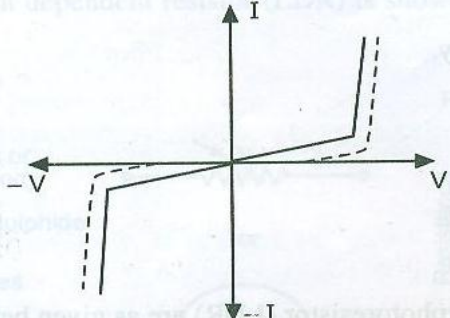
Sr.No	Parameter	VDR	LDR
1	Working Principle	The variation in voltage is reflected through an appreciable change in resistance. The resistance of VDR decreases.	The resistance depends on the intensity of light, as resistance decreases with increase in light intensity.
2	Characteristics		

b) Explain the operating principle and characteristics of LED.

Ans. (Operating principle – 2 Marks, Characteristics – 2 Marks)

Operating Principle

When the LED is forward biased, the electrons in the n-region will cross the junction and recombine with the holes in the p-type material.

When the recombination takes place, these electrons return back to the valence band which is at a lower energy level than the conduction band.

While returning back, the recombining electrons give away the excess energy in the form of light as shown below. This process is called as electroluminescence.

In this way an LED emits light. This is the principle of operation of LED.

Characteristics

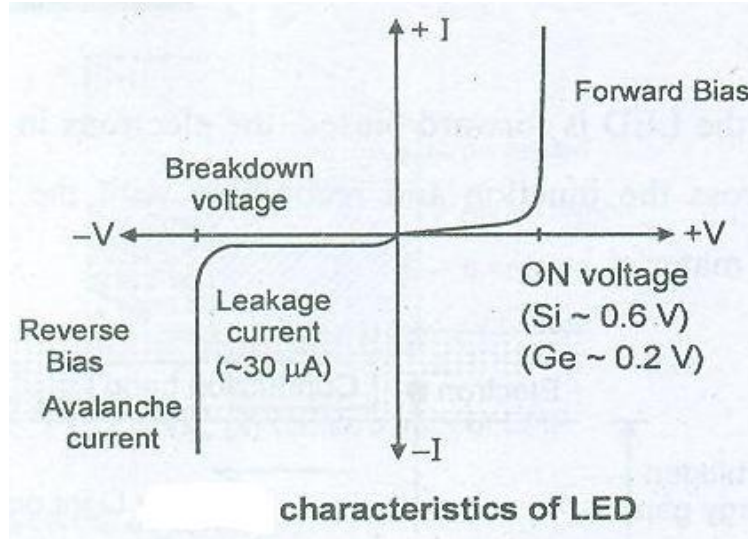

c) Draw the construction of P-channel JFET and explain formation of depletion layer.

Ans.

Construction (1 Mark)

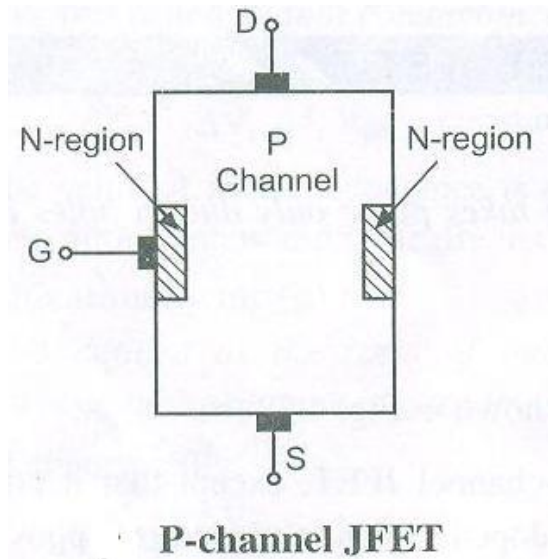

(OR)

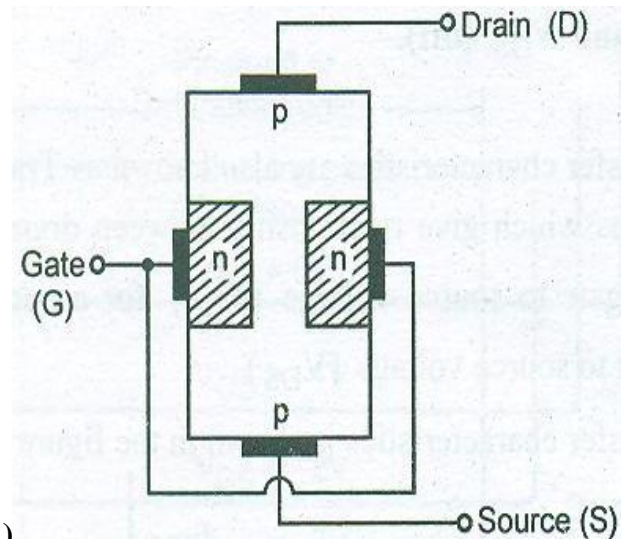

Formation of Depletion Region (1 Mark)

In P-type materials the polarities of V_{GG} , V_{GS} , V_{DD} , and V_{DS} are exactly opposite to those for the N-channel device. The direction of drain current is also reversed.

The drain current flows due to the majority carriers i.e. holes.

The drain current increases with an increase in the negative V_{DS} voltage.

The gate to source voltage V_{GS} is positive and the drain current decreases with increase in the positive V_{GS} voltage due to reduction in channel width.

Depletion Layer Formation Diagram (2 Marks)

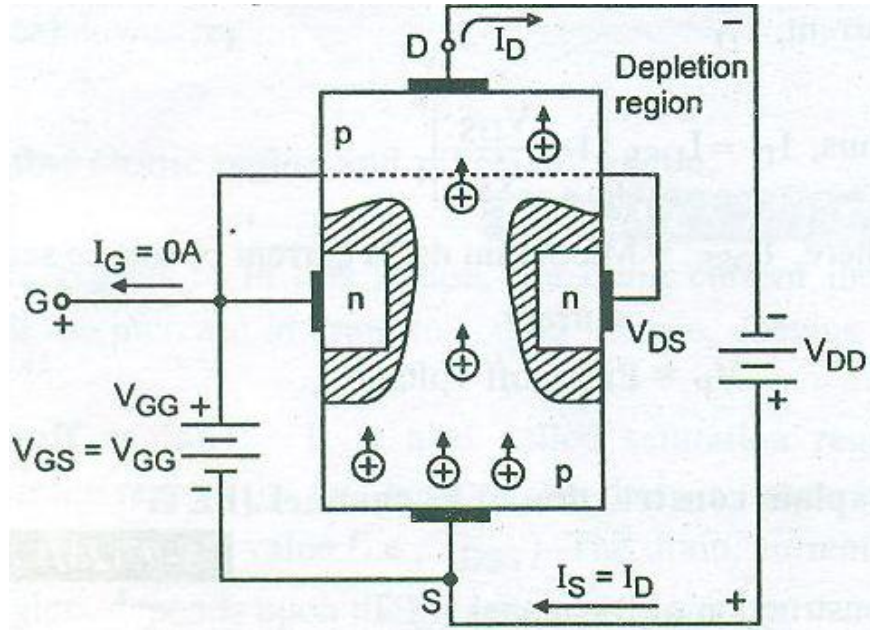

d) Compare CE and CB configuration on the basis of:

- | | |
|----------------------|-------------------|
| i. Input Impedance | iii. Current Gain |
| ii. Output Impedance | iv. Voltage Gain |

Ans. (Each correct point – 1 Mark)

Parameters	CB	CE
Input Impedance	Low (20Ω)	Medium (1kΩ)
Output Impedance	Very High (1MΩ)	Medium (40kΩ)
Current Gain	Nearly One	High
Voltage Gain	High	Higher than CB

e) A transistor has $I_B = 105\mu A$ and $I_C = 2.05mA$. Find β and α of the transistor.

Ans. (Formula – 1 Mark each, Correct β and α – 1 Marks Each)

Given: $I_B = 105\mu A$

$I_C = 2.05mA$

To find: β and α of the transistor

Formula: $\beta = \frac{I_C}{I_B}$ and $\alpha = \frac{\beta}{1+\beta}$

Solution:

$$\beta = \frac{I_C}{I_B} = \frac{2.05 \times 10^{-3}}{105 \times 10^{-6}} = 19.52$$

$$\alpha = \frac{\beta}{1+\beta} = \frac{19.52}{1+19.52} = 0.95$$

Hence, $\beta = 19.52$ and $\alpha = 0.95$

f) Draw the circuit diagram of crystal oscillator & write the expression for frequency of oscillation.

Ans. (Circuit Diagram – 2 Marks, Expression – 2 Marks)

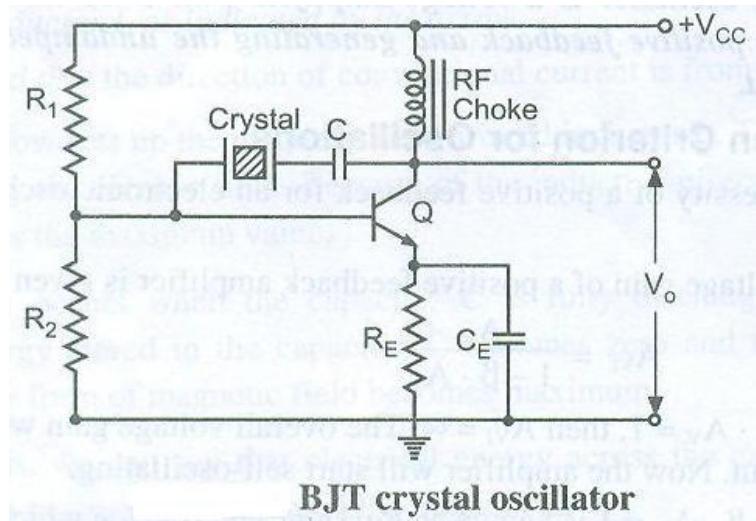

The frequency of oscillation of Crystal oscillator is given by, $f_0 = \frac{1}{2\pi\sqrt{LC}}$.

Q.4 Attempt any FOUR of the following

(16 Marks)

a) Give four applications of Schottky Diode.

Ans. (Any 4 Correct Applications – 1 Mark each)

Applications of Schottky Diode

1. Switching Mode Power Supply (SMPS)
2. AC to DC Converter
3. Radar System
4. Schottky TTL logic for computer
5. Mixers and detectors in communication equipment.

b) State the need of rectification.

Ans. (Correct explanation – 4 Marks)

1. Every electronic circuit such as amplifiers needs a dc power source for its operation.
2. This dc voltage has to be obtained from the ac supply.
3. For this the ac supply has to be reduced (stepped down) first using a step down transformer and then converted to dc by using rectifier.

c) State the advantages of FET over BJT (any four points).

Ans. (1 Mark for each any four correct points)

Advantages of FET over BJT

1. It has very high input impedance
2. Noise is reduced
3. It has smaller size, longer life and high efficiency
4. It has high power gain
5. As it has a negative temperature coefficient of resistance, it avoids the risk of thermal runaway.
6. Frequency response is excellent
7. It has large bandwidth.

d) Draw and explain the working of choke input or LC filter.

Ans. (Any relevant Circuit – 2 Marks, Working – 2 Marks)

Note: Circuit without rectifier should also be considered

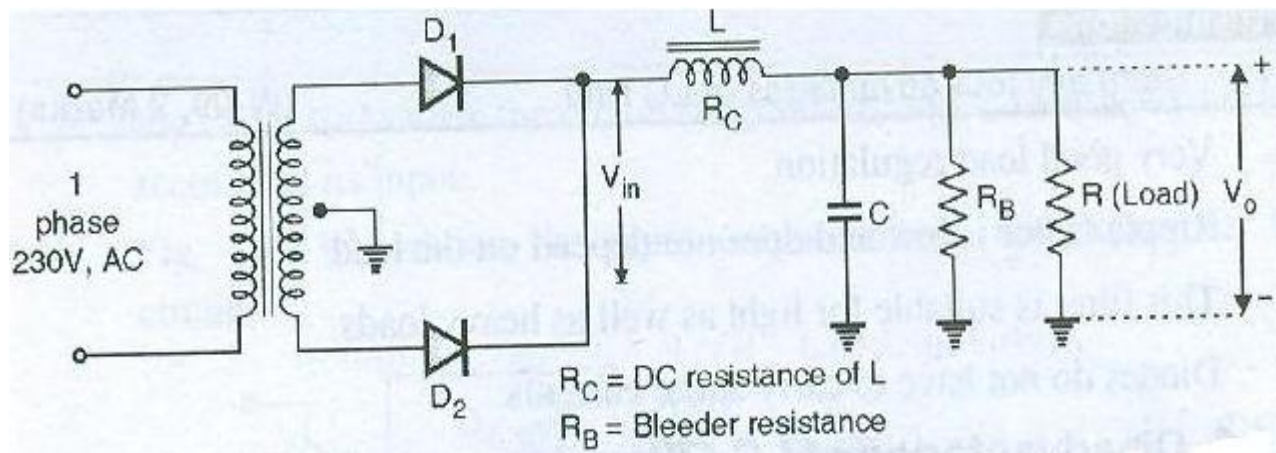

Working

- The combination of series inductor (L) filter on shunt capacitor (C) filter is known as LC filter.
- This filter is also known as the rectifier is applied across the input terminals of the choke input filter.
- The pulsating output of the rectifier contains AC as well as DC component of current. The choke L passes the DC component from the rectifier because its DC resistance R is very small.
- It opposes the AC component capacitor C bypasses AC component that presents at the output of inductor L but prevents DC component to flow through it.
- Therefore only DC component reaches to the load resistor RL.

e) Draw the frequency response curve of single stage RC coupled amplifier. Explain its behavior at low frequencies and high frequencies. (i.e. below 50 Hz and above 20 KHz respectively)

Ans. (Frequency Response – 2 Marks, Explanation – 2 Marks)

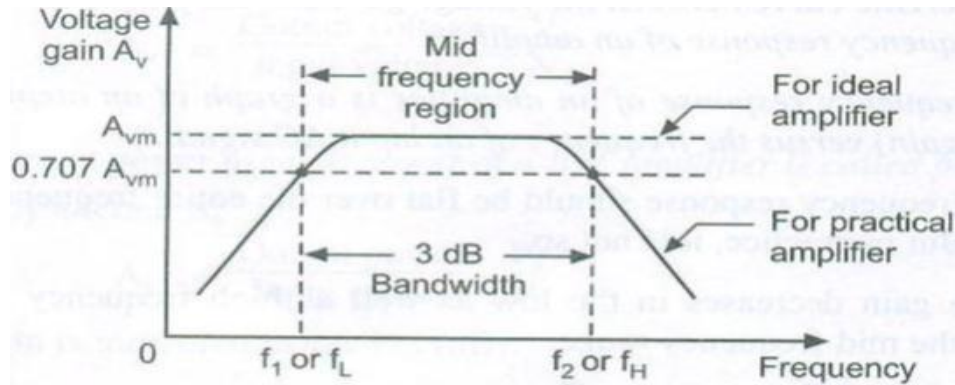

Explanation

Low frequency region: In low frequency region, the voltage gain (or output voltage) decreases with the decrease in frequency of an input AC signal due to the increased reactance of the coupling and bypass capacitors.

High frequency region: In high frequency region, the voltage gain (or output voltage) decreases with the increase in frequency of an input AC signal due to the BJT internal capacitances and stray capacitance.

f) Draw the circuit diagram of transformer coupled amplifier and its frequency response.

Ans. (Circuit Diagram – 2 Marks, Frequency Response – 2 Marks)

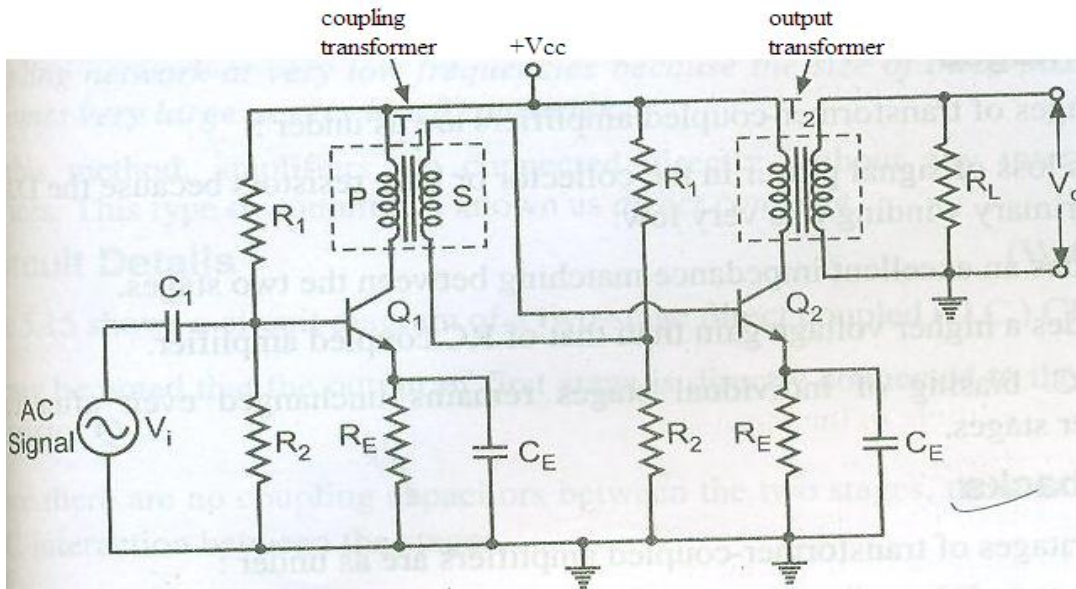

Frequency Response of Transformer Coupled Amplifier

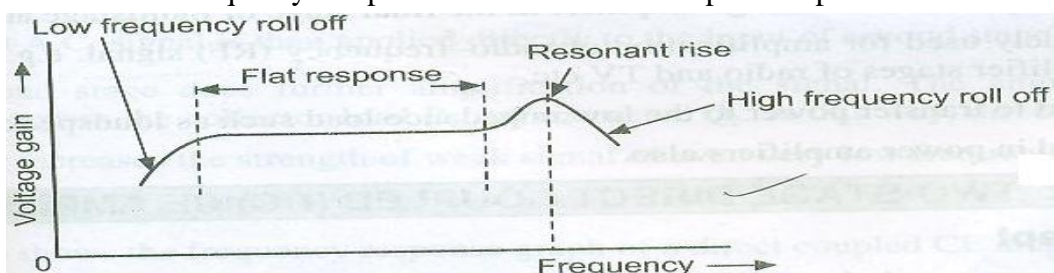

5. Attempt any FOUR of the following:

16 Marks

a. Explain the operating principle of PN junction diode under forward bias condition.

Ans. (Diagram – 2 Marks, Principle – 2 Marks)

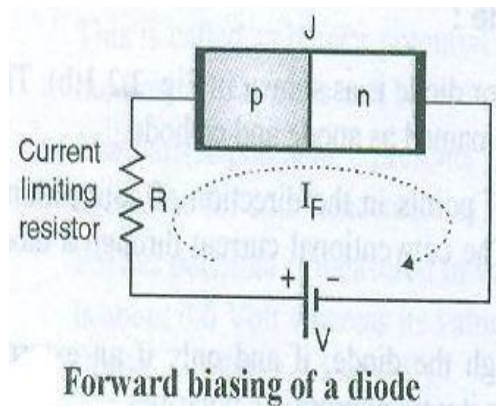

(OR)

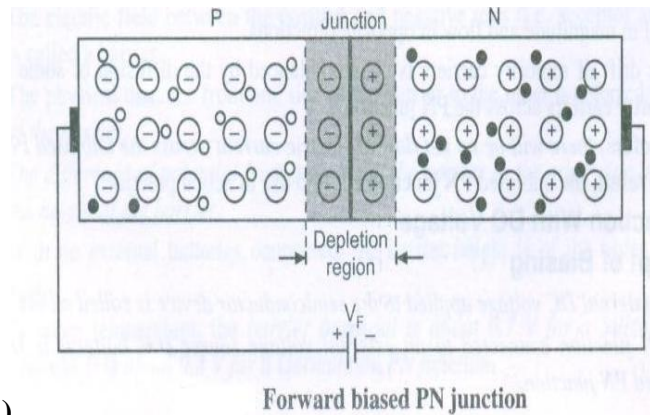

Principle

- If the p-region (anode) is connected to the positive terminal of the external DC source and n-side (cathode) is connected to the negative terminal of the DC source then the biasing is said to be “forward biasing”.
- Due to the negative terminal of external source connected to the n-region, free electrons from n-side are pushed towards the p-side. Similarly the positive end of the supply will push holes from p-side towards the n-side.
- With increase in the external supply voltage V , more and more number of holes (p-side) and electrons (n-side) start travelling towards the junction as shown in figure.
- The holes will start converting the negative ions into neutral atoms and the electrons will convert the positive ions into neutral atoms. As a result of this, the width of depletion region will reduce.
- Due to reduction in the depletion region width, the barrier potential will also reduce. Eventually at a particular value of V the depletion region will collapse. Now there is absolutely no opposition to the flow of electrons and holes.
- Hence a large number of electrons and holes (majority carriers) can cross the junction under the influence of externally connected DC voltage.

b. State four advantages of centre tapped full wave rectifier over half wave rectifier.

Ans. (4 advantages - 1 Mark Each)

1. The DC output voltage and load current values of full wave rectifier are twice than those of half wave rectifier.
2. The ripple factor is much less (0.482) than that of half wave rectifier (1.21).
3. The efficiency of full wave rectifier is twice (81.2%) than that of half wave rectifier (40.6%).
4. The TUF of full wave rectifier is more than that of half wave rectifier.

c. Draw the experimental setup to plot input and output characteristics of CE configuration and label them.

Ans. (Circuit Diagram – 2 Marks, Labeling – 2 Marks)

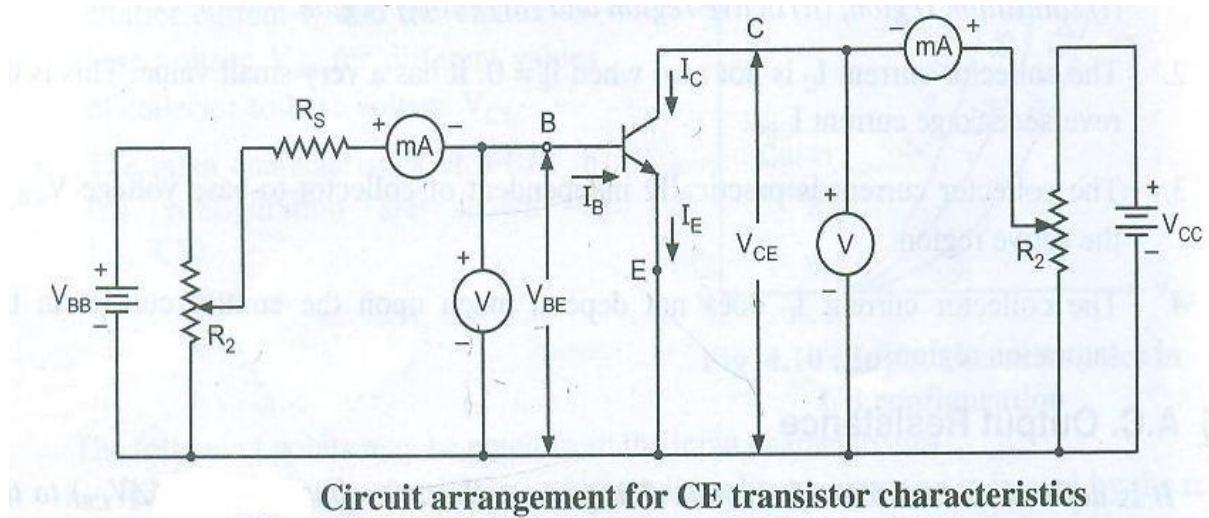

d. Draw the circuit diagram of bistable multivibrator using transistor and explain its working.

Ans. (Correct Diagram – 2 Marks, Working – 2 Marks)

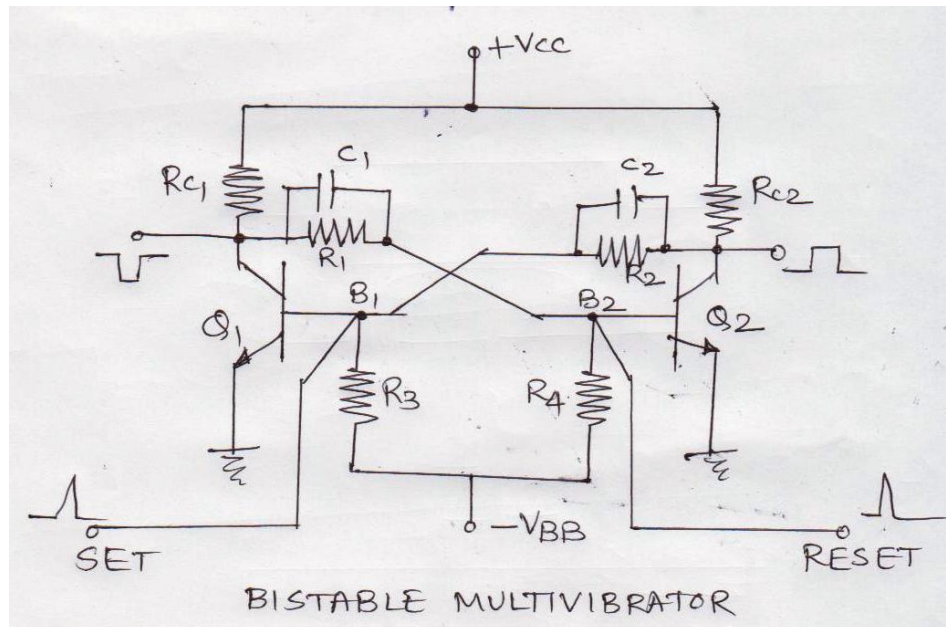

Working

1. When V_{CC} supply is switched ON one of the transistor will start conducting more than the other then because of feedback action, this transistor will be driven into saturation and the other to cut-off.
2. Assume that Q_1 is ON and Q_2 is OFF. It is a stable state of circuit.
3. A negative pulse applied to set input will turn OFF the transistor Q_1 and Q_2 switches ON.
4. Suppose positive pulse is applied at the reset input. It will cause Q_2 to conduct. As Q_2 conducts its collector voltage falls and it cut-offs Q_1 . This Q_1 is OFF and Q_2 is ON.
5. Now if positive pulse is applied at the set input, it will switch the circuit back to its original stable state i.e. Q_1 is ON and Q_2 is OFF.

e. List two advantages and two disadvantages of direct coupled amplifier over RC coupled amplifier.

Ans. (Any 2 Correct points – 2 Marks each)

Two Advantages of Direct Coupled Amplifier over RC Coupled Amplifier:

1. The impedance matching is good.
2. Frequency response is good for low frequency.
3. Space and weight is less.
4. Cost is less.

Two Disadvantages of Direct Coupled Amplifier over RC Coupled Amplifier:

1. Frequency response is poor in audio range.
2. It cannot amplify high frequency signal.
3. It has poor temperature stability.

f. Draw and describe zener diode voltage regulator.

Ans. (Correct Diagram- 2 Marks, description – 2 Marks)

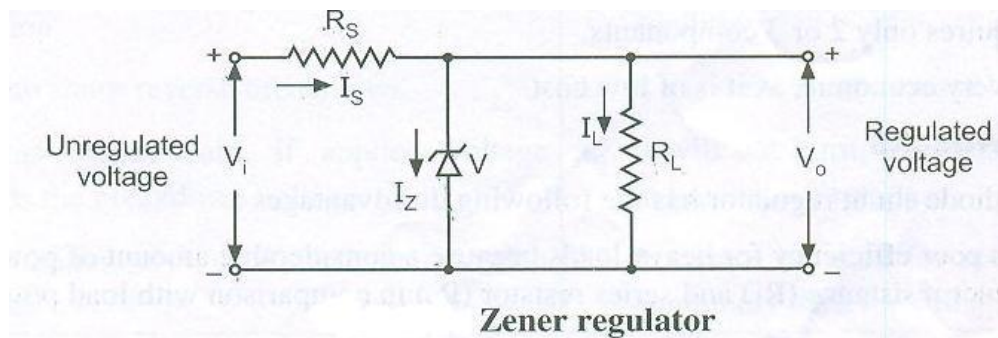

Working

- For proper operation, the input voltage V_i must be greater than the Zener voltage V_z . This ensures that the Zener diode operates in the reverse breakdown condition. The unregulated input voltage V_i is applied to the Zener diode.
- Suppose this input voltage exceeds the Zener voltage. This voltage operates the Zener diode in reverse breakdown region and maintains a constant voltage, i.e. $V_z = V_o$ across the load inspite of input AC voltage fluctuations or load current variations. The input current is given by, $I_S = V_i - V_z / R_s = V_i - V_o / R_s$
- We know that the input current I_S is the sum of Zener current I_z and load current I_L .
Therefore, $I_S = I_z + I_L$
or $I_z = I_S - I_L$
- As the load current increase, the Zener current decreases so that the input current remains constant. According to Kirchhoff's voltage law, the output voltage is given by,
 $V_o = V_i - I_S \cdot R_s$
- As the input current is constant, the output voltage remains constant (i.e. unaltered or unchanged). The reverse would be true, if the load current decreases. This circuit is also correct for the changes in input voltage.
- As the input voltage increases, more Zener current will flow through the Zener diode. This increases the input voltage I_S , and also the voltage drop across the resistor R_s , but the load voltage V_o would remain constant. The reverse would be true, if the decrease in input voltage is not below Zener voltage.



- Thus, a Zener diode acts as a voltage regulator and the fixed voltage is maintained across the load resistor RL.

6. Attempt any four of the following: (16 Marks)

a. Define the following terms with respect to PN junction diode:

- i. Static Resistance
- ii. Dynamic Resistance

Ans. (Correct definition – 2 Marks each)

Definition of static resistance:

The resistance of a diode at the operating point can be obtained by taking the ratio of V_F and I_F . The resistance offered by the diode to the forward DC operating conditions is called as “DC or static resistance”.

Definition of Dynamic resistance:

The resistance offered by a diode to the AC operating conditions is known as the “Dynamic Resistance”.

b. What is a voltage regulator? State the necessity of voltage regulator.

Ans. (Voltage Regulator – 2 Marks, Necessity – 2 Marks)

Voltage Regulator is a circuit which will try to maintain the output voltage constant under all the operating circumstances. The output voltage will not change though there is a change in input voltage. The voltage regulator is the last block in the d.c regulated power supply.

Need of Voltage Regulator

- The expensive electronic instruments cannot use the unregulated dc power supply because the output contains ripples and its content in output will increase with increase in load current.
- Hence, the output voltage also does not remain constant.
- So to get a constant output voltage inspite of changes in input voltage, temperature, load current we need the voltage regulator.

c. State the need of biasing for transistor. Draw the circuit diagram of voltage divider biasing.

Ans. (Need of biasing – 2 Marks, Circuit diagram – 2 Marks)

Need of Biasing for Transistor: (any four)

1. The transistor should be biased in the active region if it is to be used for amplification and in saturation and cut off if it is used as a switch.
2. The Q point should be adjusted approximately at the center of the load line for voltage amplifier application.
3. The value of stability factor (S) should be as small as possible.
4. Q point should be stabilized by introducing a negative feedback in the biasing circuit.
5. The Q-point should not be affected due to temperature changes or device to device variation.
6. Bypass capacitor should be included to avoid reduction in voltage gain due to negative feedback.
7. Transistor should be biased in the linear region of the transfer characteristics.

Circuit

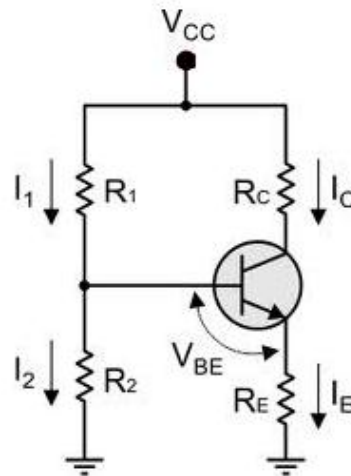

d. Write two applications of astable multivibrator and two application of bistable multivibrator.

Ans. (any 2 relevant applications – 2 mark each)

Two applications of astable multivibrator:

1. It is used in square wave generator.
2. It is used for voltage to frequency converters.
3. In ramp generator.
4. In flasher circuit.

Two applications of bistable multivibrator:

1. It is used as a memory element in computer logic circuit.
2. It is used as a memory element in shift registers.
3. It is used as a memory element in counters.

e. Draw the drain characteristics of JFET and show the different regions on it.

Ans. (Correct Diagram with labeling of regions – 4 Marks)

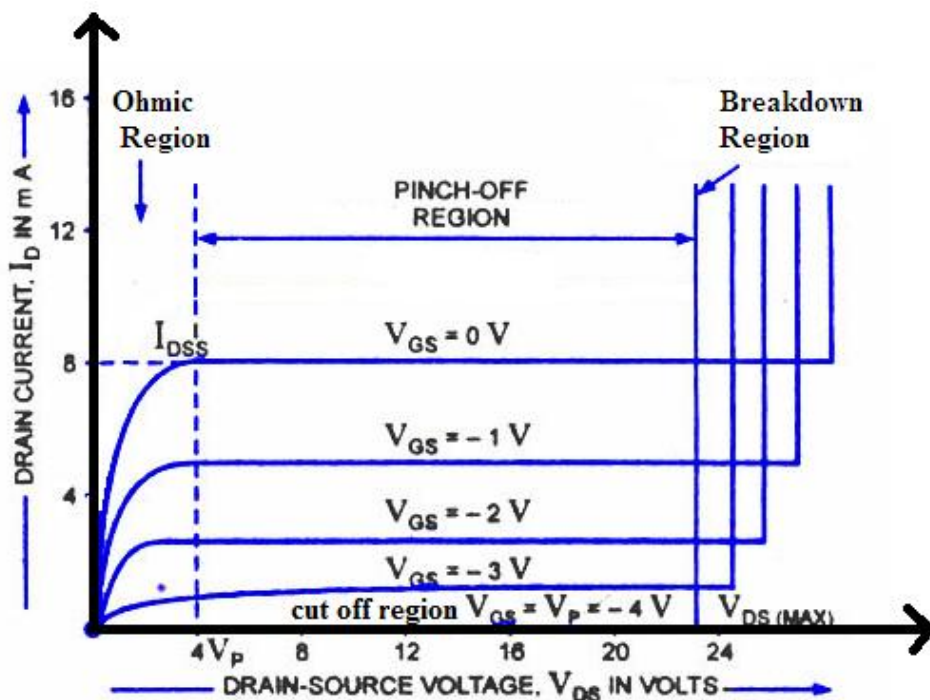

(OR)

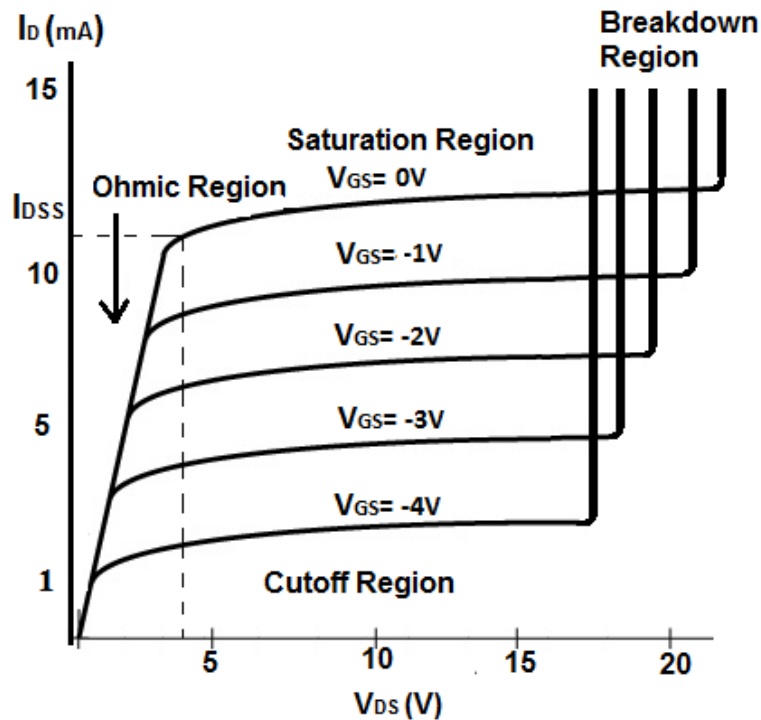

f. Following figure shows a centre tapped full wave rectifier circuit. Assuming both diodes to be ideal determine:

1. DC output voltage (V_{dc})
2. Peak Inverse Voltage (PIV) of diode

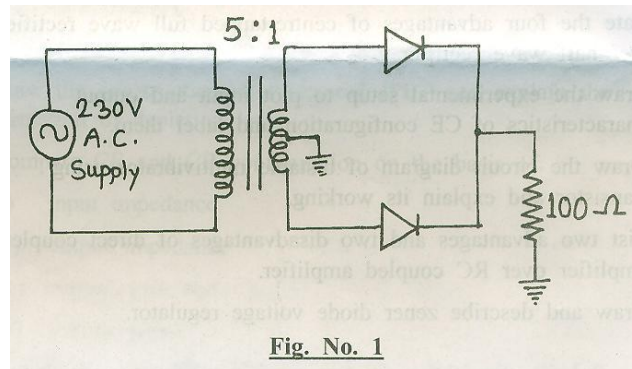

Ans.

Given: $V_1 = 230V$

$$\frac{N_2}{N_1} = \frac{N_2}{N_1}$$

½ Mark

1. We know that the secondary voltage

$$V_2 = \frac{N_2}{N_1} \times V_1 = 230 \times \frac{1}{5} = 46 \text{ volts}$$

1 Mark

Maximum value of secondary voltage

$$V_m = \sqrt{2} \times V_2 = \sqrt{2} \times 46 = 65.05 \text{ volts}$$

1 Mark

Therefore, DC voltage $V_{dc} = \frac{V_m}{\pi} = \frac{65.05}{3.14} = 20.71 \text{ volts}$

1 Mark

2. PIV of Diode = $V_m = 65.05 \text{ volts}$.

½ Mark