



# 17305

16117

4 Hours / 100 Marks

Seat No.

--	--	--	--	--	--	--	--

- Instructions :**
- (1) All questions are **compulsory**.
  - (2) Illustrate your answers with neat sketches **wherever** necessary.
  - (3) Figures to the **right** indicate **full** marks.
  - (4) Assume suitable data, if **necessary**.
  - (5) Mobile Phone, Pager and any other Electronic Communication devices are **not** permissible in Examination Hall.

**Marks**

1. a) Draw conventional representation for **any six** of the following :

**12**

- |                        |                  |
|------------------------|------------------|
| i) Cast iron           | ii) Gate valve   |
| iii) External thread   | iv) Bevel gear   |
| v) Short break in pipe | vi) Counter sunk |
| vii) Off-set-section   | viii) Worm gear. |

b) Attempt **any two** of the following :

**8**

- i) Draw the symbols for the following.
 

1) Spot weld	2) Single U butt weld
3) Convex double V butt weld	4) Seam weld.
- ii) The shaft size is given as  $40 \begin{matrix} -0.02 \\ -0.04 \end{matrix}$  and the hole size is  $40 \begin{matrix} +0.02 \\ -0.04 \end{matrix}$ . Determine the type of fit between them.
- iii) State the meaning of the symbol shown in Fig. No. 01.

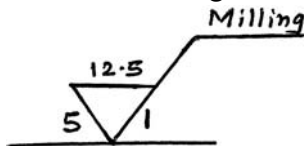

Fig. No. 01

Q. No. 01(b) (iii)

2. a) Fig. No. 02 shows incomplete front view, top view and part auxiliary front view complete the front view (use first angle method of projection).

**12**

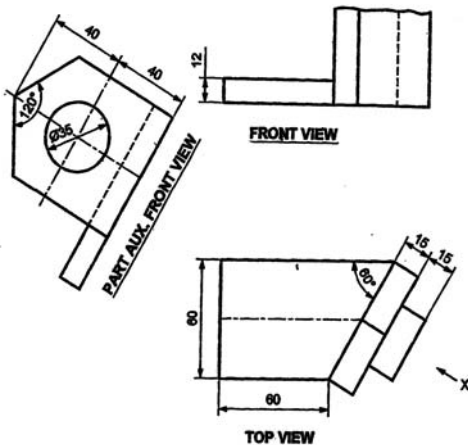

Fig. No. 02

Q. No. 2(a)

P.T.O.



b) Attempt **any two** of the following :

- i) Draw the symbols of the following features which are controlled in geometrical tolerance.
  - 1) Circularity
  - 2) Angularity
  - 3) Straightness
  - 4) Profile of any surface.
- ii) Two rectangular plates are to be welded with each other along the length. The thickness and length of both plates 12 mm and 60 mm respectively. The plates are to be 'U' butt welded with convex counter. Prepare welding drawing.
- iii) Refer Fig. No. 03. Explain meaning of every term.

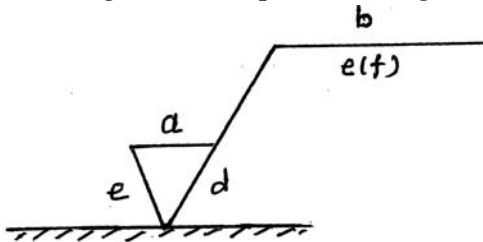

Fig. No. 03

Q. No. 2(b) (iii)

3. Attempt **any two** of the following :

20

- a) A cone base diameter 70 mm and axis height 80 mm is kept on the H.P. on its base. It is penetrated by horizontal cylinder of diameter 34 mm with its axis parallel to V.P. and intersecting the axis of the cone at a distance of 20 mm above the base of the cone. Draw the projections of solids showing curves of intersection. Length of cylinder is 100 mm.
- b) A vertical cylinder of 60 mm diameter is penetrated by another cylinder of the same size. The axis of penetrating cylinder is parallel to both H.P. and V.P. and is 12 mm away from the axis of the vertical cylinder and in front of observer. Draw the projections of solids showing curves of intersection. Assume the axis length of vertical and horizontal cylinder 100 mm and 110 mm respectively.
- c) A vertical square prism base 50 mm side and height 90 mm is completely penetrated by a horizontal square prism, 35 mm side and axis length 90 mm so that their axes are 6 mm apart and in front of the observer. The axis of the horizontal prism is parallel to V.P. while the faces of both prisms are equally inclined to the V.P. Draw the projections of the prisms showing lines of intersections.

4. Attempt **any one** of the following :

20

- a) Fig. No. 04 shows details of screw jack. Draw sectional F.V. and T.V. of the assembly, prepare bill of material. Indicate type of fit.

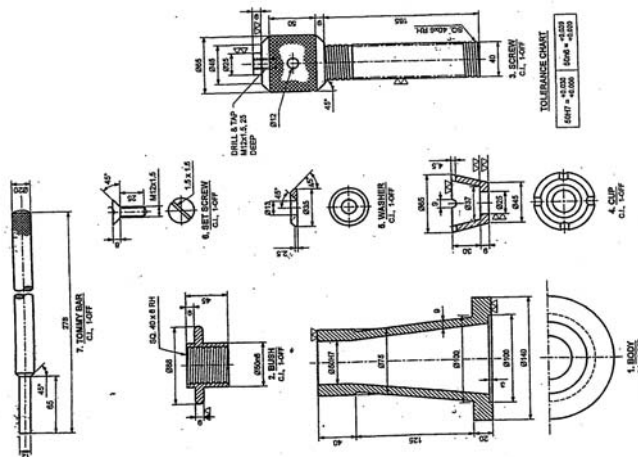

Fig. No. 04

Q. No. 4(a) Screw Jack



b) Fig. No. 05 shows details of universal coupling. Draw sectional F.V., T.V. of the assembly and prepare bill of material. Indicate type of fit.

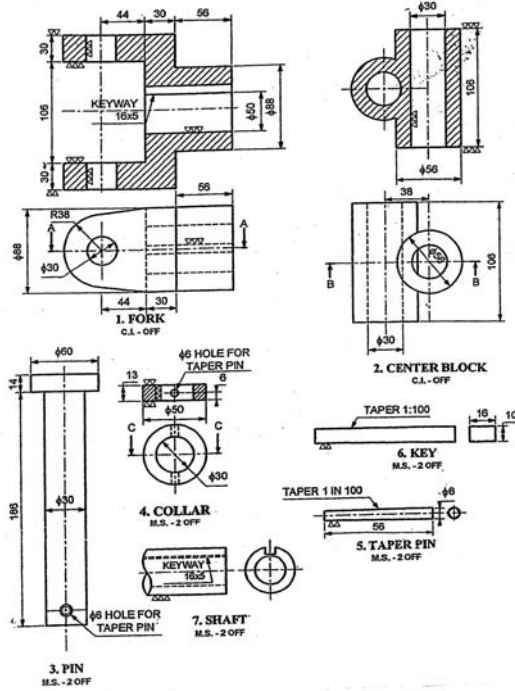

Fig. No. 05

Q. No. 4(b) Universal Coupling

5. Attempt any one of the following :

20

a) Fig. No. 06 shows the assembly of piston and connecting rod assembly. Draw the detail drawing of following parts.

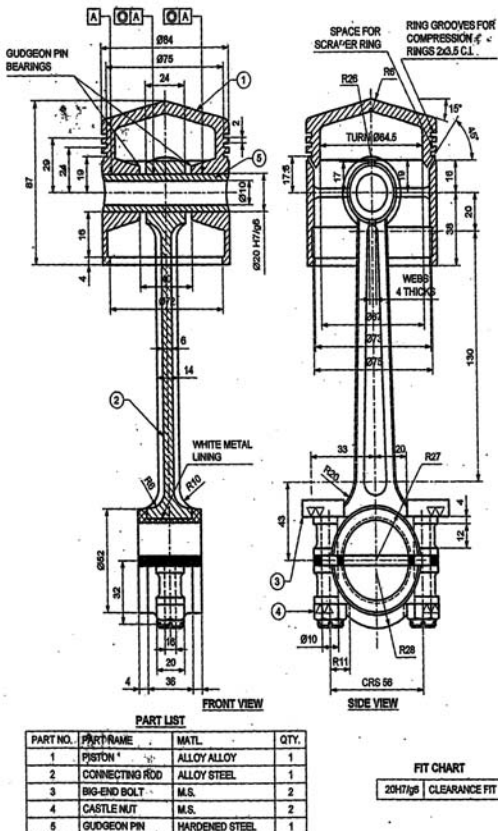

Fig. No. 06

Q. No. 5(a) Piston and connecting rod assembly



- 1) Piston-sect. F.V. and S.V.
  - 2) Connecting Rod F.V. and S.V.
  - 3) Big end Bolt-F.V. and T.V.
  - 4) Gudgeon pin F.V. and S.V.
- b) Fig. No. 07 shows assembly of Non-Return valve. Draw detailed drawing of following.
- 1) Body-sect. F.V. and T.V.
  - 2) Valve-Front view and T.V.
  - 3) Valve seat F.V. and T.V.
  - 4) Indication of geometrical tolerance.

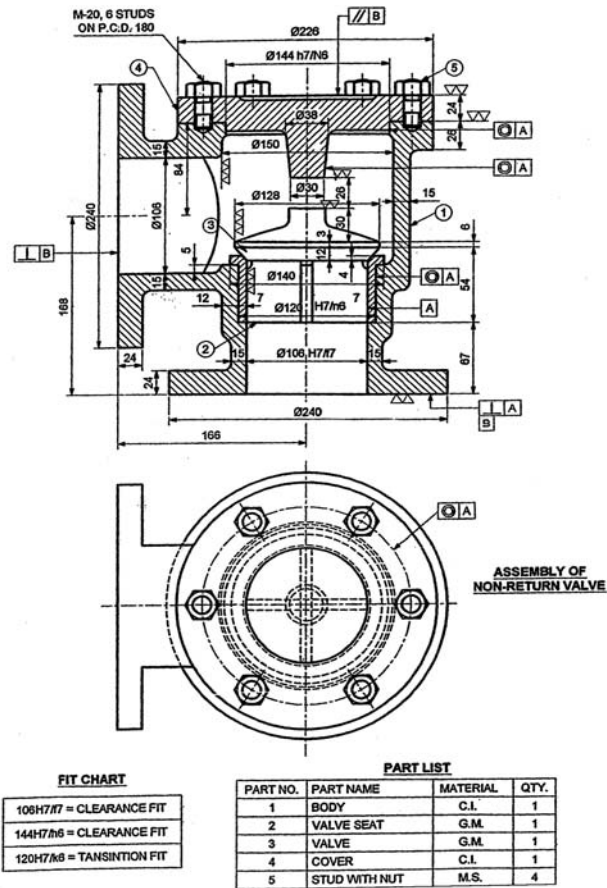

Fig. No. 07

Q. No. 5(b) Non-Return Valve