



WINTER- 16 EXAMINATION
Model Answer

Subject Code: 17658

Important Instructions to examiners:

- 1) The answers should be examined by key words and not as word-to-word as given in the model answer scheme.
- 2) The model answer and the answer written by candidate may vary but the examiner may try to assess the understanding level of the candidate.
- 3) The language errors such as grammatical, spelling errors should not be given more Importance (Not applicable for subject English and Communication Skills).
- 4) While assessing figures, examiner may give credit for principal components indicated in the figure. The figures drawn by candidate and model answer may vary. The examiner may give credit for any equivalent figure drawn.
- 5) Credits may be given step wise for numerical problems. In some cases, the assumed constant values may vary and there may be some difference in the candidate's answers and model answer.
- 6) In case of some questions credit may be given by judgement on part of examiner of relevant answer based on candidate's understanding.
- 7) For programming language papers, credit may be given to any other program based on equivalent concept.

1. Attempt any FIVE of the following: (Marks 20)

a) Draw the architecture of 89c51 microcontroller

Ans. (correct diagram 4 marks)

Block Diagram

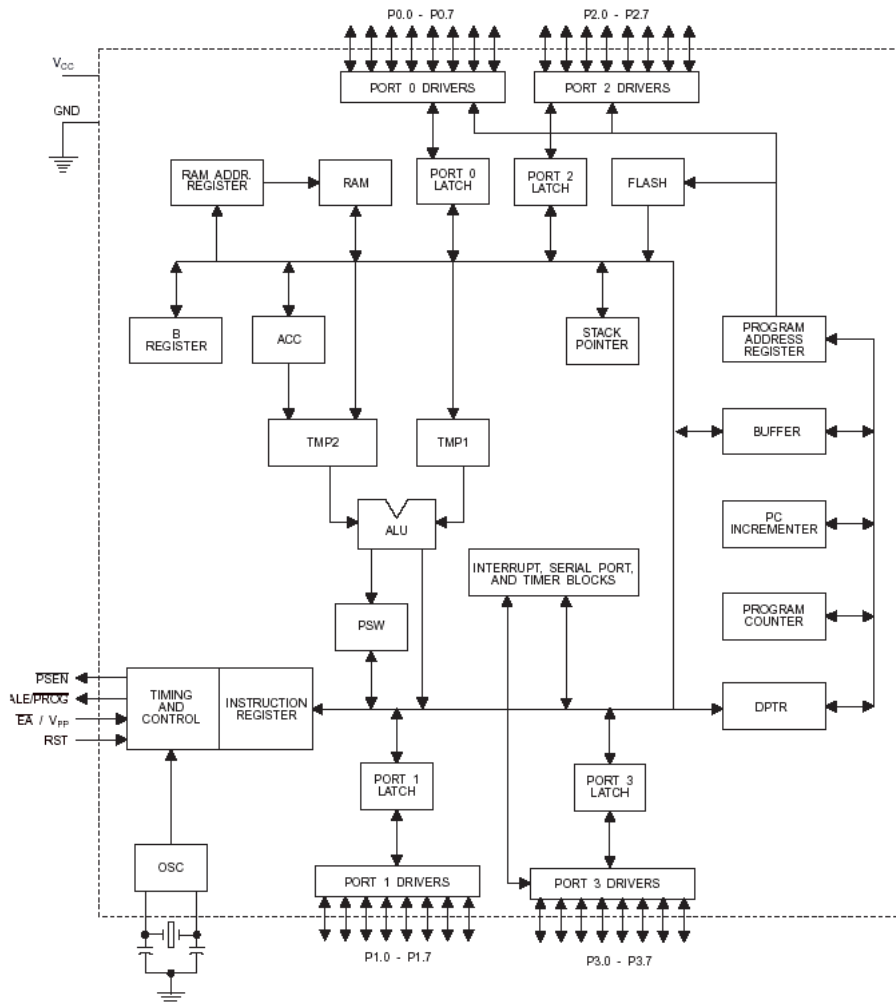



b) Write c language program to toggle all bits of P0,P1,P2 and P3 ports continuously with certain delay.

Ans.(correct logic 4 marks)

```
#include <reg51.h>
void Add_delay (unsigned int);
void main (void)

while(1)          //repeat loop
{
P0=0xff;          //toggle all bits of port 0
Add_delay (200); // add delay
P0=0x00;          //toggle all bits of port 0
Add_delay (200); //add delay
P1=0xff;          //toggle all bits of port 1
Add_delay (200); //add delay
P1=0x00;          //toggle all bits of port 1
Add_delay (200); //add delay
P2=0xff;          //toggle all bits of port 0
Add_delay (200); //add delay
P2=0x00;          //toggle all bits of port 2
Add_delay (200); //add delay
P3=0xff;          //toggle all bits of port 3
Add_delay (200); //add delay
P3=0x00;          //toggle all bits ofport 3
Add_delay (200); //add delay
}
void Add_delay (unsigned int delay)
{
unsigned int x,y;
for(x=0;x<delay;x++)
for (y=0;y<1275;y++);
}
```

c) Differentiate between synchronous and asynchronous serial communication.

Ans.(Each point 1 mark)

| Sr. No. | Synchronous | Asynchronous |
|---------|--|---|
| 1 | Same clock pulse is required at transmitter and receiver | Different clock pulse is required at transmitter and receiver |
| 2 | Used to transfer group of character | Used to transfer one character at a time |
| 3 | Synchronous character is required. | Synchronous character is not required. |



| | | |
|---|---|--|
| 4 | No start and stop signals are required | Start and stop signals are required. |
| 5 | Data transmission rate is greater then or equal to 20Kbps | Data transmission rate is less then or equal to 20 Kbps. |
| 6 | It is less reliable | It is more reliable |
| 7 | Error checking is not possible | Error checking is possible with parity bit. |

d) Draw the interfacing of 8x8 matrix keyboard with 89c51 microcontroller.- 4 marks

Ans:-

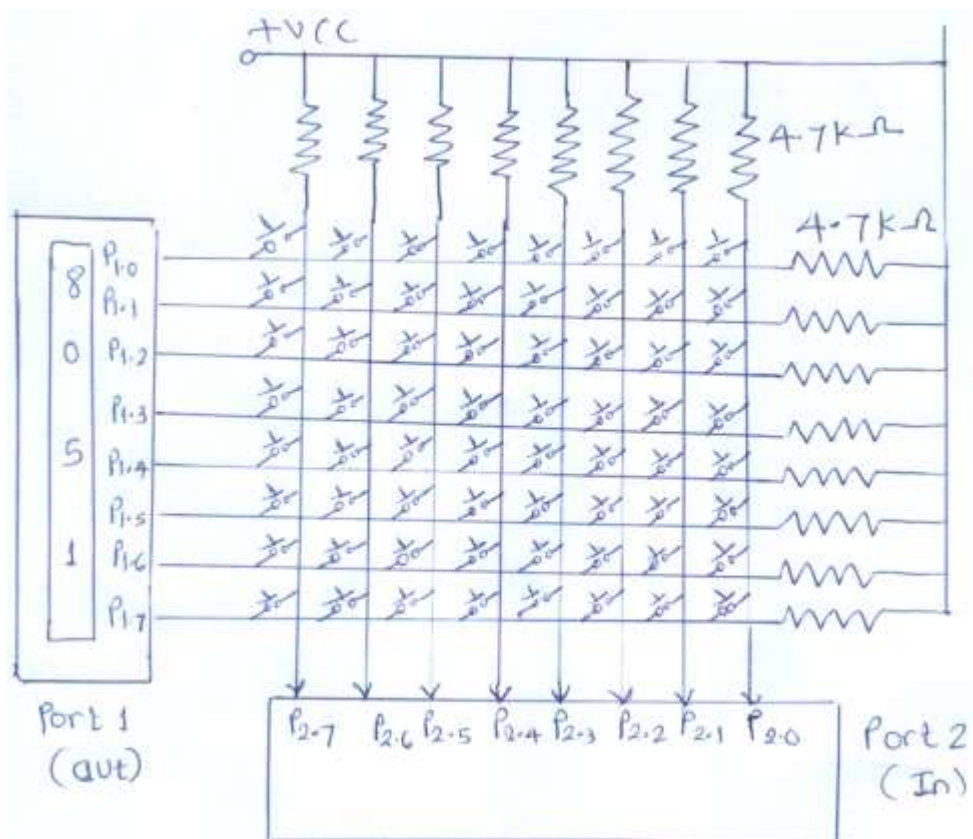



e) Write C language program to generate a triangular wave by using DAC 0808.

Ans. (correct logic 4 marks)

```
#include<reg51.h>

void main()
{
    unsigned char x;
    while(1)
    {
        for(x=0x00; x,0x7f; x++)
            { P2=x;
            }
        for(x=0x7f; x<0x00; x--)
            { P2=x;
            }
    }
}
```

f) State any four design matrices of an embedded system.

Ans. (any four matrices - 1 mark each)

Processor power

- Selection of the processor is based on the amount of processing power to get the job done and the register width required.
- 8 bit, 16 bit, 32 bit and 64 bit microcontrollers are provided.
- Processing power is different for different microcontrollers.
- High clock, speed and addressing capable microcontrollers are available.
- Very powerful DSPS are available for real time analysis of audio and video signals.

Memory

- Designer has to make an estimate of the memory requirement and must make provision for expansion.
- In a system, there are different types of memories : RAM, ROM, EPROM, PROM, etc.
- Secondary storage devices like HDD can be embedded into the system like mobile.
- Flash memory can be used instead of secondary memory. Hence, we can load NT in embedded system. E.g. Embedded Linux OS can be loaded into wristwatches.

Operating system

- In desktop, the selection of O.S. is limited.
- In embedded system, a variety of operating systems are available which can be ported into the embedded system.
- It is categorized as follows : Embedded OS, real time OS and mobile OS. These operating systems occupy less area in memory than desktop.
- For real time applications, we should use real time OS.



- We can develop our own OS kernel.
- We can use open source OS like Linux. This OS is free and can be customized.

Reliability

- Embedded system often reside in machines that are expected to run continuously for years without errors and in some cases recover by themselves, if an error occurs.
- So, the software is usually developed and tested more carefully than that for personal computers and unreliable moving parts such as disk drives, switches or buttons are avoided.

Unit cost

- The monetary cost of manufacturing each copy of the system, excluding NRE cost.

NRE cost

- The monetary cost of designing the system. Once the system is designed, any number of units can be manufactured without incurring any additional design cost (hence the term “non-recurring”).

Size

- The physical space required by the system, often measured in bytes for software, and gates or transistors for hardware.

Performance

- The execution time or throughput of the system.

Power

- The amount of power consumed by the system, which determines the lifetime of a battery, or the cooling requirements of the IC, since more power means more heat.

Flexibility

- The ability to change the functionality of the system without incurring heavy NRE cost. Software is typically considered very flexible.

Time to market

- The amount of time required to design and manufacture the system to the point the system can be sold to customers.

Time to prototype

- The amount of time to build a working version of the system, which may be bigger or more expensive than the final system implementation, but can be used to verify the system’s usefulness and correctness and to refine the system’s functionality.

Correctness

- Our confidence that we have implemented the system’s functionality correctly. We can check the functionality throughout the process of designing the system and we can insert test circuitry to check that manufacturing was correct.

Safety

- The probability that the system will not cause harm.

g) With the help of neat diagram describe binary semaphore.

Ans.(relevant diagram-2 mks, explanation- 2 mks)

- A binary semaphore can only take two values 0 or 1.
- Semaphore value 0 or 1 is used to indicate availability and unavailability respectively.
- Consider task 1 and task 2 wanting to access a resource (say printer).
- Semaphore is like a key when acquired count is 0. Task A acquires the shared resource and changes semaphore count to 0 to indicate shared resource is not available for another task.
- At the same time, task B wants to acquire the shared resource but has to wait till the count becomes 1.
- Now task B can acquire the shared resource.

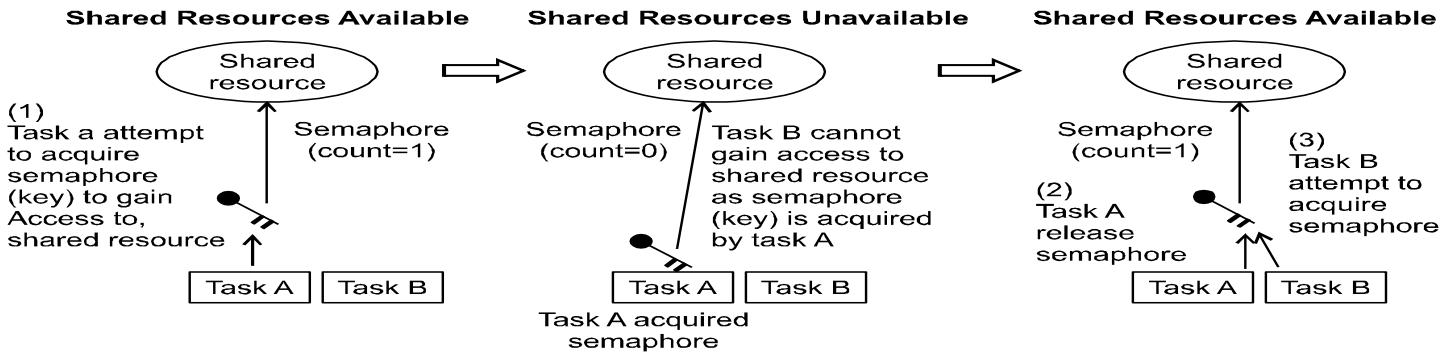

2. Attempt any four of the following:

(Marks: 16)

a) Differentiate between Harvard and Von Neumann architecture with suitable diagram.

Ans: (any four points- 4 mks)

| Sr.No | Von Neumann architecture | Harvard architecture |
|-------|---|---|
| 1 | | |
| 2 | The Von Neumann architecture uses single | The Harvard architecture uses physically separate |
| 3 | Requires single bus for instructions and data | Requires separate & dedicated buses for memories for instructions and data. |
| 4 | Its design is simpler | Its design is complicated |

| | | |
|---|--|---|
| 5 | Instructions and data have to be fetched in sequential order limiting the operation bandwidth. | Instructions and data can be fetched simultaneously as there is separate buses for instruction and data which increasing operation bandwidth. |
| 6 | Program segments & memory blocks for data & stacks have separate sets of addresses. | Vectors & pointers, variables program segments & memory blocks for data & stacks have different addresses in the program. |
| 7 | Examples of Von – Neumann Architecture: ARM 7 and Pentium Processors etc. | Examples of Harvard Architecture: 8051, ARM 9, AVR by Atmel Corporation and PIC microcontrollers by microchip Technology etc. |

b) Draw the pin out of RS232 and describe the function DCE and DTE pins.

Ans: (diagram 2 marks, each function 1 mark)

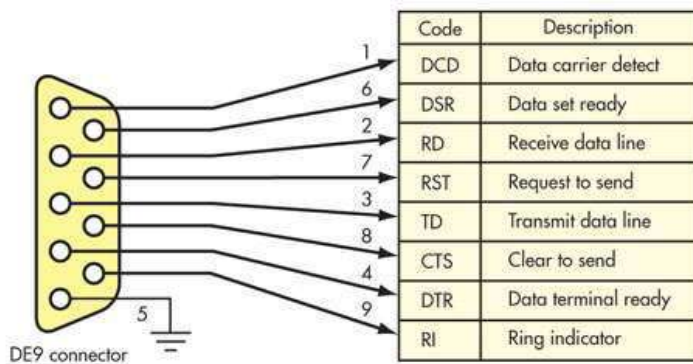

The RS-232 cable has two terminal devices namely Data Terminal Equipment (DTE) and Data communication Equipment (DCE)

Both device will send and receive the signals.

The data terminal equipment is computer terminal and data communication is Modems or controllers etc.

The DTE transmits data on TXD and receives data from the DCE on RXD.

c) Write a C language program to read P2 and P3. Shift the bits of P2 to right by 2 bits and P3 to left by 4 bits. Store the content of P2 to P0 and P3 to P1.

Ans. (correct logic 4 marks)

```
#include<regx51.h>
Void main(void)
{
```



```
Unsigned char a,b;
P2=0xFFH;      //set port 2 as an input
P3=0xFFH;      //set port 1 as an input
a=P2;          //read status of bits from P2
b=P3;          //read status of bits from P3
a=a>>3;        //shift P2 bits to right by 3 bits
P0=a;          //send to port 0
b=b>>4;        //shift P3 bits to left by 4 bits
P1=b;          //send to port 1
}
```

d)Write a C language program to rotate stepper motor by 90 degree clockwise. Assume step angle is 1.8 degree and 4 step sequence.

Ans. (correct logic 4 marks)

Step angle=1.8 degree

Total steps required=90/1.8=50

Four step sequence so

Count=50/4=12.5=approximately 13

```
#include<regx51.h>
void delay();
void main()
{
int x;
for (x=0;x,13;x++)
{
P0=0x33;
delay(10);
P0=0x66;
delay(10);
P0=0xcc
delay(10);
P0=0x99;
delay(10);
}
}
void delay(unsigned int t)
{
unsigned int x,y;
for(x=0;x<=t;x++)
for(y=0;y<=1275;y++);
}
```

}

e) What is embedded system? Draw the block diagram of an embedded system.

Ans(definition 1 mark,diagram 3 marks)

Defination: An Embedded system is a combination of computer hardware and software. As with any electronic system, this system requires a hardware platform and that is built with a microprocessor or microcontroller. The Embedded system hardware includes elements like user interface, Input/output interfaces, display and memory, etc. Generally, an embedded system comprises power supply, processor, memory, timers, serial communication ports and system application specific circuits.

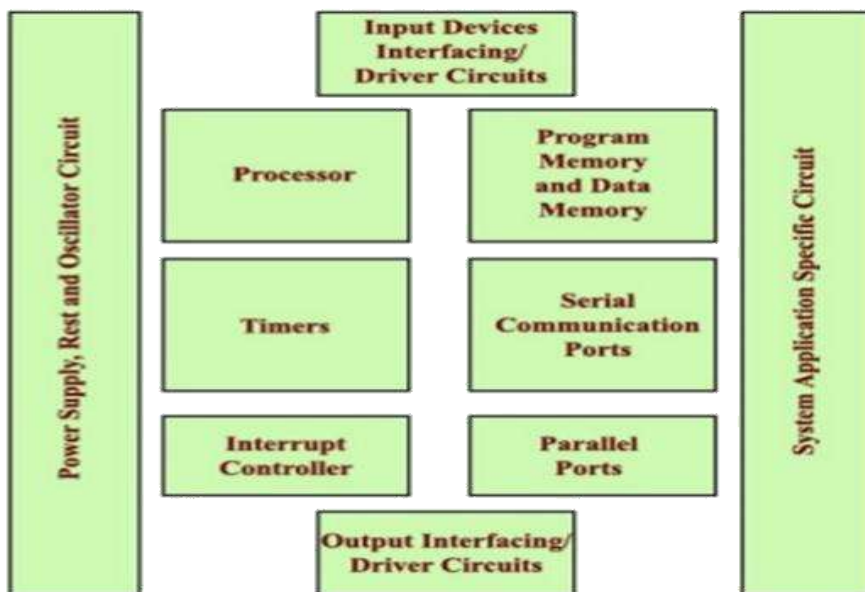

f)What is inter task communication? Describe the different methods of inter task communication.

Ans (definition 1 mark, any three methods description- 3marks)

1) **Intertask communication:** Intertask communication involves sharing of data among task through sharing of memory space, transmission of data etc. It is executed using following mechanism

1. Message queues
2. Pipe
3. Remote procedure calls

1) **Message queues:** A message queue is an object used for intertask communication through which task send or receives messages placed in a shared memory. The queue may follow first in first out, last in first out or priority sequence. Usually a message queue comprises of an associated queue control block, name,



unique ID, memory buffer, queue length, maximum message length and waiting list. A message queue of length 1 is called a mailbox.

- 2) **Pipes:** A pipe is an object that provides simple communication channel used for unstructured data exchange among task. A pipe does not store multiple messages but stream of bits. Also data flow from a pipe cannot be prioritized. There are two descriptors respectively at each end of the pipe for reading and writing. Data is written in to the pipes an unstructured byte streamed via one descriptor and read from the pipe in the FIFO order from the other.
- 3) **Remote procedure call:** It permits distributed computing where task can invoke the execution of the another task on remote computer.

3. Attempt any four of the following: (marks 16)

a) Define the following terms:

- i. Cross compiler**
- ii. Emulator**
- iii. De bugger**
- iv. In-circuit emulator**

Ans:- (each definition- 1 mks)

i) Cross compiler:

- cross complier executes on one processor but generates code for a different processor
- cross compiler is required to compile for multiple platforms from one machine
- cross compiler is used to compile for a platform for which it is not feasible to do the compiling like microcontrollers which don't support an operating system.
- The basic use of a cross compiler is to separate the build environment from the Target environment in embedded computers where a device has extremely limited resources or for compiling of multiple machines.

ii) Emulator:

- Emulator Emulates microcontroller inputs from sensors
- It emulates controlled outputs for the peripheral interfaces/systems
- It emulates target microcontroller inputs and socket to connect externally microcontroller unit

iii) Debugger:

- A debugger is a program that runs other programs which locates and fixes the errors in embedded system or c program code of an embedded hardware device.
- The debugger is able to examine program code and data during the execution of embedded program
- Most of the debugger also support functions such as single stepping execution ,addition of breakpoint at particular instruction and monitoring the vlues of some or all variables.
- Some debugger have also the facility to modify the state of the program while running ,instead observe it and continue the execution at a different location in the program by ignoring a logical error.
- Debugger is also useful as a general testing verification tool test coverage and performance analyser.
EXAMPLES ARE gnu, Eclipse etc in embedded systems

iv) In-circuit emulator:



- An in-circuit emulator (ICE) is a hardware device used to debug the software of an embedded system. It was historically in the form of bond-out processor which has many internal signals brought out for the purpose of debugging. These signals provided information about the state of the processor.
- An in-circuit emulator provides a window into the embedded system. The programmer uses the emulator to load programs into the embedded system, run them, step through them slowly, and view and change data used by the system's software.
- More recently the term also covers JTAG based hardware debuggers which provide equivalent access using on-chip debugging hardware with standard production chips.
- ICE's attach a terminal or PC to the embedded system. The terminal or PC provides an interactive user interface for the programmer to investigate and control the embedded system.
- In usage, an ICE provides the programmer with execution breakpoints, memory display and monitoring, and input/output control

b) Write C language program to read P0 and P1. Add the content of P0 and P1 and store the result to P2.

Ans. (correct logic 4 marks)

```
#include<reg51.h>
Void main(void)
{
Unsigned char a,b,c;
P0=0xFFH;      //set port 0 as an input port
P1=0xFFH;      //set port 1 as an input port
a=P0;          //read number from port 0
b=P1;          //read second number from port 1
c=a+b;         //add both numbers
P2=c;          //send result to port 2
}
```

c) State any two important features of following protocol:

- IrDA**
- Bluetooth**
- Zigbee**
- IEEE 802.11**

Ans(each protocol with two features- 1 mark each)

i) IRDA-



- InfraRed (IrDA) is a serial half duplex, line of sight based wireless technology for data communications between devices.
- The remote control of TV, VCD players etc. works on the infrared data communication principle.
- Infrared communication technique uses infrared waves of the electromagnetic spectrum for transmitting the data.
- IrDA supports point-to-point and point-to-multipoint communication provided that all the devices involved in the communication are within the line of sight.
- The typical communication range for IrDA lies in the range 10 cm to 1 m. The range can be increased by increasing the transmitting power of the IR device.
- IR supports data rates ranging from 9600 bits/second to 16 Mbps.
- IR is classified into Serial IR (SIR), Medium IR (MIR), Fast IR (FIR) depending on the speed of data transmission.

ii) Bluetooth features (any 2):-

- 1) IEEE Standard 802.15.1
- 2) Frequency (GHz) 2.4
 - 1) Maximum raw bit rate (Mbps) 1-3
 - 2) Typical data throughput (Mbps) 0.7-2.1
- 3) Maximum (Outdoor) Range (Meters) 10 (class 2), 100 (class 1)

iii) Zigbee features (any 2):-

- 1) IEEE Standard 802.15.4
- 2) Frequency (GHz) 0.868, 0.915, 2.4
- 3) Maximum raw bit rate (Mbps) 0.250
- 4) Typical data throughput (Mbps) 0.2
- 5) Maximum (Outdoor) Range (Meters) 10-100
- 6) Relative Power Consumption Very low

iv) IEEE 802.11(any two)

- Wi-Fi follows the IEEE 802.11 standard.
- Wi-Fi enabled devices contain wireless adaptor for transmitting and receiving data in the form of radio signals through an antenna. The hardware part of it is known as Wi-Fi Radio.
- Wi-Fi operates on 2.4 GHz or 5 GHz of radio spectrum and they can exist with other ISM band devices in a Wi-Fi network.
- For communication with devices over a Wi-Fi network, the device, when its Wi-Fi radio is turned ON, searches the available Wi-Fi network in its vicinity and lists out the Service Set Identifier (SSID) of the available networks.
- If the network is security enabled, a password may be required to connect to a particular SSID.
- Wi-Fi employs different security mechanisms like Wired Equivalent Privacy (WEP), Wireless Protected Access (WPA) etc. for securing the data communication.
- Wi-Fi supports data rates ranging from 1 Mbps to 150 Mbps and access/modulation method.

d) Draw the interfacing of relay with 89C51 microcontroller. Write C language program to make relay on off after certain delay.

Ans(diagram 2 marks,program 2 marks)

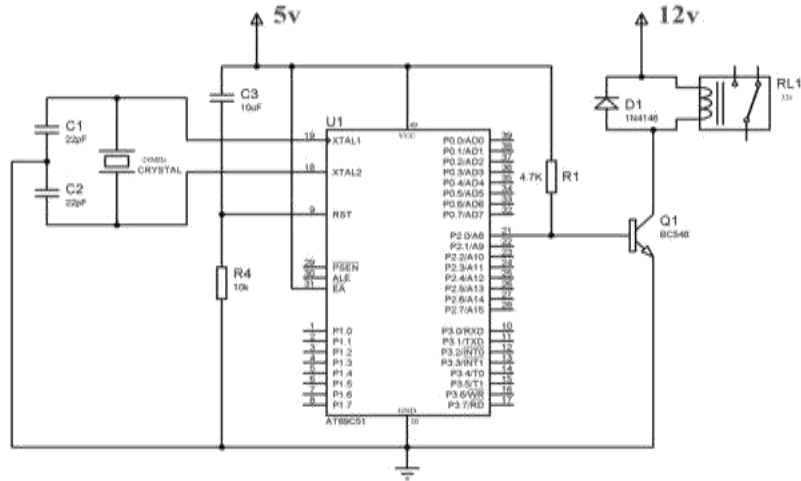

Program

```
#include <reg51.h>
sbit relay =P2 0;
void ms_delay (unsigned int);           //delay function
void main(void)
{
    P2=0;           //initialize port
    while(1)       //loop forever
    {
        relay=1;           //relay is on
        ms_delay(200);     //delay
        relay=0;           //relay is off
        ms_delay(200);     //delay
    }
}

void ms_delay (unsigned int itime)
{
    unsigned int x,y;
    for(x=0; x<itime; x++)
    for (y=0; y<1275; y++);
}
```

e)List the classification of an embedded system and describe any 2 methods in brief.

Ans:- Classification- 2 mks, explain any 2 in brief – 1 mks each)

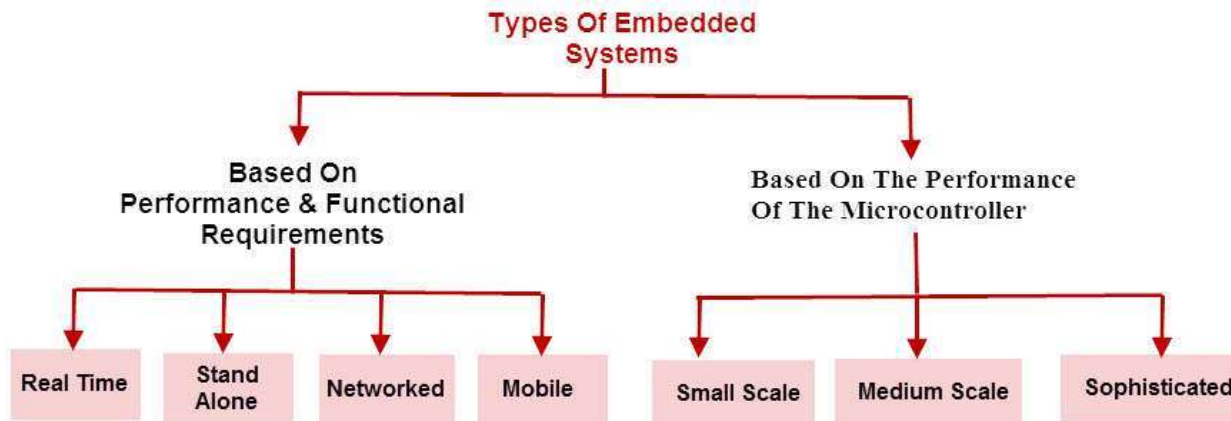

Explanation : (any two of the following) 2M

1. Stand Alone Embedded Systems -Stand-alone embedded systems do not require a host system like a computer, it works by itself. It takes the input from the input ports either analog or digital and processes, calculates and converts the data and gives the resulting data through the connected device-Which either controls, drives or displays the connected devices. Examples for the stand alone embedded systems are mp3 players, digital cameras, video game consoles, microwave ovens and temperature measurement systems.

2. Real Time Embedded Systems -A real time embedded system is defined as, a system which gives a required o/p in a particular time. These types of embedded systems follow the time deadlines for completion of a task. Real time embedded systems are classified into two types such as soft and hard real time systems.

3. Networked Embedded Systems -These types of embedded systems are related to a network to access the resources. The connected network can be LAN, WAN or the internet. The connection can be any wired or wireless. This type of embedded system is the fastest growing area in embedded system applications. The embedded web server is a type of system wherein all embedded devices are connected to a web server and accessed and controlled by a web browser. Example for the LAN networked embedded system is a home security system wherein all sensors are connected and run on the protocol TCP/IP

4. Mobile Embedded Systems-Mobile embedded systems are used in portable embedded devices like cell phones, mobiles, digital cameras, mp3 players and personal digital assistants, etc. The basic limitation of these devices is the other resources and limitation of memory.

5. Small Scale Embedded Systems -These types of embedded systems are designed with a single 8 or 16-bit microcontroller that may even be activated by a battery. For developing embedded software for small scale embedded systems, the main programming tools are an editor, assembler, cross assembler and integrated development environment (IDE).

6. Medium Scale Embedded Systems -These types of embedded systems design with a single or 16 or 32 bit microcontroller, RISCs or DSPs. These types of embedded systems have both hardware and software complexities.



For developing embedded software for medium scale embedded systems, the main programming tools are C, C++, and JAVA, Visual C++, and RTOS, debugger, source code engineering tool, simulator and IDE.

7. Sophisticated Embedded Systems-These types of embedded systems have enormous hardware and software complexities, that may need ASIPs, IPs, PLAs, scalable or configurable processors. They are used for cutting-edge applications that need hardware and software Co-design and components which have to assemble in the final system.

f) Differentiate between desktop OS and RTOS (Any 4 points)

Ans:(each difference 1 mark)

| General OS | RTOS |
|---|---|
| 1. It is used for general universal application | 1. It is used for dedicated electronic application |
| 2. There is no task deadline | 2. There is a task deadline in RTOS |
| 3. The time response of OS is not deterministic | 3. The time response of RTOS is deterministic. |
| 4. Depending upon application we cannot customize the OS | 4. Depending upon application, we can customize the RTOS. |
| 5. It does not optimize the memory resources | 5. It optimizes the memory resources. |
| 6. It is normally stored in Hard Disk | 6. It is normally started in semiconductor memory like EEPROM, Flash EEPROM |
| 7. The application are compiled and linked separately from the operating system | 7. The applications are usually linked with the RTOS |

Q 4 Attempt any FOUR of the following:(Marks :16)

a) Describe DSP and multicore processor in brief.

Ans :- (Each explanation 2 marks)

DSP-DSP are powerful special purpose 8 / 16 / 32 bit microprocessor designed to meet the computational demands and powerful constraints of today's embedded studio, video and communication applications. DSP are 2 to 3 times faster than the general purpose microprocessor in signal processing applications. This is because of the architectural difference between the two. DSPs implement algorithms in hardware which speeds up the execution, depends primarily on the clock for the processor. DSP can be viewed as a microchip designed for performing high speed computational operations for addition, subtraction and division. DSP unit having the following key units - Computational Engine, Program Memory, Data memory and I/O units

Multicore Processor

It is an integrated circuit in which two or more processor s core have been packaged for enhanced performance, reduced power consumption and more efficient simultaneous multitasking.

In multi core technology architecture ,a single physical processor contains the core logic of two or more processor and these processors are packaged into a single integrated circuit.



The multicore technology is mainly used for parallel computing which increases computer speed and efficiency. Multiple processes are used in mobile devices, desktops, workstations and servers.

Multicore processors will give the benefits to all software especially for multithreaded program.

b). Write C language program to read P1 and store the one's complement of P1 to P2.

Ans. (correct logic 4 marks)

```
#include<regx51.h>
void main(void)
{
    unsigned char a,b,c;
    P1=0xFFH;           //set port 0 as an input port
    P2=0x00FH;         //set port 1 as an output port
    a=P1;               //read number from port 1
    a=~a;               //logical not operator
    P2=a;               //store one's complement to port 2
}
```

c)State two advantages of I2C and USB.

Ans: (any two advantages- 2 mark)

Advantages of I2C (any 4)

- i. Multiple slave devices can be accessed with only three wires.
- ii. Implementation cost is low.
- iii. Can be implemented in hardware or software.
- iv. Supports multi master configuration.
- v. Easy to implement.

Advantages of USB (any 4)

- i. True plug and play nature.
- ii. Acceptable data rates for many applications.
- iii. Low cost
- iv. Robust connector system.
- v. Variety of types/sizes available.

d)Draw the interfacing of DC motor with 89C51 mic .Write C language program to rotate DC motor clockwise and anticlockwise.

Ans(diagram 2 marks, program 2 marks)

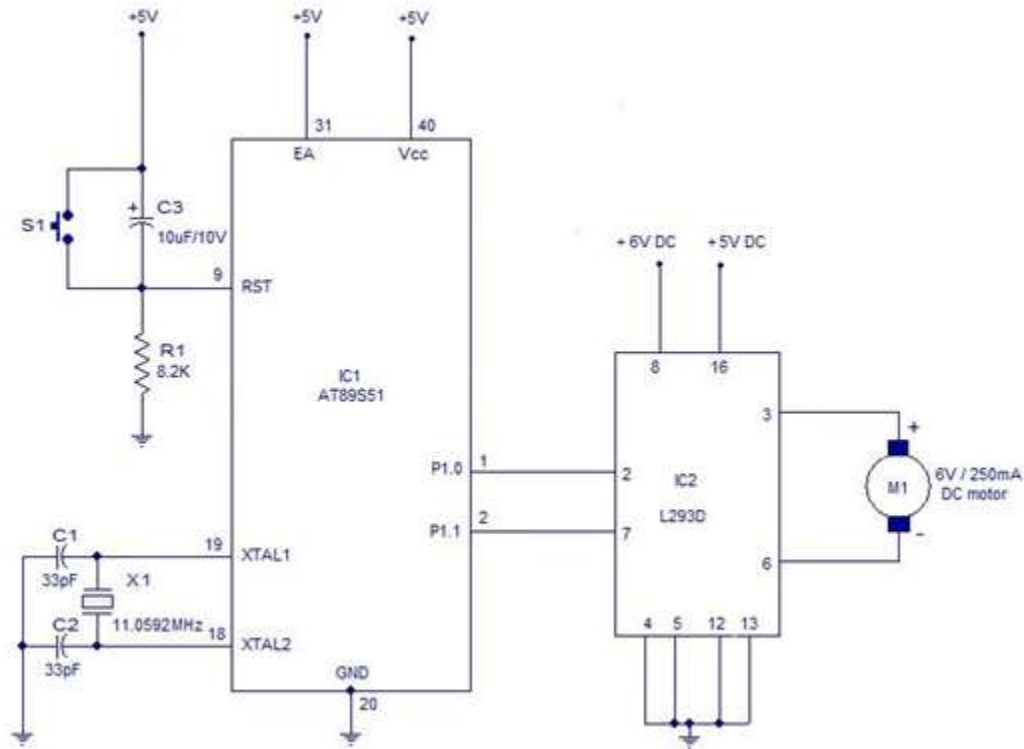

Program:

```

include<reg51.h>
sbit CW_DIRECTION=P1^0;           //P1.0 for Clock Wise direction
sbit CCW_DIRECTION=P1^1;         //P1.1 for counter clockwise direction
void main(void)
{
    CW_DIRECTION =0;

    while(1)
    {
        //Motor OFF

        CW_DIRECTION =1;
        CCW_DIRECTION =0;
    }
}

```



(NOTE: Program may change. Student can also use the other logic e.g. Motor direction can be controlled based on switch (connected to one of the port pins) status. Please check the logic and understanding of students.)

e) State two advantages and two applications of an embedded system.

Ans (each advantage and application 1 mark)

Application (any two)

Embedded systems play a vital role in our day to day life, starting from home to the computer industry, where most of the people find their job for a livelihood.

1. **Consumer electronics** : Cam-corders, cameras, mp3 players, DVD players etc.
2. **Household applications** : Television, washing machine, fridge, microwave oven etc.
3. **Home automation and security systems** : Air conditioners, sprinklers, intruder detection alarms, fire alarms etc.
4. **Automotive industry** : Antilock braking system, engine control, ignition systems, navigation system etc.
5. **Telecom** : Cellular telephones, handset multimedia applications.
6. **Computer peripherals** : Printers, scanners, fax machine etc.
7. **Computer networking system** : Network routers, switches, hubs, firewalls etc.
8. **Healthcare** : Different kind of scanners, ECG machines etc.
9. **Measurement and instrumentation** : Digital multi meters, digital CROs, logic analysers, PLS systems etc.
10. **Banking and Retail** : Automatic teller machines (ATM) and currency counters.
11. **Card Readers** : Barcode, smart card readers etc.

Advantages- (any two)

1. **Design and Efficiency** : The central processing core in embedded systems is generally less complicated making it easier to maintain.
2. **Cost** : The streamline makeup of most embedded system allows their parts to be smaller less expensive to produce.
3. **Accessibility** : Embedded systems are difficult to service as they are embedded inside the machine, so they have to be developed carefully.
4. **Maintenance** : They are easier to maintain because the supplied power is embedded in the system and does not require remote maintenance.
5. **Redundancies** : Embedded systems do not involve the redundant programming and maintenance involved in system models.

f) List the scheduling algorithm of RTOS .Describe any one scheduling algorithm in brief.

Ans: (State any four: 2 Marks, Explanation: 2M)

1. First in first out
2. Round-robin algorithm
3. Round robin with priority:
4. Shortest job first
5. Non Preemptive multitasking

6. Preemptive multitasking

Explanation: (any one of the following)

1. First in first out:

In first in first out scheduling algorithm the task which are ready to run are kept in queue and the cpu serves the task on first in first served basis. this scheduling algorithm is shown in fig. is very simple to implement but not well suited for most applications because it is difficult to estimate the amount of time a task has to wait for being executed . However this is good algorithm for an embedded system has to perform few small tasks all with small execution time. If there is no time critically and the number of tasks is small, this algorithm can be implemented

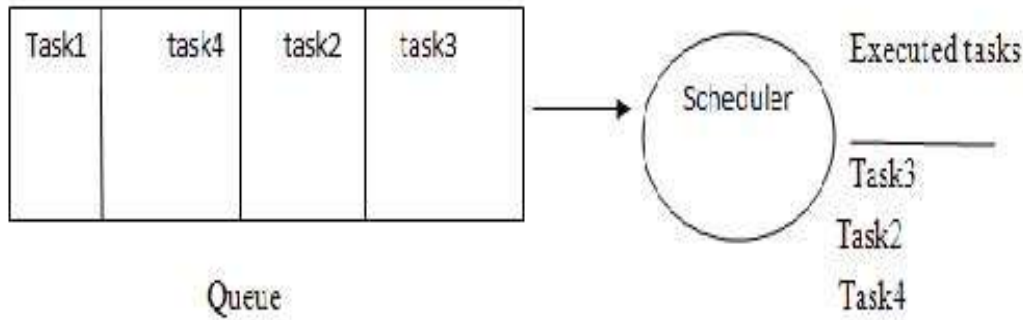

Fig Scheduling algorithm : FIFO

Q5 Attempt any FOUR of the following:(Marks :16)

a) **Differentiate between assembly language and embedded C(four points)**

Ans:- (any four points- 4 mks)

| Parameter | assembly language | Embedded C |
|-----------------|--------------------------------------|--|
| Execution time | Faster(Less execution time required) | Slower(More execution time required) |
| Time for coding | More time is required for coding | Less time required for coding and code is more efficient |



| | | |
|---------------|-------------|------|
| Hex file size | less | More |
| Debugging | Not so easy | Easy |

b) Write

C program to transfer 10 bytes from array A to array B.

Ans:- (Proper program and logic- 4 mks)

```
#include<reg51.h>
void main()
{
    char A[10]={1,2,3,4,5,6,7,8,9,10};
    char B[10];
    int i, j;
    for(i=0;i<10;i++);
    {
        for(j=0;j<8;j++) //for 1 byte transfer
        A[i]=B[i];
    }
}
```

Note: Any C Program with correct logic can be given marks.

c) Draw the interfacing of LCD display to 89C51 mic and describe the function of RS and RW pins.

Ans:- (Interfacing diagram- 2 mks, function- 1 mks each)

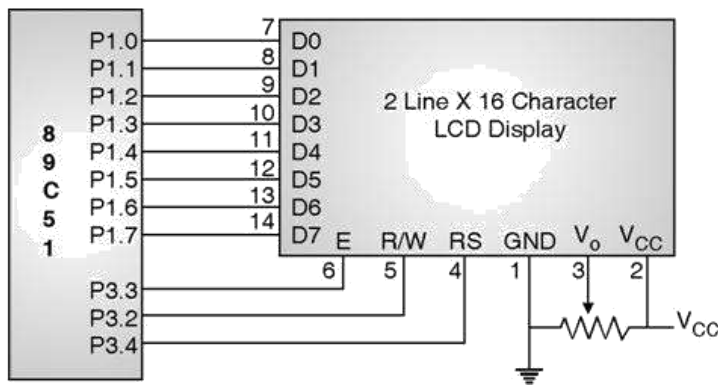

1) RS: RS is the register select pin used to write display data to the LCD (characters), this pin has to be high when writing the data to the LCD. During the initializing sequence and other commands this pin should low.

2) **R/W:** Reading and writing data to the LCD for reading the data R/W pin should be high (R/W=1) to write the data to LCD R/W pin should be low (R/W=0)

d) Draw the interfacing diagram of ADC with 89C51 microcontroller

Ans:- (4 marks –correct diagram)

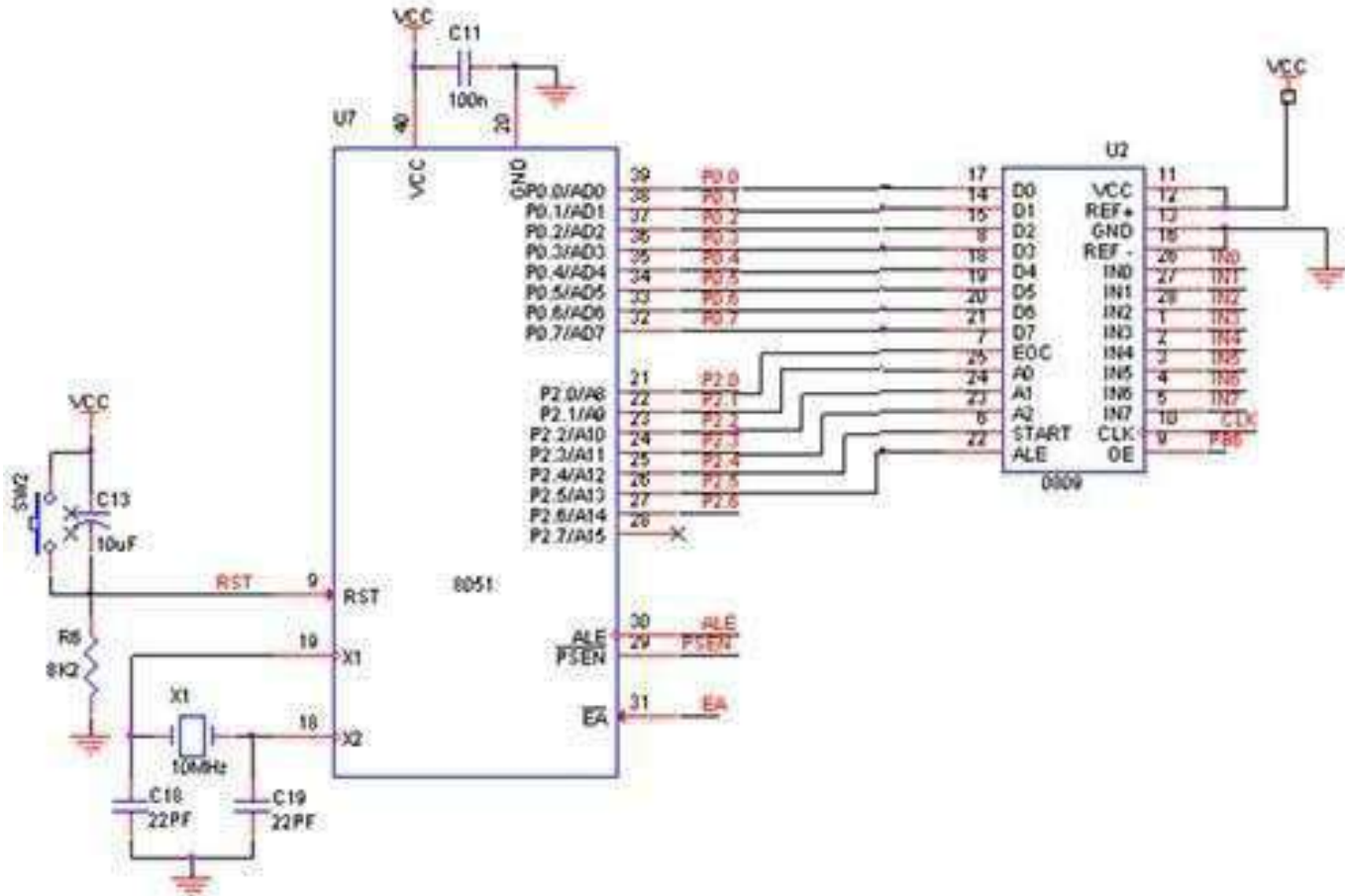

e) State the meaning of the following terms: multitasking , shared data problem

Ans :- (2 marks each)

Multitasking

- In computing, multitasking is the ability of an operating system to hold multiple processes in memory and switch the processor from executing one process to another process is known as multitasking.
- It creates the illusion of multiple tasks executing in parallel.
- The act of switching of execution among multiple tasks is known as context switching.
- In case of a system with a single processor, only one task is said to be running at any point in time, meaning that the processor is actively executing instructions for that task.
- Multitasking solves the problem by scheduling which task may be the one running at any time and when another waiting task gets a turn T.
- Even on computers with more than one processor (multiprocessor algorithm) multitasking allows many more tasks to be run than a processors.

Shared data problem

- A real time operating system intended to serve real time application process data in real time; with processing time in milliseconds.
- Essentially, RTOS has an advanced algorithm for scheduling multiple tasks. One of the key expectations from RTOS is to be able to quickly and predictably respond to multiple tasks.
- The challenge of running multiple tasks is of sharing of common resource; it could be memory, I/O address or device.
- If task 1 calls a function Read X for reading a shared data that is being interrupted and being modified by task 2, there is a chance that data read by task 1 is erroneous.
- If access to shared resource is not synchronized, it may lead to unpredictable behavior of the task.
- If a variable is used in two different processes and another task interrupts before the operation on that data is completed, then the value of the variable may differ from the one expected if the earlier operation has been completed. This condition is known as shared data problem.

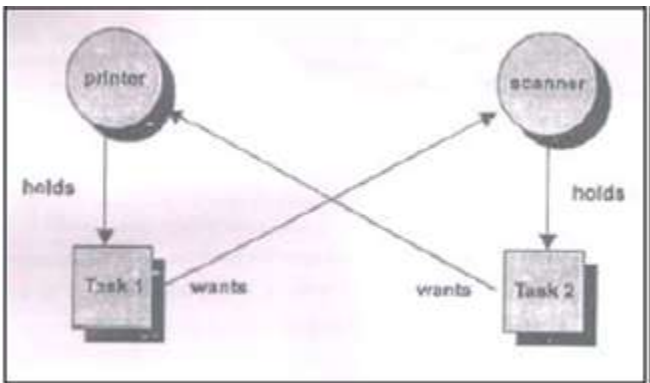

f). Draw and describe CAN bus protocol.

Ans:- (diagram- 2 mks, description – 2 mks)



- CAN (Controller Area Network) is a serial bus system used to communicate between several embedded 8-bit and 16-bit microcontrollers.
- It was originally designed for use in the automotive industry but is used today in many other systems (e.g. home appliances and industrial machines).
- Highest Baud Rate is 1Mbit.
- CAN uses a message oriented transmission protocol.
- There are no defined addresses, just defined messages.



SOF – Start of Frame

Identifier – Tells the content of message and priority

RTR – Remote Transmission Request

Q6 Attempt any four of the following (Marks 16)

a) what is meant by deadlock? Describe any three methods to prevent deadlock.

Ans:- (Meaning of deadlock with diagram – 1 mks)

Deadlock: A deadlock, also called as deadly embrace, is a situation in which two threads are each unknowingly waiting for resource held by other. Deadlock is the situation in which multiple concurrent threads of execution in a system are blocked permanently because of resources requirement that can never be satisfied.

In this example, task #1 wants the scanner while holding the printer. Task #1 cannot proceed until both the printer and the scanner are in its possession.

Task #2 wants the printer while holding the scanner. Task #2 cannot continue until it has the printer and the scanner.

Because neither task #1 nor task#2 is willing to give up what it already has, the two tasks are now deadlocked because neither can continue.

Methods of avoid Deadlock-(any three methods- 1 mks each)

- a) Mutual exclusion- If we could arrange matters such that no two processes were ever in their critical sections simultaneously, we could avoid race conditions. We need four conditions to hold to have a good solution for the critical section problem (mutual exclusion).
- 1) No two processes may at the same moment inside their critical sections.
 - 2) No assumptions are made about relative speeds of processes or number of CPUs.
 - 3) No process should outside its critical section should block other processes.
 - 4) No process should wait arbitrary long to enter its critical section.

- b) Hold & wait or resource holding- Hold and wait or resource holding: a process is currently holding at least one resource and requesting additional resources which are being held by other processes.
- c) No **preemption**: a resource can be released only voluntarily by the process holding it.
- d) Circular wait: a process must be waiting for a resource which is being held by another process, which in turn is waiting for the first process to release the resource. In general, there is a **set** of waiting processes,

$P = \{P_1, P_2, \dots, P_N\}$, such that P_1 is waiting for a resource held by P_2 , P_2 is waiting for a resource held by P_3 and so on until P_N is waiting for a resource held by P_1 .

b). Draw the interfacing of DAC 0808 with 89C51 microcontroller

Ans:- (correct diagram 4 marks)

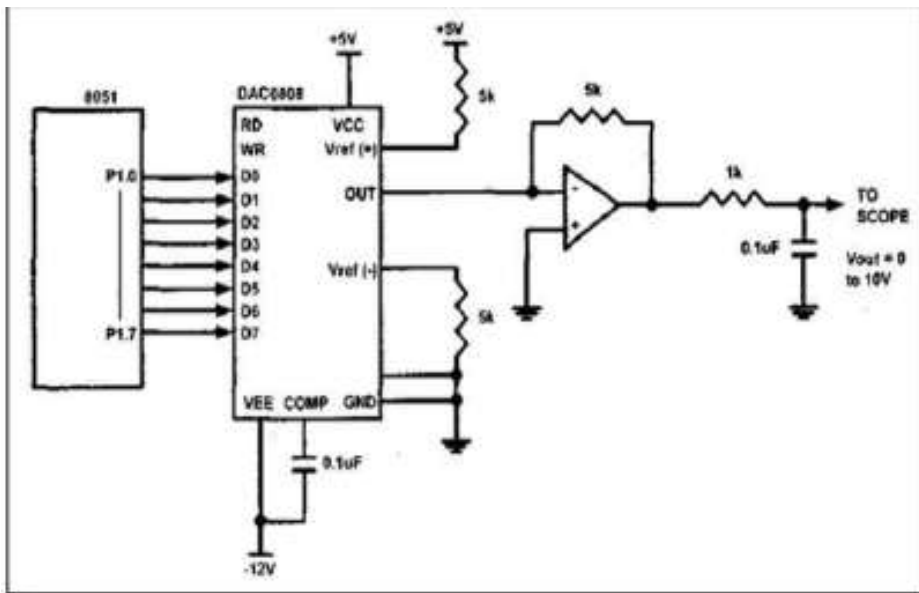

c) Describe the parallel protocols PCI and PCI-X

Ans(each protocol -2 marks)

PCI

1. Data transfer in PCI bus takes place according to a system clock. The first PCI by Intel supports 33 MHz maximum clock rate, while the newer PCI buses now supporting maximum clock frequency of 66 MHz.
2. PCI implements a 32-bit multiplexed Address and Data bus (AD[31.0]). It architects a means of supporting a 64-bit data bus through a longer connector slot, but most of today's personal computers support only 32-bit data transfers



through the base 32-bit PCI connector. At 33 MHz, a 32-bit slot supports a maximum data transfer rate of 132 Mbytes/sec. and a 64-bit slot supports 264 Mbytes/sec.

3. The multiplexed Address and Data bus allows a reduced pin count on the PCI connector that enables lower cost and smaller package size for PCI components.
4. PCI supports a rigorous auto configuration mechanism. Each PCI device includes a set of configuration registers that allow identification of the type of device (SCSI, Video Ethernet, etc.) and the company that produced it. Other registers allow configuration of the device's I/O addresses, memory addresses, interrupt levels, etc.
5. PCI defines support for both 5 volt and 3.3 volt signaling levels.
6. Although used most extensively in PC compatible systems, the PCI bus architecture is processor independent. PCI signal definitions are generic allowing the bus to be used in systems based on other processor families.

PCI-X

- PCI-X is a computer bus and expansion card standard that enhances the 32-bit PCI local bus for higher bandwidth transmission.
- It was originally created by IBM, HP and Compaq in the year 1998.
- It is a double wide version of PCL, running at up to four times the clock speed but is otherwise similar in electrical implementation and uses the same protocol.
- It has been replaced by the similar PCI Express bus, with a completely different connector and a very different logical design.
- It provides number of slower connections in parallel but the new version PCI-Express gives single, narrow but fast serial connection.
- Clock speed of PCI-X is doubled from 66 MHz to 133 MHz.
- Maximum possible bandwidth is 1064M Bits/sec.
- Split transactions increase the efficiency.

d) Write C language program to generate a square wave of 2kHz on pin P1.1 by using timer 0 and mode 1. Assume crystal frequency is 11.0592MHz

Ans. (correct logic 4 marks)

Crystal frequency= 11.0592 MHz

$$\text{I/P clock} = 11.0592 \times 10^6 = 11.0592\text{MHz}$$

$$1/12 \times 11.0592\text{Mhz} = 921.6 \text{ Khz}$$

$$T_{in} = 1.085\mu \text{ sec}$$

For 2 kHz square wave

$$F_{out} = 2 \text{ KHz}$$

$$T_{out} = 1/2 \times 10^3$$

$$T_{out} = 500\mu \text{ sec}$$



Consider half of it = $T_{out} = 250\mu \text{ sec}$

$N = T_{out} / T_{in} = 250/1.085 = 230$

$65536 - 230 = (65306p10) = \text{FF1A}$

Program

```
#include<reg51.h>

void delay(void);

sbit p=P1^5;

void main (void)
{
while (1)
{
    p=~p;
    delay();
}
}

void delay()
{
    TMOD=0X01;    //set timer 0 in mode 1 i.e. 16 bit number
    TL0=0X1AH;    //load TL register with LSB of count
    TH0=0XFFH ;  //Load TH register with MSB of count
    TR0 =1        //Start timer 0
    While(TF0==0) //wait until timer rolls over
    TR0=0;        //Stop timer 0
    TF0=0;        //Clear timer flag 0
}
```

e) Draw the interfacing diagram of key and LED to 89C51 mic on pins P1.0 and P2.0 respectively. Write a C language program to read the status of key and display it on LED.

Ans (diagram 2 marks, program 2 marks)

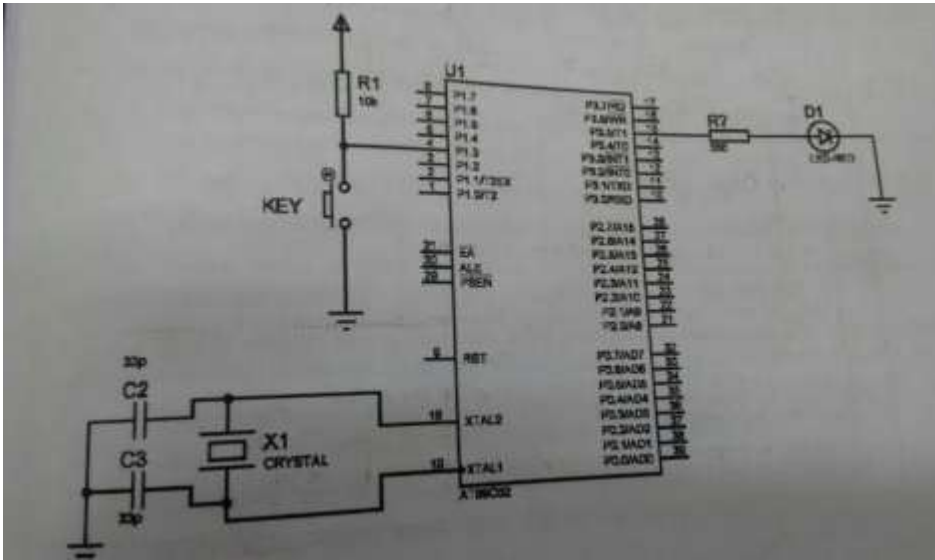

Program

```
#include<reg51.h>

sbit sw=P1^3; //make P1.3 as input
sbit led=P3^5; //make P3.5 as output

void main (void)
{
sw=1;
led=0;
while(1) //repeat loop
{
if(sw==0) //if switch is closed on the led else off the led
led=1;
else
led=0;
} //end of while
} //end of main
```



f) Write a C language program to transfer the message “MSBTE” serially at 9600 baud rate ,8 data bit and 1 stop bit.

Ans: (04M for correct program with comments)

NOTE: Student may use another method for program any other correct method can be consider

```
#include <reg51.h>
void main(void)
{
    unsigned char text[ ] = “MSBTE”; //initialize array
    TMOD = 0x20; //Initialize timer 1 in mode 2
    TH1 = 0xFD; //baud rate 9600
    SCON = 0x50; //start serial communication ( 8bit , 1 stop bit , REN )
    TR1 = 1; //start timer 1
    for(i=0;i<6;i++) //Read array and transmit serially till end
    {
        SBUF = text[i];
        while(TI==0); //check interrupt
        TI = 0; //clear interrupt
    }
}
```
