

WINTER- 16 EXAMINATION
Model Answer

Subject Code:

17657

Important Instructions to examiners:

- 1) The answers should be examined by key words and not as word-to-word as given in the model answer scheme.
- 2) The model answer and the answer written by candidate may vary but the examiner may try to assess the understanding level of the candidate.
- 3) The language errors such as grammatical, spelling errors should not be given more Importance (Not applicable for subject English and Communication Skills).
- 4) While assessing figures, examiner may give credit for principal components indicated in the figure. The figures drawn by candidate and model answer may vary. The examiner may give credit for any equivalent figure drawn.
- 5) Credits may be given step wise for numerical problems. In some cases, the assumed constant values may vary and there may be some difference in the candidate's answers and model answer.
- 6) In case of some questions credit may be given by judgement on part of examiner of relevant answer based on candidate's understanding.
- 7) For programming language papers, credit may be given to any other program based on equivalent concept.

1. a) Attempt any THREE of the following: 12

i) Draw block diagram of basic cellular system. State advantages of cellular system.

Ans:- (Diagram- 2 mks, any four advantages- 2 mks)

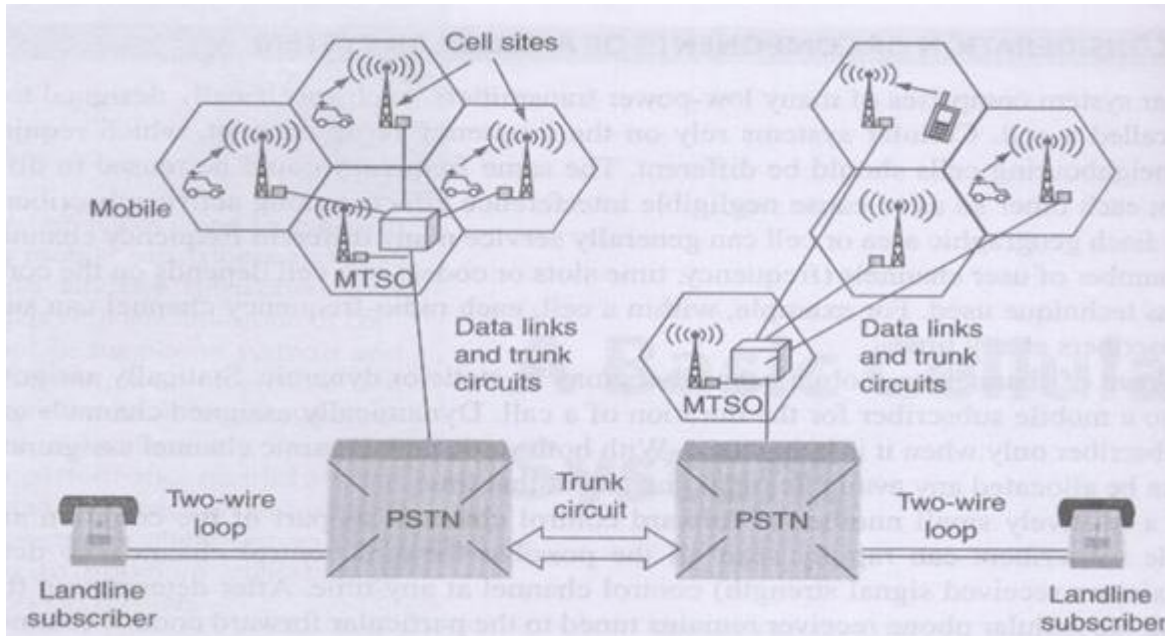

Fig: Block diagram of basic cellular system

Advantages of cellular system:

1. Higher capacity- Smaller the size of the cell more the number of concurrent users i.e. huge cells do not allow for more concurrent users.
2. Less transmission power- Huge cells require a greater transmission power than small cells.



3. Local interference only-For huge cells there are a number of interfering signals, while for small cells there is limited interference only.
4. Robustness-As cellular systems are decentralized, they are more robust against the failure of single components.

ii) List the following specifications of EDGE 2.5 G standard.

- (1) Backward compatibility
- (2) Channel bandwidth
- (3) Data rate
- (4) Duplexing method

Ans: (Relevant answer – 4 mks)

Specifications of EDGE 2.5 G standard

- 1) Backward compatibility – GSM
- 2) Channel bandwidth – 200 KHz
- 3) Data rate – 547.2 kbps
- 4) Duplexing method - FDD

iii) Compare IS-95B standard with GPRS with respect to following points.

- (1) Backward compatibility
- (2) Channel bandwidth
- (3) Duplexing Tech
- (4) No. of voice channels

Ans:- (Relevant comparison points- 4 mks)

	IS-95B	GPRS
Backward compatibility	IS.95	GSM
Channel bandwidth	1.25 MHz	200 KHz
No of voice channels	64	8 per carrier
Duplexing method	FDD	TDD

iv) Illustrate operation of cordless telephone system with the help of neat sketch.

Ans: (Block diagram- 2 mks, operation- 2 mks)

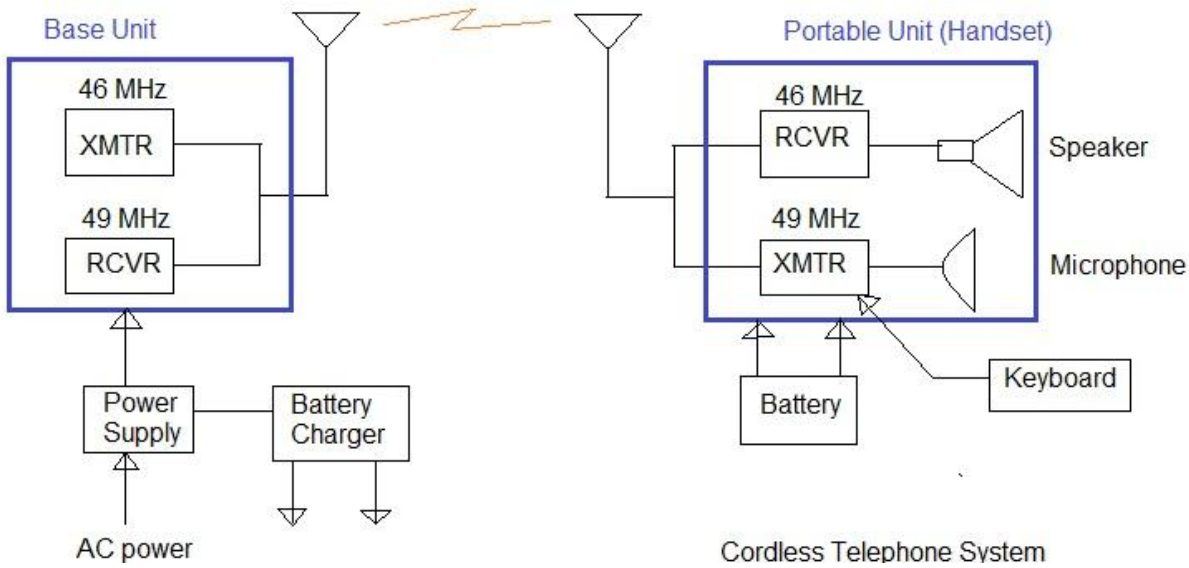

OR

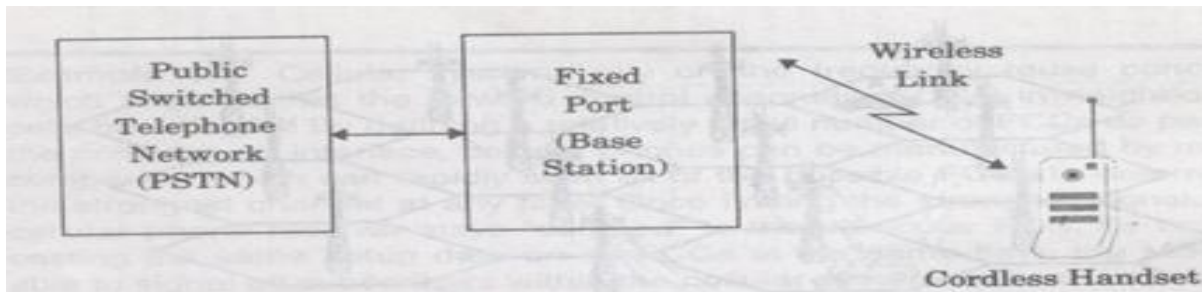

OR

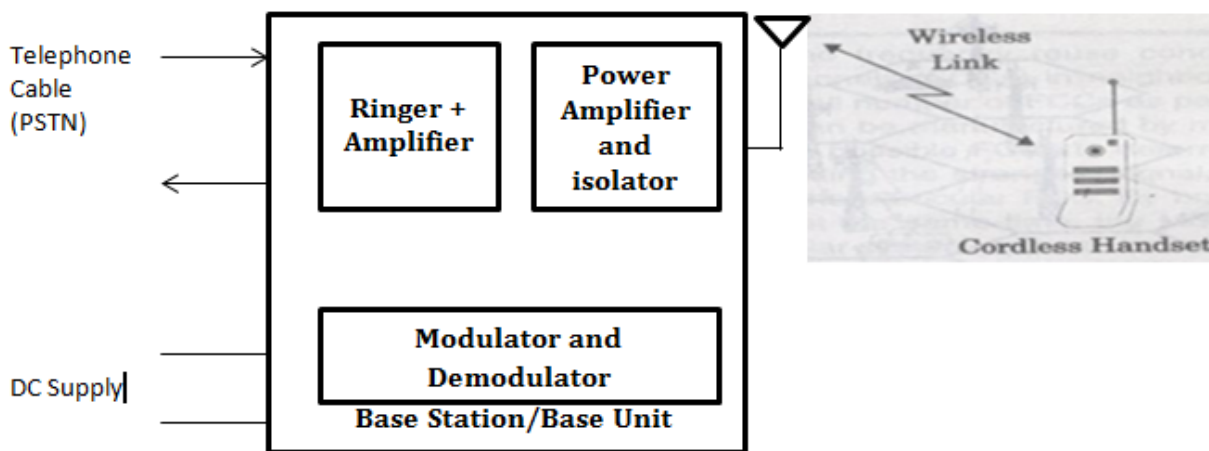

- Cordless Telephone Systems are full duplex communication systems that use radio to connect a portable handset to a dedicated base station, which is also connected to a dedicated telephone line with a specific telephone number on PSTN.

- The fixed port of a cordless telephone is nothing but the base unit on which cordless handset is placed, is connected to a telephone line and an adapter to produce a dc supply for various electronic circuits inside the base unit.
- The communication between the base unit and the handset is wireless and the range is limited to 50 meters.
- In the base unit all call processing circuits like amplifiers and also ring circuit is present. In addition a transceiver is also present which is used for communication with the handset.
- In handset also the transceiver along with an antenna, amplifier, microphone and loud speaker are present.
- 1st generation cordless telephone systems could cover only distance of a few ten meters (approximately 50m) and can be operated solely as extension telephones to a transceiver connected to a subscriber line on the PSTN and are primarily for in-home use.
- 2nd generation cordless telephone systems could cover distance of a few hundred meters which allows subscribers to use their handsets at many outdoor locations within urban centers.
- Cordless telephone systems provide the user with limited range and mobility, as it is not possible to maintain a call if the user travels outside the range of the base station.

b) Attempt any ONE of the following:

06

i) Describe various stages of call processing in GSM system with the help of neat diagram.

Ans: (Block diagram- 3 mks, operation-3 mks)

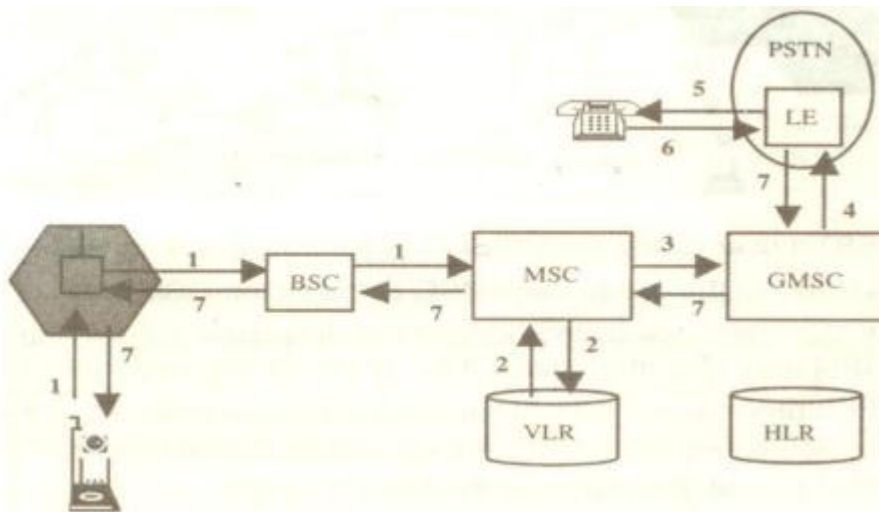

Mobile call origination in GSM

1. The MS sends the dialed number indicating service requested to the MSC (via BSS).
2. The MSC checks from the VLR if the MS is allowed the requested service. If so, MSC asks BSS to allocate necessary resources for the call.
3. If the call is allowed, the MSC routes the call to GMSC.
4. The GMSC routes the call to the local exchange of called user.
5. The LE alerts (applies ringing) the called terminal.

6. Answer back (ring back tone) from the called terminal to LE.
7. Answer back signal is routed back to the MS through the serving MSC which also completes the speech path to the MS.

(OR)

Mobile call termination:

1. The PSTN user dials the MSISDN of the called user in GSM.
2. The LE routes the call to the GMSC of the called GSM user.
3. The GMSC uses the dialed MSISDN to determine the serving HLR for the GSM user and interrogates it to obtain the required routing number.
4. The HLR requests the current serving VLR for the called MS for a MSRN (MS roaming number) so that the call can be routed to the correct MSC.
5. The VLR passes the MSRN to the HLR.
6. The HLR passes the MSRN to the GMSC.
7. Using the MSRN, the GMSC routes the call to the serving MSC.
8. The MSC interrogates the VLR for the current location area identity (LAI) for the MS.
9. The VLR provides the current location for the MS.
10. The MSC pages MS via the appropriate BSS. The MS responds to the page and sets up the necessary signaling links.
11. When the BSS has established the necessary radio links, the MSC is informed and the call is delivered to the MS.
12. When the MS answers the call, the connection is completed to the calling PSTN user.

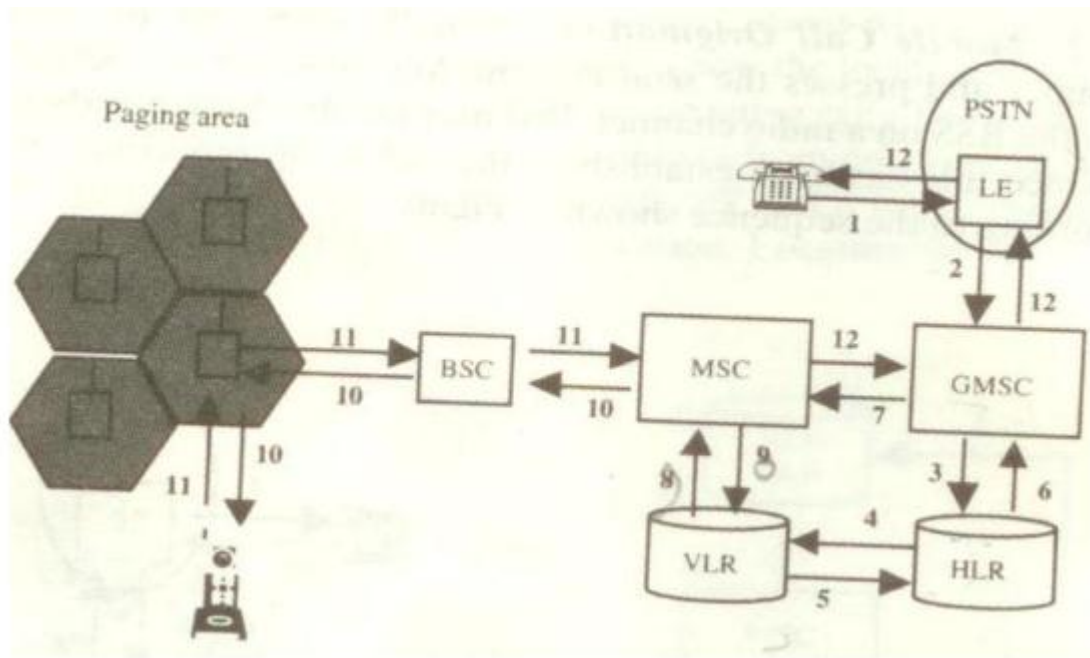

(OR)

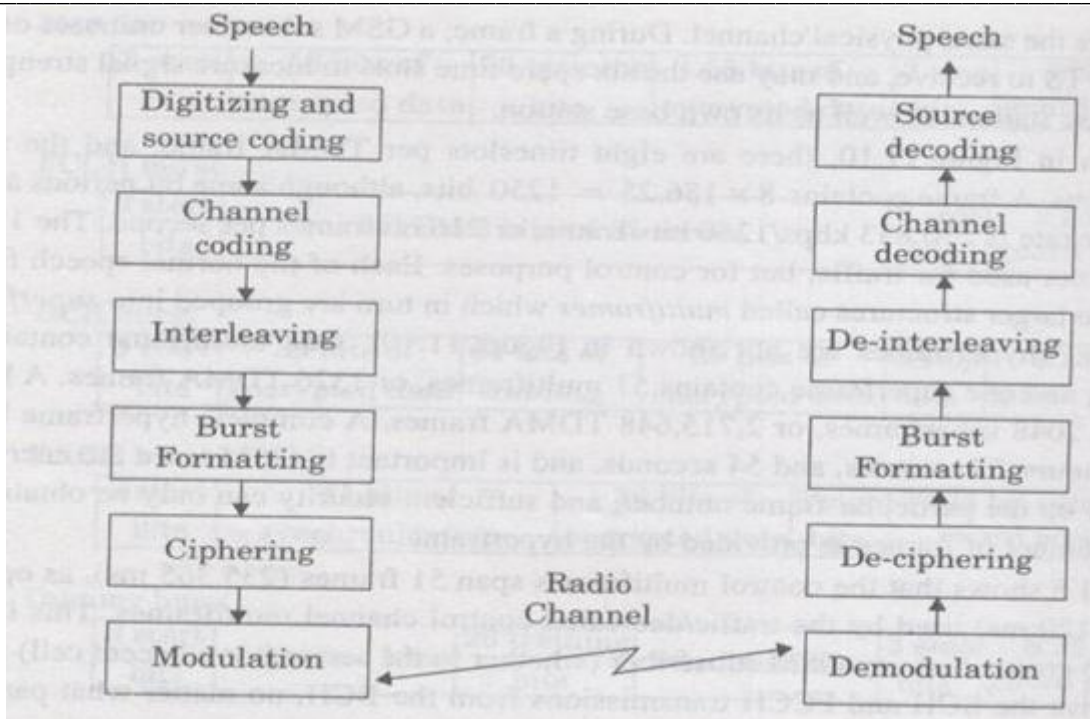

Fig: GSM Operations from speech input to output

■ Source Coding

- ❖ Source Encoding is a technique in which the encoder converts the digital input signal into another digital signal.
- ❖ It is used to reduce or eliminate redundancy for ensuring an efficient representation of source output.
- ❖ Various source coding techniques are:
 - ASCII(American Standard Code for Information Interchange)
 - EBCDIC(Extended Binary Coded Decimal Interchange Code)
 - Baudot Code

■ Channel Coding

- ❖ Channel coding is performed at the transmitter in order to minimize the effect of channel noise.
- ❖ It also converts the input signal in such a form which is compatible with the channel used for communication.
- ❖ Channel coding techniques add more bits into the message bits. These additional bits serve the purpose of error detection and correction.
- ❖ But these bits do not contain any information and therefore these bits are called as redundant bits.

■ Interleaving

- ❖ Total of 456 data bits can be transmitted within each 20mS speech frame or control message frame. This 456 data bits are broken into eight 57 bit sub-blocks.
- ❖ These eight sub-blocks which make up a single frame are spread over a 8 consecutive Traffic Channel(TCH) time slots.

■ Ciphering

- ❖ It modifies the contents of the eight interleaved blocks through the use of encryption techniques known only to the particular mobile station and base transceiver station.
- ❖ Two ciphering algorithms A3 and A5 are used in GSM to prevent unauthorized network access and privacy for the radio transmission respectively.

■ Burst Formatting

- ❖ It adds binary data to the ciphred blocks, in order to help synchronization and equalization of the received signal.



ii) Illustrate the process of call initiation from landline telephone to cellular phone with neat timing diagram.

Ans:

When a cellular phone is turned ON, but not yet engaged in a call, it first scans the group of forward control channels to determine the one with the strongest signal, and then monitors that control channel until the signal level drops below a usable level.

Call initiation by a landline (PSTN) subscriber to mobile user:

2 marks

- The mobile switching centre (MSC) dispatches the request to all base station in a cellular system.
- The Mobile Identification Number (MIN) which is subscriber telephone number is then broadcast as a paging message over all of the forward control channels throughout the cellular system.
- The mobile receives the paging message sent by BS which it monitors, and responds by identifying itself over the RCC.
- The BS relays the acknowledgement sent by the mobile and informs the MSC of handshake.
- The MSC instructs the BS to move the call to an unused voice channel pair within the cell.
- The BS signals the mobile to change frequencies to an unused forward and reverse voice channel pair.
- Another data message is transmitted on forward channel to instruct the mobile telephone to ring and mobile user to answer the phone.
- Figure below shows sequence of events involved in call connection.



MSC		Receives call from PSTN sends the requested MIN to all base stations			Verifies that the mobile has a valid MIN ESN Pars.	Requests BS to move mobile to unused voice channel pair		Connects the mobile with the calling party on the PSTN
BASE Station	FCC		Transmits page (MIN) for specified User				Transmits data message for mobile to move to specific voice channel	
	RCC			Receives MIN ESN Station class Mark and Passes to MSC				
	FVC							Begin Voice Transmission
	RVC							Begin Voice reception
Mobile	FCC		Receives page and matches the MIN with its own MIN				Receives data messages to move to specified voice channel	
	RCC			Acknowledges receipt of MIN and sends ESN and Station class Mark				
	FVC							Begin Voice reception
	RVC							Begin Voice Transmission

2. Attempt any FOUR of the following:

16

a) Describe the effect of co-channel interference in cellular systems. How it affects system capacity?

Ans: (effect- 2 mks, effect on system capacity – 2mks)

Co-channel cells: Frequency reuse implies that in a given coverage area, there are several cells that use the same set of frequencies. These cells are called co-channel cells.

Causes:

- i) Reduction of D/R ratio, which reduces distance between two co-channels.
- ii) Use of omnidirectional antennas at the base station.
- iii) Increasing the antenna height at the base station.

Effects of co-channel interference on system capacity:

The parameter Q, called the co-channel reuse ratio, is related to cluster size N,

$$Q = D/R = \sqrt{3N}$$

A small value of Q provides larger capacity since the cluster size N is small, whereas a large value of Q implies smaller level of co-channel interference.

Thus with reduction in co-channel interference there will reduction in system capacity.



b) State any four specifications of UMTS.

Ans:(any four- 4 mks)

Specifications of UMTS:

- It is more robust for multipath delays.
- It has very high packet data rates of 2.048 Mbps.
- It has very high channel bandwidth of 5 MHz
- It has backward compatibility with GSM systems.
- It has high frame structure of 16 slots per frame.
- It gives signals of higher voice and data quality and also small bit error rates.
- It has a common world-wide spectrum band.
- It has global seamless connectivity (roaming).

c) Name the systems A and B which supports following features.

	Parameter	A
1)	Frequency band	2400-2483.5 MHz
2)	Duplexing method with frequency hopping	TDD
3)	Channel BW	-1 MHz
4)	Modulation tech	GFSK

	Parameter	B
1)	Frequency band	384 kbps
2)	Duplexing method	TDD
3)	Channel BW	1.6 MHz
4)	Modulation tech	Smart antenna

Ans: System A is **Bluetooth**.

System B is **3G TD-SCDMA**

d) List four specifications of GPRS 2.5G GSM standard.

Ans: Specifications of GPRS 2.5G GSM standard:- (any four- 4 mks)

- Backward compatible – GSM.
- Channel BW – 200 KHz
- Data rate – 171.2 kbps
- No. of voice channels – 8 per carrier

e) State four features of Bluetooth.

Ans: **Features of Bluetooth: (any four -4 mks)**

1. Each Bluetooth device has the capability of sharing all of its features with other Bluetooth devices in the surrounding area.
2. For example, a Bluetooth phone can share information with a Bluetooth-enabled computer or printer, just like one Bluetooth-enabled computer can link to another
3. Bluetooth-enabled computer, sharing all the features, such as the Internet.
4. Bluetooth devices can communicate at ranges of up to 10 meters.
5. Bluetooth devices do not need to be in direct sight of each other.

f) Describe how “umbrella cell approach” is used in cellular system to reduce the number of hand-offs?

Ans: (**diagram- 2 mks, explanation- 2 mks**)

Explanation-Capacity of cellular system can be increased using additional cell sites but it is practically difficult to get new physical site in urban areas. Thus instead of new cell sites additional channels and base stations can be installed to increase the capacity. Different antenna heights and different power levels can be used to provide small and large cells located at single site. This technique is called as umbrella cell approach. This approach is used to provide large area coverage to high speed users while small area coverage to low speed users. It also ensures additional microcell channels for pedestrian users. The speed of each user is estimated by base station or MSC by evaluating how rapidly the short term average signal strength on RVC changes over time or with sophisticated algorithms. If high speed user in the large umbrella cell is approaching the base station, and its velocity is rapidly decreasing, the base station may decide to hand the user into the co-located microcell without MSC permission. This approach is basically used to reduce number of hand off for high speed users.

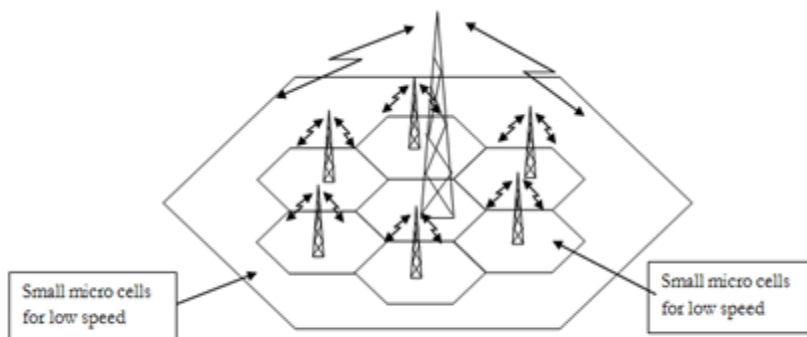

Fig: Umbrella cell approach

3. Attempt any FOUR of the following:

16

a) Draw block diagram of frequency synthesizer unit of mobile handset and state its function in cellular handset.

Ans:- (block diagram- 2mks, function-2 mks)

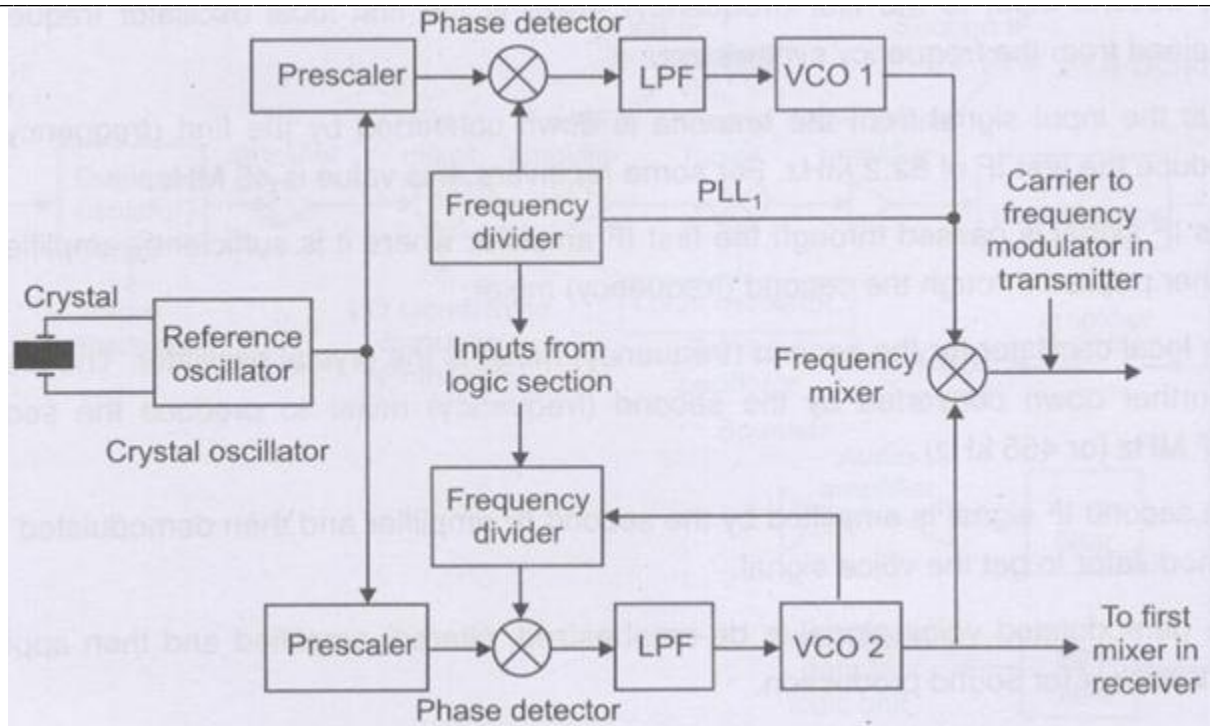
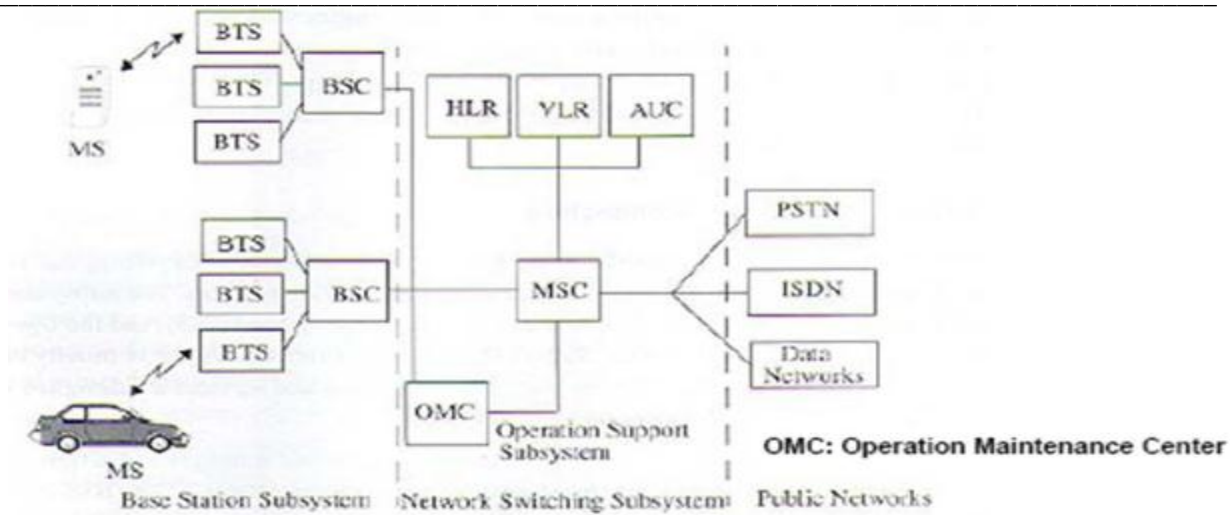

Fig: block diagram of frequency synthesizer unit of mobile handset

- The synthesizer is used for developing all the signals used by the transmitter and receiver.
- It uses the PLL circuits and a mixer.
- The crystal oscillator provides a reference for the two PLLs.
- The output of VCO-2 is used as a local oscillator frequency for the first mixer in the receiver.
- The outputs of the two VCOs are mixed together to produce the transmitter output frequency.
- The frequency divider block receives the divide by numbers from the logic section.
- These numbers are given by the MTSO computer.
- The divide by numbers will set the transmitting and receiving channel frequencies.
- The two outputs produced by the frequency synthesizer are applied to the modulator box in the transmitter and the first mixer in receiver respectively.
- Thus the frequency synthesizer acts a local oscillator which can produce a wide range of frequencies with high stability.

b) Draw GSM architecture and explain function of HLR and VLR.

Ans(diagram- 2 mks, each function- 1 mks)



Functions

1. Home Location Registers (HLR)—IM

- Permanent database about mobile subscribers in a large service area (generally one per GSM network operator)
- Database contains subscriber & location information
- Database contains IMSI (International Mobile Subscriber Identity), prepaid/postpaid, roaming restrictions, supplementary services
- Each Subscriber assigned IMSI to identify home user

2. Visitor Location Registers (VLR) –IM

Temporary database which stores IMSI & customer information for each roaming subscriber visiting the coverage area of particular MSC.

It updates whenever new MS enters its area, by HLR database.

It controls the mobiles roaming in its area .

c) **State the different techniques used to improve capacity and coverage in cellular system. Describe cell sectoring technique in detail.**

Ans:(4 methods- 2 mks, Sectoring explanation – 2 mks)

Different techniques used to improve capacity and coverage in cellular system are:

- 1) Cell sectoring
- 2) Cell splitting
- 3) Microzone cell concept
- 4) Repeaters

Cell Sectoring

- Decrease the *co-channel interference* and keep the cell radius R unchanged
 - Replacing single Omni-directional antenna by several directional antennas
 - Radiating within a specified sector
- The process of reducing the co-channel interference and thus increasing the capacity of the system by using directional antennas is known as *Sectoring*
- Cell increases the number of channels per unit area
- By decreasing the cell radius R and keeping the co-channel reuse ratio D/R unchanged
- Another way to increase capacity is to keep the cell radius unchanged and decrease D/R ratio.
- *Sectoring* increases SIR so that the cluster size may be reduced.
- First the SIR is improved using directional antennas, and then capacity improvement is achieved by reducing the number of cells in a cluster.
- So, increasing the frequency reuse it is necessary to reduce the relative interference without decreasing the transmit power
- The co-channel interference in a cellular system may be decreased by replacing a single omnidirectional antenna at the base station by several directional antennas, each radiating within a specified sector
- The factor by which the co-channel interference is reduced depends on the amount of sectoring used
- A cell is normally partitioned into three 120° sectors or six 60° sectors as shown in figure,

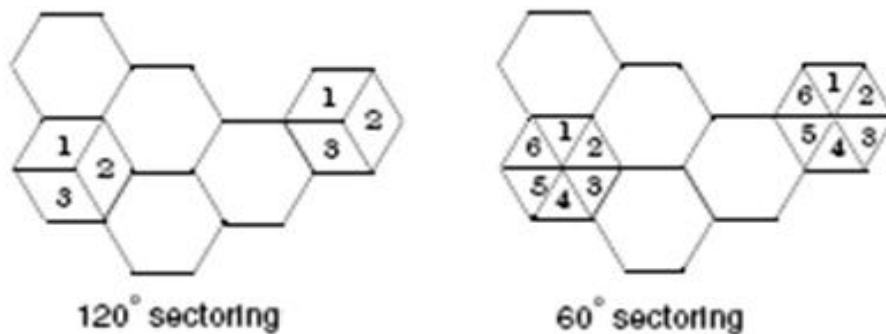

- In sectoring, the channels used in a particular cell are broken down into sectored groups and are used only within a particular sector.
- Assuming seven-cell reuse, for the case of 120° sectors, the number of interferers in the first tier is reduced from six to two.
- This is because only two of the six co-channel cells receive interference with a particular sectored channel group.

Disadvantages:



- Increased number of *antennas* at each base station
- As sectoring reduces the coverage area of a particular group of channels, the number of handoffs increases.

d) List any four features of third generation (3G) cellular standard. state various 3G standards. (TDMA and CDMA based).

Ans: (four features- 2mks, four standards- 2 mks)

1. The main feature of 3G technology is that it supports greater voice and data capacity and high data transmission at low-cost. 3G mobiles can operate on 2G and 3G technologies.
2. The second major feature is the security: 3G offers greater security features than 2G like Network Access Security, Network Domain Security, User Domain Security, Application Security.
3. This technology provides localized services for accessing traffic and weather updates. Video calls and video conference is another major feature in 3G mobile technology. These features reduces the communication barriers between people, that were not sacked even with mobile phones.
4. Data transfer rates are high and can support even live TV channels over phone.
5. Online media is another exciting feature in 3G mobiles.
6. 3G mobiles highly attract the music lovers as they can listen to music and watch videos online and can download huge files with in less time.

Standards-

- 1) CDMA 2000
- 2) WCDMA-UMTS
- 3) 3GTD-SCD
- 4) IMT2000

e) State and explain the various performance services offered by SS7 protocol.

Ans: (any four – 4 mks)



1. **Touch star** -It is also known as CLASS. It is a group of switch Controlled Services that provides its users with certain call management capabilities. It provides services such as call return, call forwarding, repeat dialing, call block, call tracing & caller ID.

2. **800 services** -It was introduced by bell System to provide toll-free access to the calling party to the services & database which is offered by private parties. Cost associated with the processing of calls is paid by the service subscriber.800 Service is offered under two plans:

- **800-NXX plan:** The first 6 digits of an 800 call are used to select the interexchange carrier (IXC)
- **800 database plan:** The call is looked up in the database to determine the appropriate carrier & routing information.

3. Alternate Billing Service & Line Information Database (ADB/LIDB)

These services use the CCS network to enable the calling party to bill a call to a personal number (third party number, calling card, or collect etc.) from any number

4. Performance of SS7

1) Performance of signalling network is studied by connection set-up time (response time) or the end-to-end Signalling information transfer time. The delays in the signalling point (SP) and the STP depend on the specific hardware configuration & switching software implementation.

2) Congestion control in SS7 networks:

With the increase in subscribers it is important to avoid congestion in the signaling network under heavy traffic conditions.SS7 networking protocols provide several congestion control schemes, allowing traffic to avoid failed links & nodes.

4. a) Attempt any THREE of the following:
spectrum for IMT-2000. State vision of FMT-2000 (four points)

12 i) State the radio

Ans:(any four spectrum- 2 mks, any four vision- 2 mks)

Spectrum-

3 Radio Spectrum for IMT- 2000 :

In 1992 for IMT-2000, the frequency bands 1885-2025 MHz and 2110-2200 MHz were allocated.

Uplink : 1885-2025 MHz (mobile satellite services)

Downlink: 2110-2200 MHz (mobile satellite services)

The terrestrial IMT-2000 networks will work in the following bands:

- Uplink : 1920 - 1980 MHz and downlink: 2110 - 2170 MHz, FDD with mobile stations transmitting in the lower sub-band.
- Uplink : 1885 - 1920 MHz and downlink : 2010 - 2025 MHz, unpaired for TDD operation.

In Europe the TDD band for uplink is from 1885-1900 MHz not available for licenses use of IMT-2000, this is used by cordless telephony (DECT).



Vision-

1. Common spectrum worldwide (1.8 – 2.2 GHz band)
2. Data rates of: 9.6Kbps or higher for global (mega cell), 144Kbps or higher for vehicular (macro cell), 384Kbps or higher for pedestrian (micro cell) and up to 2Mbps for indoor environments (pico cell)
3. Global seamless roaming .
4. Multiple environments, that are not only confined to cellular, but also includes cellular, cordless, satellite, LANs, wireless local loop (WLL).
5. Enhanced performance and security .
6. Wide range of telecommunications services (voice, data, multimedia, etc.)
7. Flexible radio bearers for increased spectrum efficiency

OR

- It supports multiple environments such as cellular, cordless satellite LAN"s.
- It provides global seamless roaming and service delivery across the INT 2000 networks.
- It supports the VHE (Virtual Home Entertainment) and UPT (Universal Personal telecommunication). It provides security and enhances performances.
- It provides global coverage by integrating the terrestrial and satellite systems.
- It provides 2 Mbps data rates for indoor environments. It makes use of Intelligent Networks capabilities.

ii) State the various services offered by GSM standard. Describe these services in detail.

Ans: (any four services- 2 mks, description – 2 mks)



Telephone Services:

Teleservices include
Standard mobile telephone
Mobile-originated
Base-originated traffic.
emergency calling
Fax
Videotext
Tele text,
SMS
MMS.

Supplementary ISDN services:

This service are digital in nature and include
Call diversion
Caller line ID
Closed user group
Call barring
Call waiting
Call hold
Connected line ID
Multiparty (Teleconferencing)
Call charge advice

This service also include the Short Messaging Service (SMS) which allow SM subscriber and BS to transmit alphanumeric pages of limited length (160 -7 ASCII characters) while simultaneously carrying normal voice traffic

iii) Compare GPRS with IS-136. (Any four points)

Ans: (any four- 4 mks)

	GPRS	IS-136
Date rate	171.2 kbps	
Channel BW	200 KHz	30 KHz
No. of voice channels	8 per carrier	3
Multiple access method	TDMA	TDMA
Modulation technique	GMSK and 8 PSK	$\pi/4$ DQPSK

iv) Define the term adjacent channel interference. State methods to reduce it?

Ans:-Defination with diagram- 2 mks, methods (two)- 2 mks each)

Adjacent channel interference: Interference resulting from signals which are close in frequency to the desired signal is called adjacent channel interference.

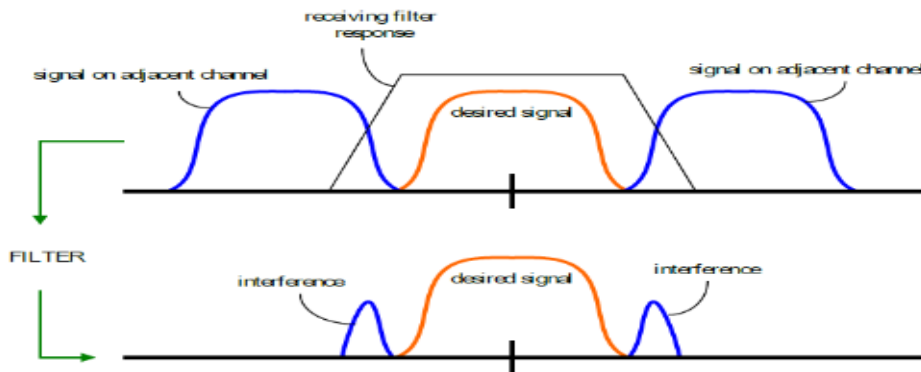

Adjacent channel interference results from imperfect receiver filters which allow nearby frequencies to leak in to pass band.

It is serious problem can be a particularly serious if an adjacent channel user is transmitting very close range to a subscribers receiver, while receiver attempts to receive a BS on the desired channel this is referred to as near far effect

Next channel interference:

Interference resulting from signal frequency which is immediately next to the desired signal frequency is called next channel interference.

Suppose the desired frequency of receiver is 90.3MHz. If it captures the frequency 91.3MHz transmitter then it results in next channel interference.

To reduce the interference: The adjacent channel interference can be reduced by

- 1) Careful filtering
 - 2) Careful channel assignment.
- There should be adequate frequency separation between the spectrums of the adjacent channels in a cell
 - If the frequency reuse factor is large or cluster size is small the adjacent channel at the base station will be too close to each other in the frequency domain and this will increase the interference.

b) Attempt any ONE of the following:

06

- i) Describe the concept of 'frequency reuse used in cellular systems. Also calculate the capacity for cluster size of 7 in cellular system which has 504 radio channels available for handling traffic. Calculate number of channels per cell. If number of clusters available in cellular systems are 15, then calculate capacity of system.

Ans: (frequency reuse-3 mks, solution – 3 mks)



Significance: Each cellular base station is allocated group of radio channels to be used within a small geographic area called “cell”

Base stations in adjacent cells are assigned channel group which contains completely different channels than neighboring cell.

By limiting coverage area to within the boundaries of cell, the same group of channels may be used to cover different cells that are separated from one another by distance large enough to keep interference level within tolerable limits.

The design process of selecting and allocating channel groups for all the cellular base station within a system is called **frequency reuse** or **frequency planning**.

Frequency reuse is important as the spectrum allocated for cellular transmission is limited and demand is increasing rapidly.

Number of channel = 504

Cluster size = 7

Capacity = M x K x N

No. of channels per cell = 504/7

= 72

For no. of clusters = 15

Capacity = 15 x 72 x 7

= 7560

ii) Draw SS7 protocol architecture and state the function of NSP of SS7.

Ans: (Diagram- 3 mks, Function- 3 mks)

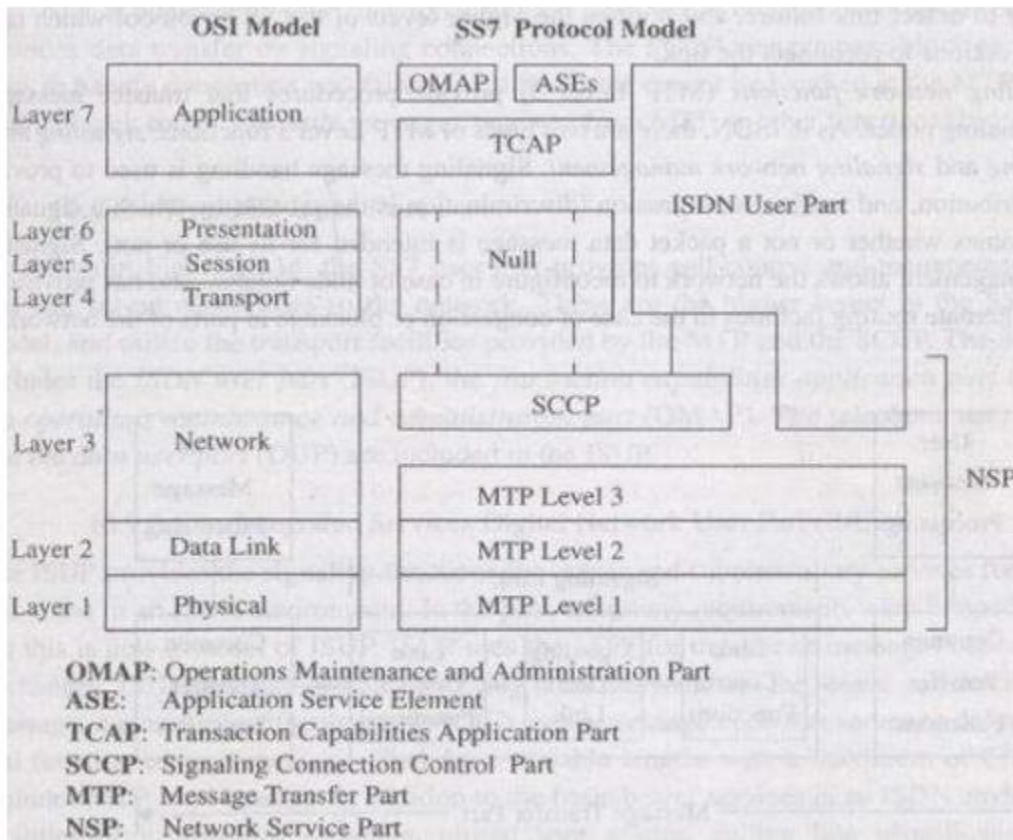

Function of NSP:-

- **Network Service Part of SS7:** The NSP provides ISDN with a highly reliable and efficient means of exchanging traffic using connectionless services. The NSP consists of Message transfer Part(MTP), Signaling Connection Control Part(SCCP).
 - The control messages are routed through the network for different functions such as set up, maintenance management, termination etc.
 - The control signaling is implemented using the packet switching technology network (PSTN).
 - The mode used is associated channel mode but the use of disassociated mode is also possible.
- The function of MTP is to ensure that signaling traffic can be transferred and delivered reliably between the end-users and the network.
 - **Signaling data link functions (MTP Level 1):** This level provide an interface to the actual physical channel (copper wire, fiber, satellite link etc) over which communication takes place.
 - **Signaling link function (MTP Level 2):** It provides a wide range of error detection and correction features.
 - **Signaling Network Function (MTP Level 3):** Provides procedure that transfer message between signaling nodes. It has two functions namely, Signaling Message Handling(SMH) and Signaling Network Management(SNM). SMH is used to provide routing, distribution and traffic discrimination.
 - **Signaling Connection Control Part (SCCP):** The SCCP provides enhancement to the addressing capabilities provided by the MTP.

5. Attempt any FOUR of the following:

16

a) Draw neat block diagram of transmitter unit of mobile handset. State function of APC loop and duplexer unit in unit.

Ans: - (block diagram-2 mks, function – 1 mks each)

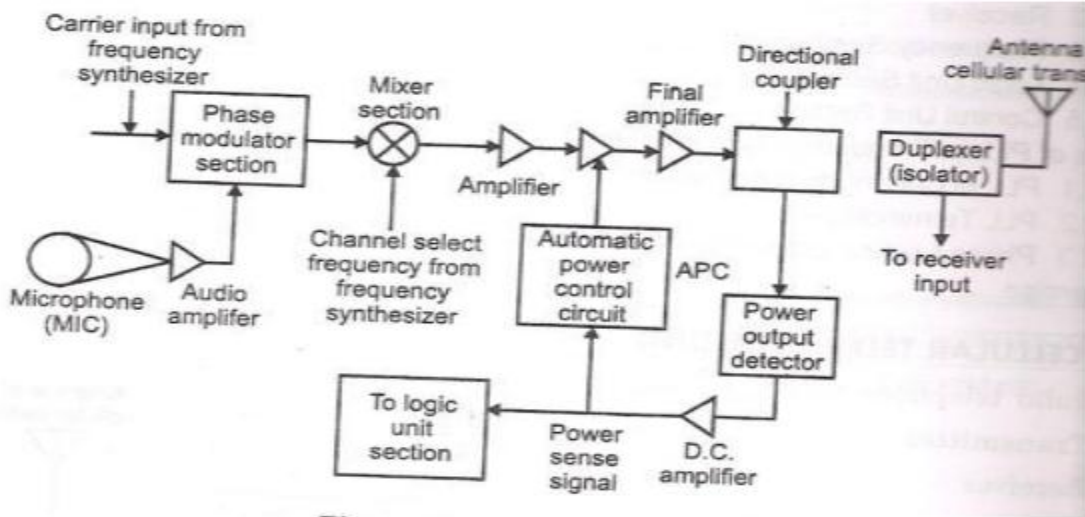

Automatic Power Control Circuit and DC amplifier:

The automatic power control circuit controls the o/p power of the transmitter automatically, with the help of power o/p detector & DC amplifier.

Transmitter o/p is fed to duplexer. Carrier i/p for the phase modulator & the local oscillator frequency signal for mixer are produced by frequency synthesizer.

Transmitter o/p power is controlled by cell site & MTSO.

Receiver picks up the special control signals & sends to APC that sets transmitter o/p power level.

OR

APC-

The receiver picks up the special control signals and sends them to the APC (automatic power control) circuit which sets the transmitter output power level to one of the possible eight levels.

Due to APC, the received signal from the cell site becomes adequately strong and the interference is reduced with the other stations in the same or adjacent cells.

Cellular telephone unit uses the full duplex mode of

Duplexer

The signal received by the antenna is isolated from the output stage of the transmitter with the help of a device called "Duplexer".

The duplexer will connect the received signal only to the cellular receiver input.

The duplexer output goes to the RF amplifier which boosts the level of input signal to a sufficient value and applies it to the first mixer.

b) Compare GSM standard with N-Amps standard with respect to following point.

- i) Generation
- ii) Channel bandwidth
- iii) Whether analog or digital
- iv) Data rate
- v) Frequency band. (Any four points)

Ans: (any four- 4 mks)

	GSM	N-Amps
Generation	2 G	Before 2 G
Channel bandwidth	200 KHz	10 KHz
Whether analog or digital	Digital	Analog
Data rate	270.833 Kbps	
Frequency band	1.85 – 1.99 GHz	824 - 894 MHz

c) Draw the forward channel structure of IS-95. Write function of each channel in it.

Ans:(structure- 2 mks, function- 2 mks)

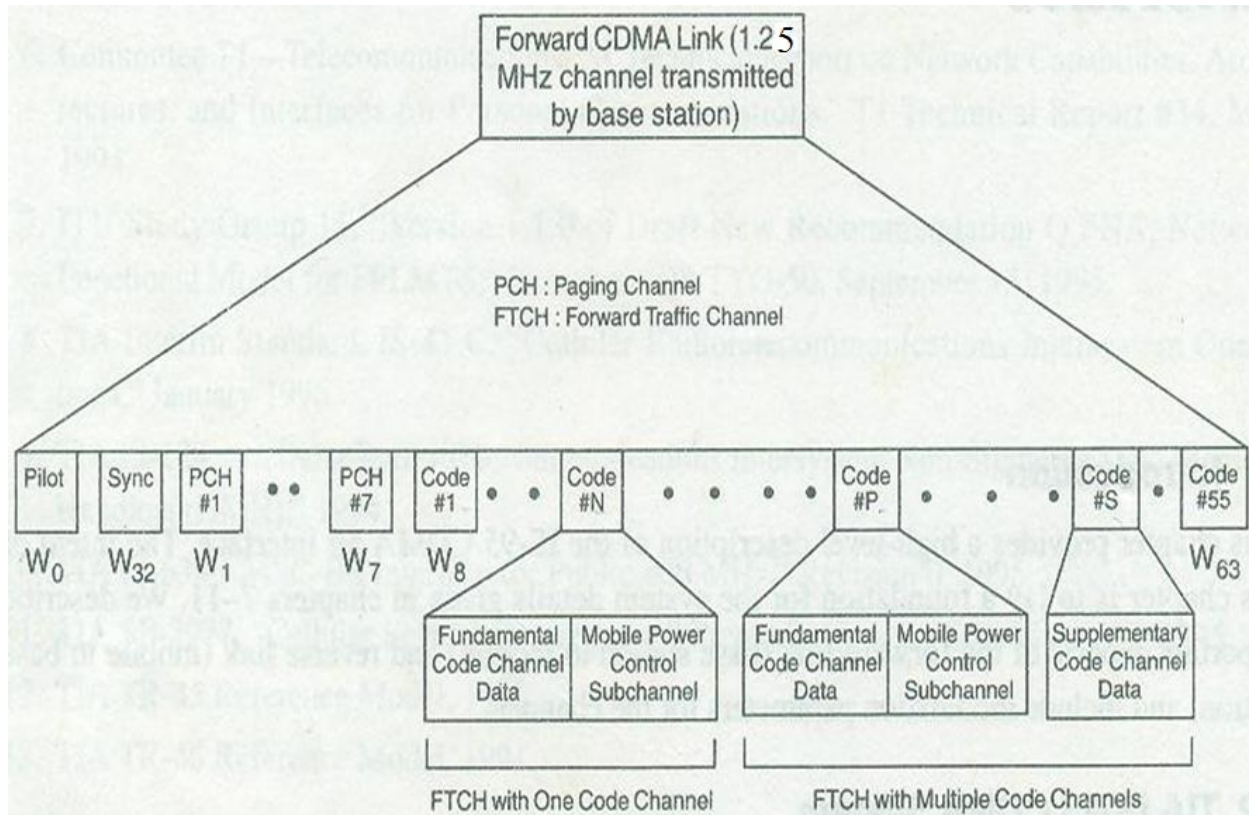

Forward channel is a communication channel used for transmission of information from BS to mobile station.

Pilot channel: This channel allows a MS to acquire timing for forward CDMA channel. Provides a phase reference for coherence demodulation. It provides each mobile with a means for signal strength comparison between BS for determining when to handoff.

Synchronization channel: The synchronization channel broadcasts synchronization message to the MS. The sync channel message parameters are **System Identification (SID)** and **Network Identification (NID)**

Paging Channel: The paging channel is used to send control information and paging messages from BS to the mobile and paging messages from BS to the mobile.

Forward Traffic channel: Information on the forward traffic channel includes the primary traffic (voice and data) secondary traffic (data) and signaling.

d) Draw neat block diagram of wireless local loop (WLL) network and state its importance.

Ans: - (diagram- 2 mks, importance- 2 mks)

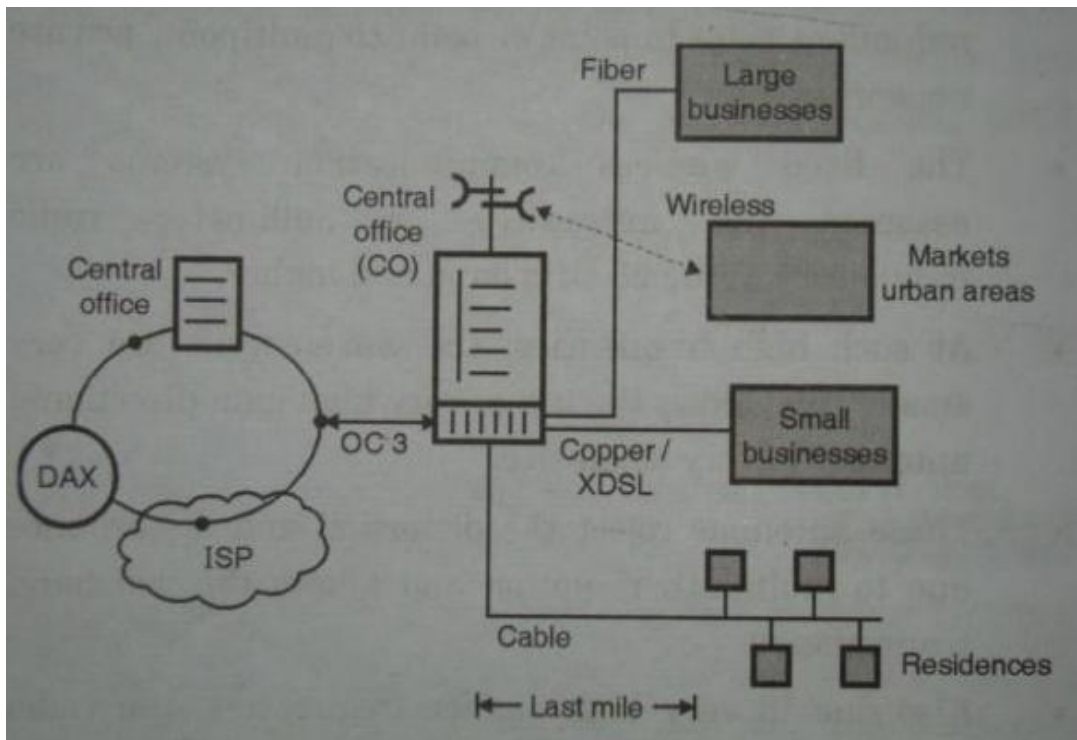

Importance:-

A great advantage of the wireless equipments however is that it can be deployed within a few hours. One more advantage of WLL technology is that we have to pay only once for the wireless equipment. After that there are no additional costs involved.

The WLL technology is capable of competing with the copper wire based Digital subscriber loop (DSL) technology which is growing very fast.

The WLL can greatly improve the telecommunication facilities and services in an inexpensive way.

e) State importance of the following terms:-

- i) Blockage
- ii) Voice call blockage



- iii) Voice quality
- iv) Word error rate

Ans: (each definition – 1 mks)

Blockage : There are two types of blockage

Set up blockage: To a mobile several calls can inter-collide simultaneously. If this no exceeds 10 then mobile is said to be blocked and this blockage is called as setup channel blockage.

Voice channel blockage: Simultaneously when many calls come in, calls are rejected because there are no voice channels available, this is called voice channel blockage.

- **Word error rate:** Word error rate (WER) is a common metric of the performance of a speech recognition or machine translation system.
Word error rate can then be computed as: $WER = \frac{S+D+I}{N}$
S is the number of substitutions, D is the number of deletions, I is the number of insertions, C is the number of the corrects, N is the number of words in the reference ($N=S+D+C$)
- **Voice quality:** Voice quality is signal to ratio and distortion ratio.
SINAD is usually expressed in dB and is quoted alongside the receiver RF sensitivity, to give a quantitative evaluation of the receiver sensitivity

f) Define the following terms.

- i) Control channels
- ii) Mobile station
- iii) MSC
- iv) Cell splitting

Ans: (each definition – 1 mks)

Control channel

It is defined as the radio channel used for the transmission of beacons such as call set up, call request, call initiation etc.

Mobile station:

It is defined as a station in the cellular radio service which is used when in motion at an unspecified location. Mobile stations may be held- held personal units (portables) or installed in vehicles (mobiles).

Mobile Switching Centre- (MSC): The MSC co-ordinates the activities of all the base stations and connects the entire cellular system to the PSTN. A typical MSC handles 100,000 cellular subscribers and 5,000 simultaneous conversations at a time, and accommodates all billing and system maintenance functions as well. Communication between the BS and mobiles is defined by a standard Common Air Interface (CAI) that specifies four different channels.

Cell Splitting:

- Cell splitting is the process of subdividing a congested cell into smaller cells, each with its own base station and corresponding reduction in antenna height and transmitter power.

6. Attempt any FOUR of the following:

16

a) Complete and identify the given block diagram and state function of block A and RSSI signal.

Ans: Complete diagram- 1 mks, identification- 1 mks, function of block A and RSSI Signal – 1 mks each)

Complete diagram-

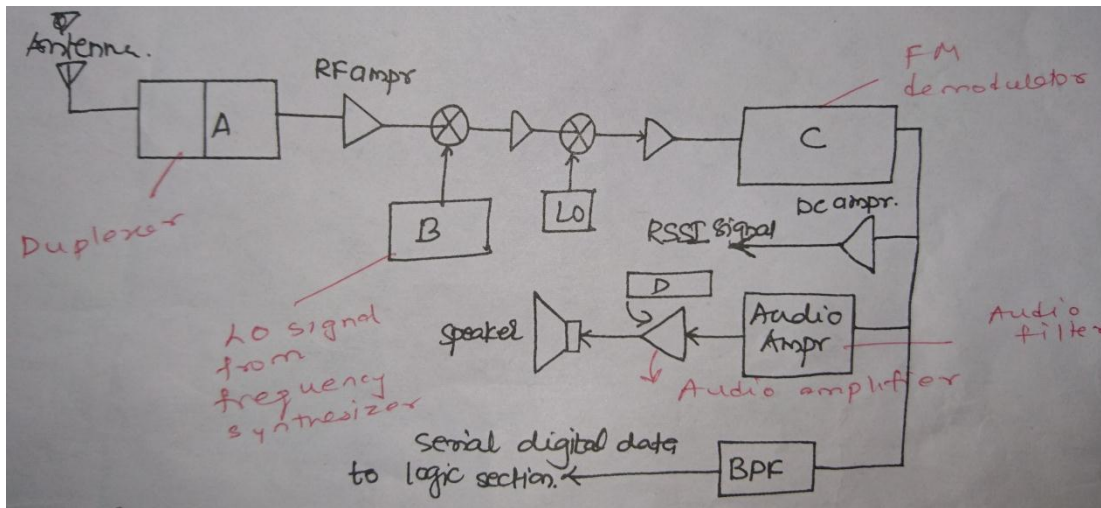

Identification-The given circuit is cellular receiver

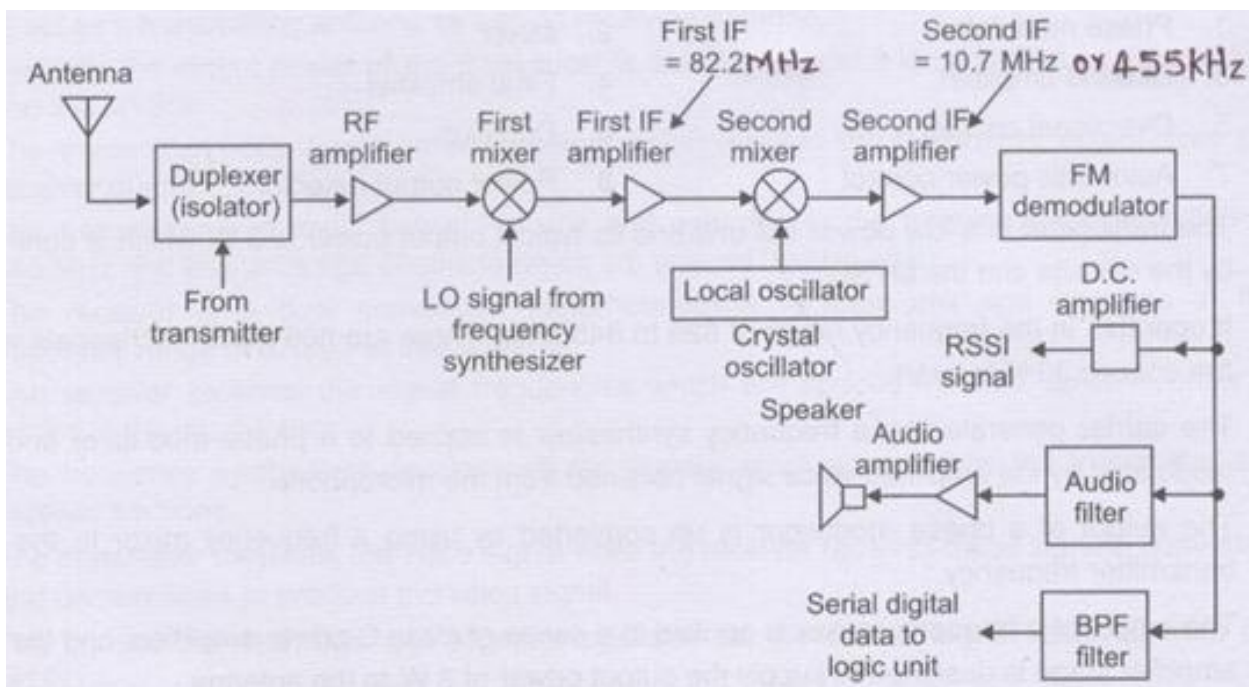

Function of-

Block A- Duplexer-The transmitter output is fed to a duplexer or isolator which allows the transmitter and receiver and receiver frequencies to share the same antenna.

RSSI Signal-

The demodulator output filtered and is also applied to a DC amplifier which produces a DC voltage indicating the strength of the received signal. This indicator is called as Received Signal Strength Indicator (RSSI). The demodulator output is also applied to a band pass filter (BPF) which selects out the control audio tones and digital control data signal which are sent by the cell site. These signal are then applied to the logic unit which produces the set and control signals for transmitter and receiver. The RSSI signal is sent back to cell site in order to help MTSO to monitor the received signal from the cell and decide about switching to another cell.

- b) Compare IS-95 standard with GSM system with respect to following points.
- i) Channel bandwidth
 - ii) Type of modulation
 - iii) SMS length
 - iv) Number of voice channels.

Ans: (Relevant comparison- 4 mks)

Points	GSM	IS-95
Channel bandwidth	200 KHz	1.25 MHz
Type of modulation	GMSK	QPSK /BPSK
SMS length	160	120
Number of voice channels	8 per channel	64 per channel

- c) Draw 4G wireless architecture and state any four features of 4G standard.

Ans: -(Architecture(any relevant diagram) - 2 mks, any 4 relevant features- 2 mks)

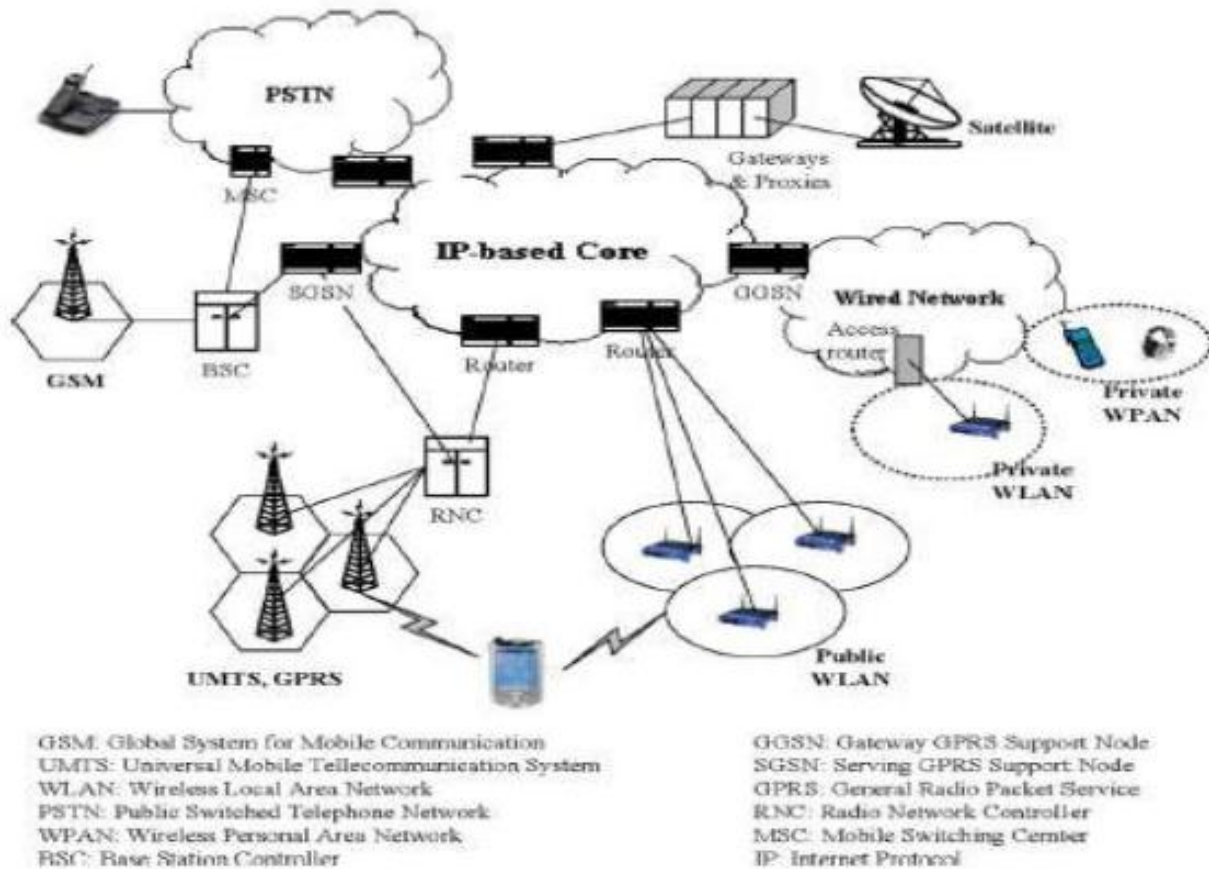

Fig: 4G Wireless Architecture

Features of 4G:

1. Faster and more reliable data rates than 100 Mb/s
2. It has a Low cost in comparison to other generations (1G,2G, 3G networks)
3. It supports Bluetooth , Wi-Fi,Wired and Wireless Ad Hoc Networking
4. It Supports for multimedia services like teleconferencing and wireless internet
5. They have wide bandwidth
6. 4G networks are completely packet-switched networks
7. They have high internet speeds.
8. Provide global mobility and service portability.
9. The network security is tight .

d) Draw block diagram of mobile unit and state function of each block. Also state two features of mobile hand set.

Ans:(Diagram- 1 mks, function of each block-2 mks, any two features-1 mks)

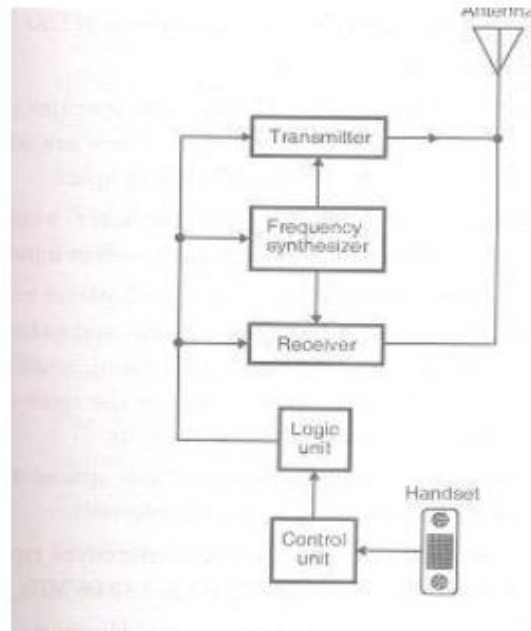

Transmitter: It is low power FM unit operating in the frequency range of 825 to 845MHz. There are 666, 30 KHz transmit channel. The carrier is furnished by a frequency synthesizer is a phase modulated by voice signal.

Receiver: The receiver is a dual conversion super heterodyne. The incoming signal frequency is down converted twice to frequency of 455KHz or 10.7MHMz with the help of mixer and IF amplifier stages. The signal is then demodulated deemphasized and filtered and given to loud speaker.

Frequency Synthesizer: This block generates all the signals used by transmitter and receivers. It uses standard PLL circuits and a mixer.

Logic Unit: This unit contains master control circuit for a cellular radio. It is made up of microprocessor with RAM and ROM and additional circuit used for interpreting signals from MSC and BS and generates control signal for the transmitter and receiver.

Control unit: The control unit contains the handset with speaker and microphone. The control unit is operated by a separate microprocessor that drives the LCD display and other indicators.

Features-

- 1) Typical o/p power is 3 W if mobile unit is mounted on vehicle
- 2) o/p power is only 500Mw if it is a handheld unit
- 3) transmitter is a low power FM unit operating in frequency range of 825 to 845 Mhz
- 4) It has 666 transmit channels which are spaced 30 Khz apart



e) List out any four key features of IS-95 CDMA system.

Ans: (Any Four relevant key features- 4 mks)

Key features of IS-95 CDMA system:

1. Diversity
2. Power control
3. Soft handoff
4. IS-95 system capacity
5. Soft capacity
6. Quality of service
7. Economics