



**WINTER– 2017 EXAMINATION**

**Subject Name: Audio Video Engineering Model Answer Subject Code:**

**17537**

**Important Instructions to examiners:**

- 1) The answers should be examined by key words and not as word-to-word as given in the model answer scheme.
- 2) The model answer and the answer written by candidate may vary but the examiner may try to assess the understanding level of the candidate.
- 3) The language errors such as grammatical, spelling errors should not be given more Importance (Not applicable for subject English and Communication Skills).
- 4) While assessing figures, examiner may give credit for principal components indicated in the figure. The figures drawn by candidate and model answer may vary. The examiner may give credit for any equivalent figure drawn.
- 5) Credits may be given step wise for numerical problems. In some cases, the assumed constant values may vary and there may be some difference in the candidate's answers and model answer.
- 6) In case of some questions credit may be given by judgement on part of examiner of relevant answer based on candidate's understanding.
- 7) For programming language papers, credit may be given to any other program based on equivalent concept.



Q1) Attempt any three:

12

a) Compare Woofer, mid range and Tweeter speaker(any four points)

Ans

(1M each point)

SR. NO.	PARAMETER	WOOFER	MID-RANGE (SQUAWKER)	TWEETER
1.	Definition	A woofer is a technical term for loudspeaker driver designed to produce low frequency sounds	A mid-range speaker is a loudspeaker driver that reproduces sound in the frequency range from 250 to 2000 Hz	A tweeter or treble speaker is a special type of loudspeaker that is designed to produce high audio frequencies
2.	Range of Frequency	16Hz to 500Hz	500Hz to 5KHz	5KHz to 20KHz
3.	Size & Physical Structure	Size is largest to match the impedance to the air.	They are of medium size, kept in between tweeter & woofer.	They process High frequency, hence their size is small. They are light in weight so that they can respond rapidly to applied signal.
4.	Weight	Heavier than tweeter & Squeaker	Heavy than tweeter & light in weight than woofer	Light in weight than woofer & Squeaker

b) Draw constructional details of Dish antenna .List any4specifications of dish antenna.

**Ans:(diagram:2m and Specification:2m)**

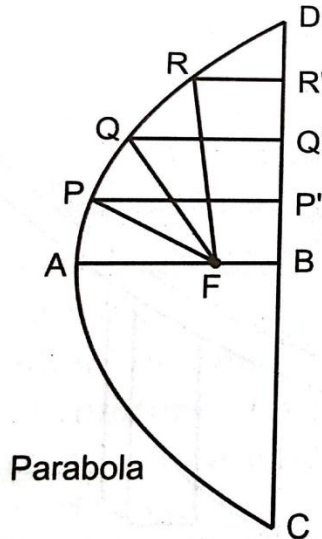

AF = Focal length of the parabola

**Specifications (any 2 )**

1. Size-8 feet.
2. Gain-36 dB.
3. Band-C-(3.7 to 4.2 GHz downlink frequency).
4. Look angle- 360 degree rotation in azimuth.18 to 90 degree rotation in elevation.
5. Offset angle-24.62 limit.
6. Focal length – 90 cm.
7. Elevation angle range = 17 to 90 limit
8. Azimuth angle = 0 to 360 degree
9. Aperture efficiency= 75%

**C) Define the terms: (2M each)**

**i)Interlace scanning:**

The scene is scanned rapidly both in the horizontal and vertical directions simultaneously to provide sufficient number of complete pictures or frames per second to give the illusion of continuous motion. Instead of the 24 as in commercial motion picture practice, the frame repetition rate is 25 per second in most television systems.

**ii) Aspect ratio:** The aspect ratio of an image describes the proportional relationship between its width and its height. The frame adopted in all television systems is rectangular with width/height ratio, i.e., aspect ratio = 4/3.

**Aspect Ratio= Width of the Screen/Height Of the Screen=4/3**

**d) Draw the block diagram of CD player.(4M)**

**Ans:**

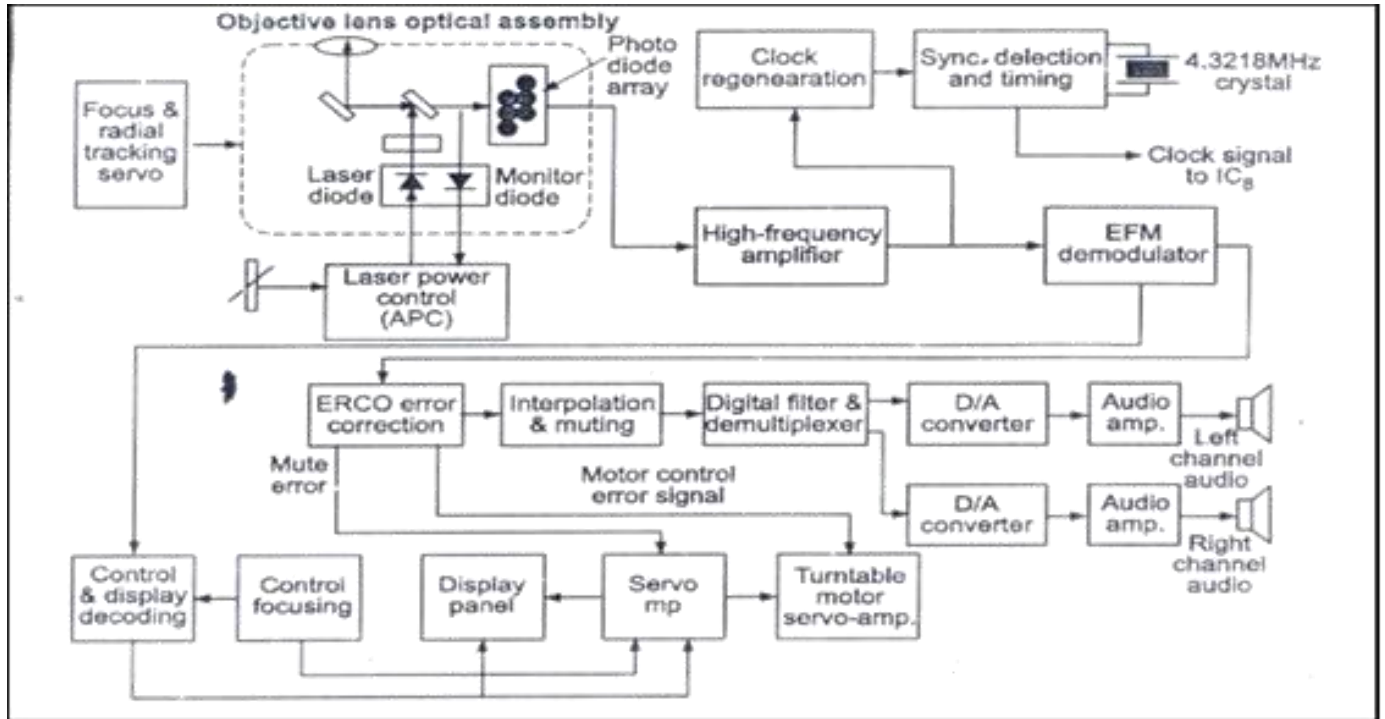

**B]Attempt any one:**

**6**

a) Draw block diagram of colour TV Receiver (PAL-D) and label it.(6M)

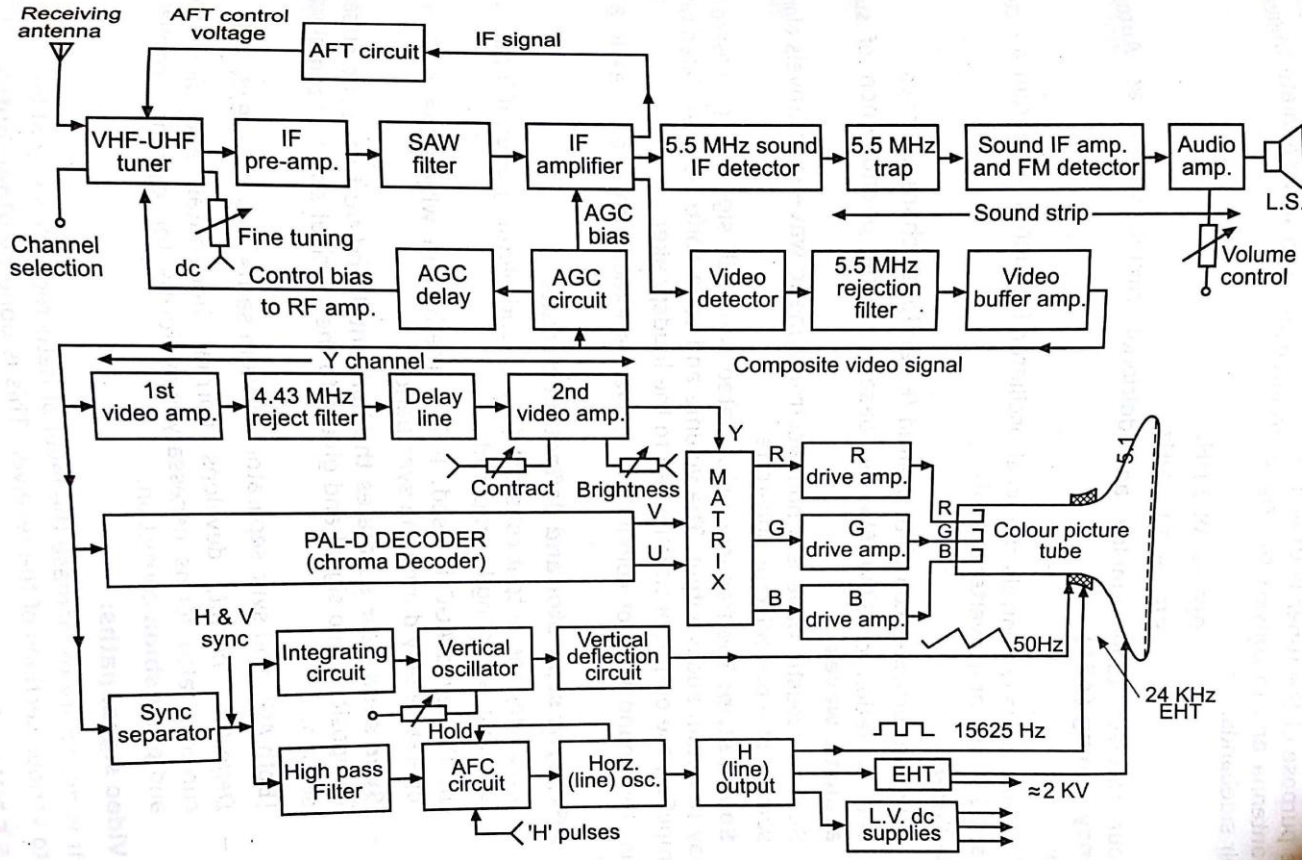

b) Draw EHT generation circuit using transistor and explain the operation. (Diagram: 3m explanation: 3M)

**Diagram**

:

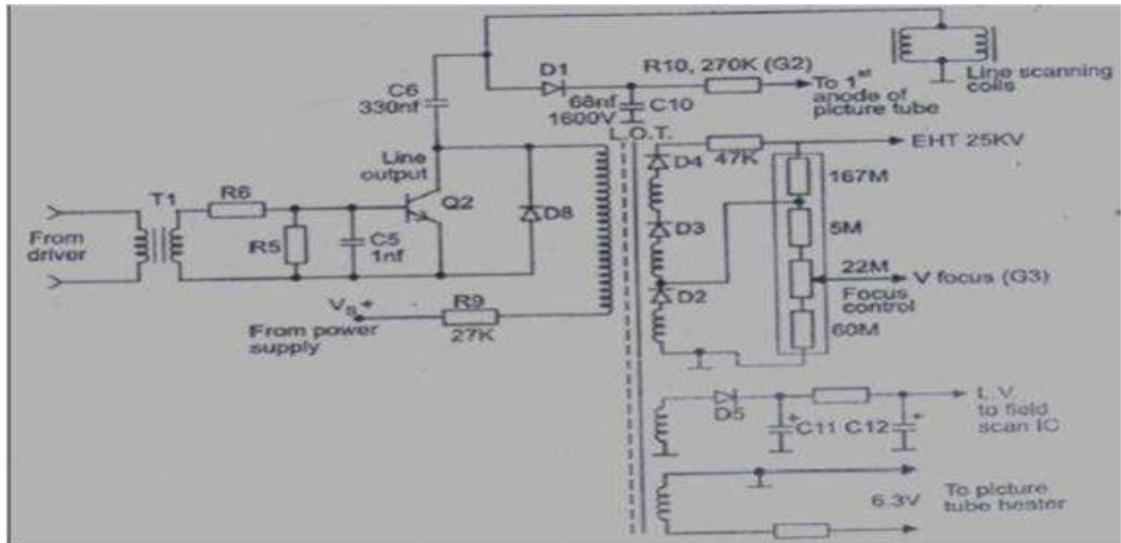

**OR**

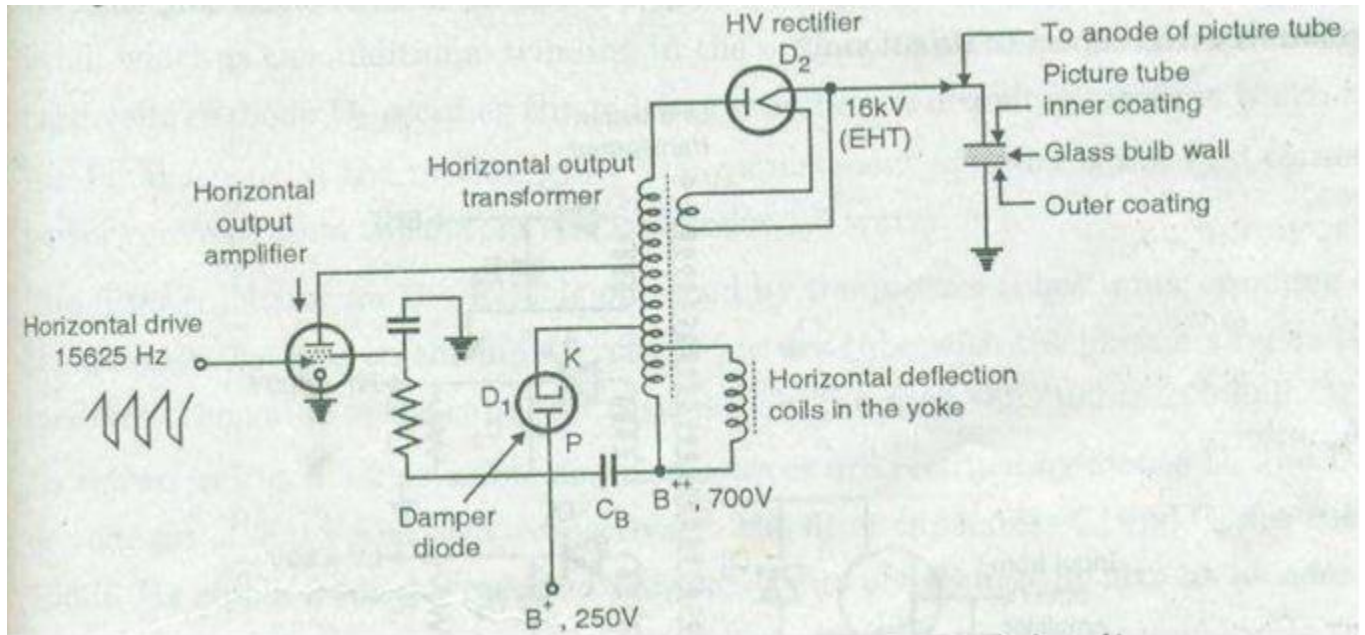

### Explanation

- Anode potential (G2) is obtained for screen grid separately at collector of Q2.
- This is rectified by D1 and then filtered by C10. Output DC voltage is 550 to 800 V. Any failure of G2 means no beam current and hence no spot is produced on screen.
- Focus anode (G3) potential needed is 6.5kV to 7.5kV. It is obtained from diode split winding (D2, D3 and D4). Each stage produces potential of 8kV.

Q2) Attempt any Four:

16

a) Draw Block diagram of PAL-D decoder system.(4M)

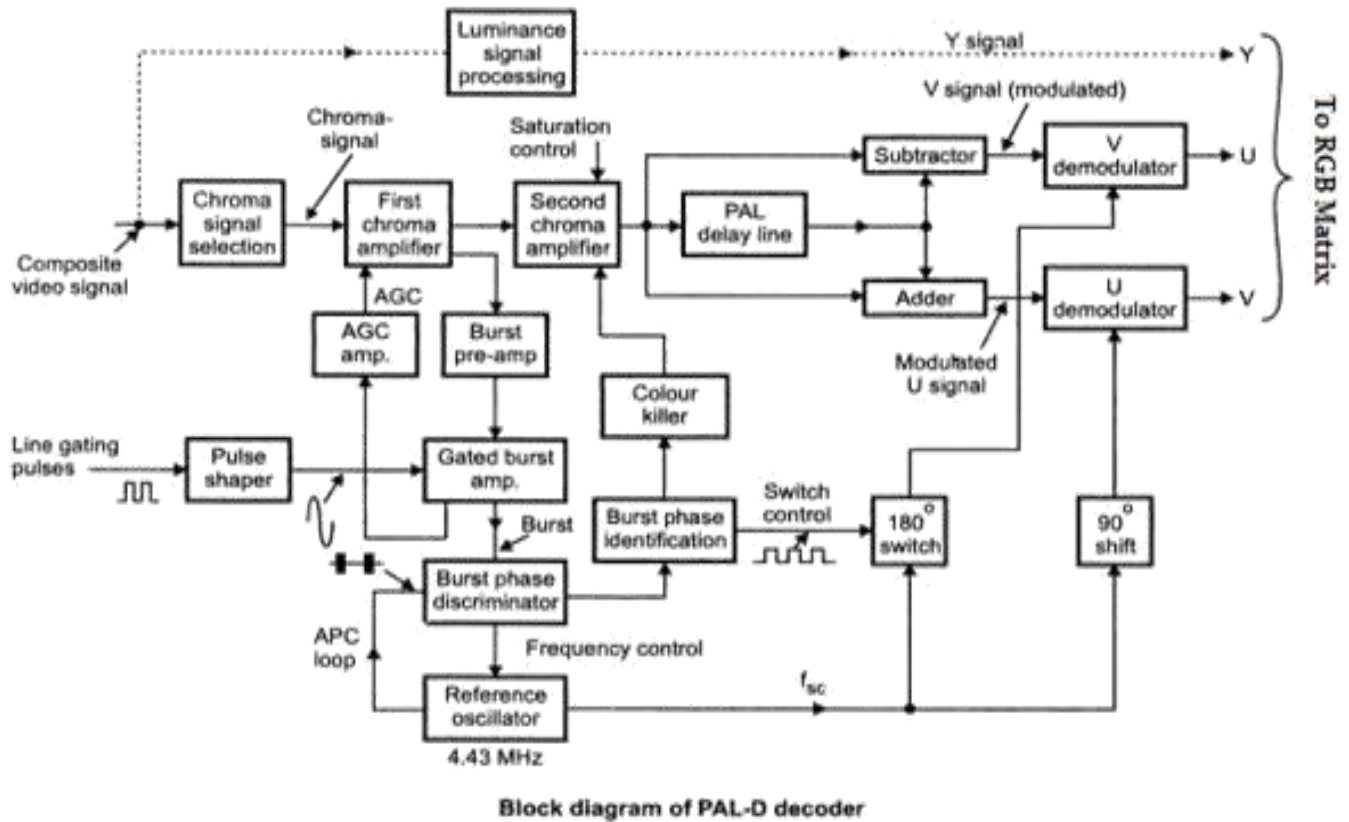

b) List the CCIRB standards for colour signal transmission and reception(4M any 8 points )





<u>Parameters</u>	<u>CCIR B standard</u>
Number of scanning lines/frame	625
Field (vertical) frequency	50Hz
Line(horizontal) frequency	15625Hz
Aspect ratio(width/height)	4:3
Horizontal trace time	52µs
Horizontal retrace time	12µs
Total scanning line lost in vertical retrace	64µs
Front porch	1.5µs
Back porch	5.8µs
Horizontal sync pulse	4.7µs
Colour sub carrier frequency	4.43MHz
Colour system	Phase Alteration by Line –Delay (PAL-D)
U signal(weighted B-Y)	<u><math>U=0.493(B-Y)</math></u>
V signal(weighted R-Y)	<u><math>V=0.877(R-Y)</math></u>
Total vertical blanking duration	1280µs or 1.280ms
Vertical sync pulse	160µs
Pre and post equalizing pulse	5 pulse each
Sync pulse top	100%
Blanking/pedestal level	75%
Black level	72-75%
White level	10-12.5%
Width of video signal	5MHz
Chroma signal bandwidth	-1.3MHz to +1.57MHz
Video IF	38.9MHz

c) Explain the working principle of LCDTV. (Diagram:2m explanation:2M)

**Working:-**

- LCD TV uses the LCD Display technology to produce images.



- LCD is a form of visual display technology that functions by sandwiching a layer of liquid crystals between two transparent electrodes or conductive surfaces.
- Liquid Crystals are specialized molecules that flow like liquids but polarize light like solid, crystalline structures.
- LCD technology works by selective passage of light, which passes through millions of individual LCD structures.
- These shutters are arranged in grids and constitute coloured filters, allowing only the RGB portion of the light to pass through white light are typically provided by a series of CCFLs (Cold Cathode Fluorescent Lamps), which are rear of the screen.
- Every single sub – pixel is formed by a shutter filter combination, and these sub – pixels blend together to form whole picture.

Diagram:

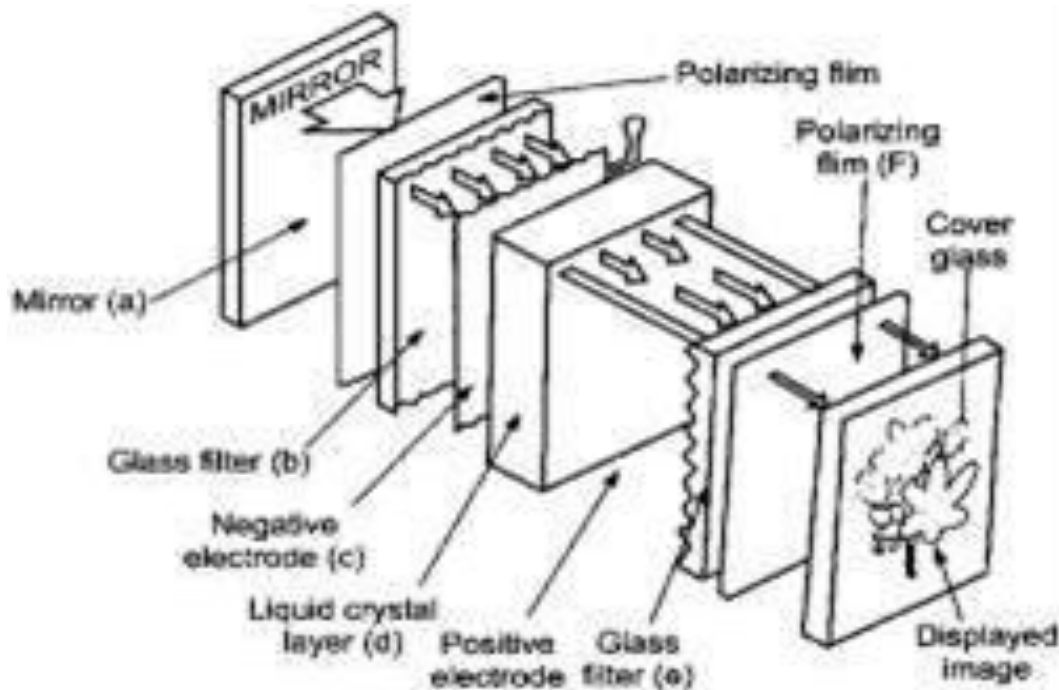



d) State any four advantages of vacuum fluorescent display.

Ans: (any four advantages – 1 mark each)

- 1) Displays the pitch of the channel, band etc.
- 2) Helps the listener to adjust the pitch of his interest by seeing the display.
- 3) Helps to know the voice band when using the karaoke system.
- 4) Uniform brightness, low cost etc.
- 5) In addition to ten numerals, the display can be used to show letters including punctuation.
- 6) It gives hexadecimal encoding for display the digits 0 to F.
- 7) To remove the ambiguity letter 'B' is small 'b' and number '8' is in 7 segment display, otherwise both would have looked same.
- 8) It can give short message giving status information in CD player like "no disc" or "error" etc.
- 9) The fluorescent numbers and messages can be seen in the dark also.

e) Describe NHK and MUSE system for HDTV. (2M each)

#### **HDTV:**

- MUSE stands for Multiple Sub-Nyquist Sampling Encoding and is an HDTV bandwidth compression scheme developed by NHK.
- It uses fundamental concepts for performance exchange in the spatio – temporal (transitory transformation) domain along with motion compensation to reduce the transmission bandwidth down to near about 10 MHz.
- The processed HDTV signal can be then transmitted using a single BDS channel.



Temporal Interpolation: In MUSE the luminance and colour information are sent by time multiplexed components (TMC) The colour information is sent sequentially with a time compression of four.

□ The TMC signal is bandwidth reduced means of 3 – dimensional offset subsampling pattern over a four – field sequence. The stationary areas of the picture are reconstructed by temporal interpolation of samples from four fields.

Spatial Interpolation:

□ For a moving picture area the final picture is reconstructed by spatial interpolation using samples from a single field. Hence moving portions of the picture are reproduced with one- quarter the spatial resolution of the stationary areas. The spatial frequency response for both stationary and moving areas of the picture is shown in figure below. The lack of resolution during movements of the entire scene as in case of camera panning, zooming or tilting is prevented by introducing spatial motion compression technique. A vector representing the motion of the scene is calculated for each field at the encoder. This signal is multiplexed in the vertical blanking interval and transmitted to the receiver.

□ In decoder, the read – out addresses of picture elements (pixels) from previous fields are shifted according to the information provided by the motion vector so that the data can be processed in still – picture mode.

□ These two modes of interpolation, the inter – frame processing for stationary pictures and infra field averaging for moving portions of the picture are switched by detecting the moving areas at the decoder.

□ Audio transmission is done by 4 – phase DPSK which is multiplexed with the processed video signal in the vertical blanking interval after frequency modulation of the transmission carrier by the video signal.

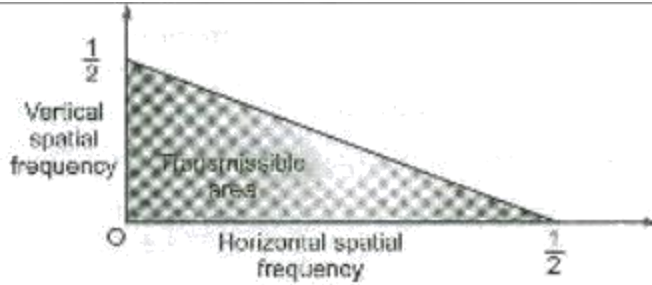

(a) For Stationary Portion of the Picture (Temporal Interpolation)

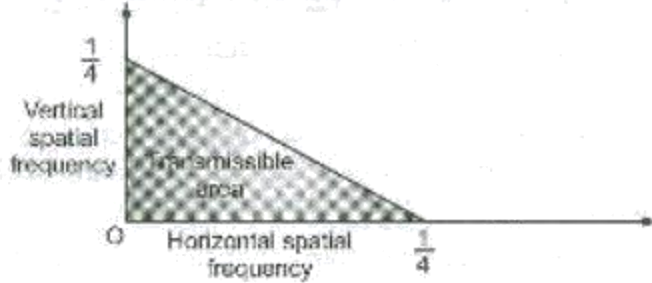

(b) For Moving Portion of the Picture (Spatial Interpolation)

f) Draw 5 point circuit diagram for graphic equalizer. (4M)

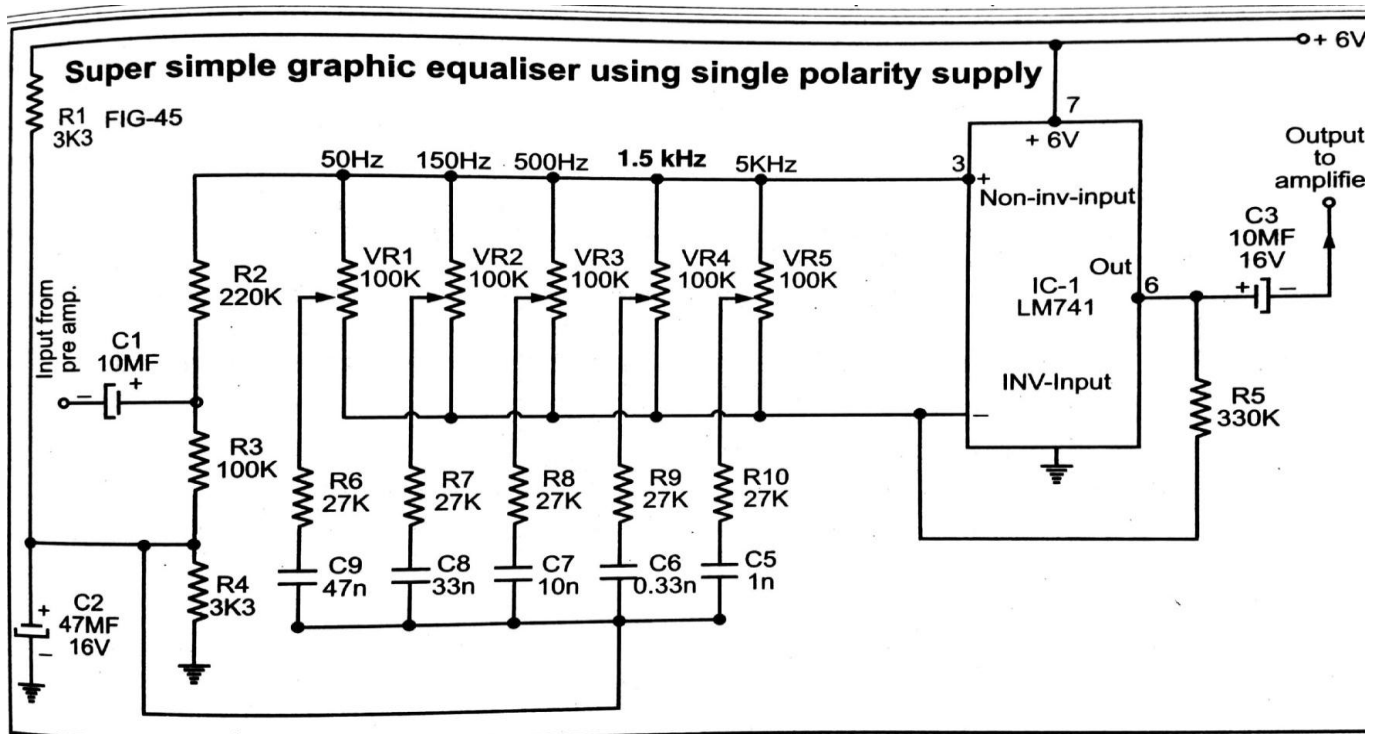

OR

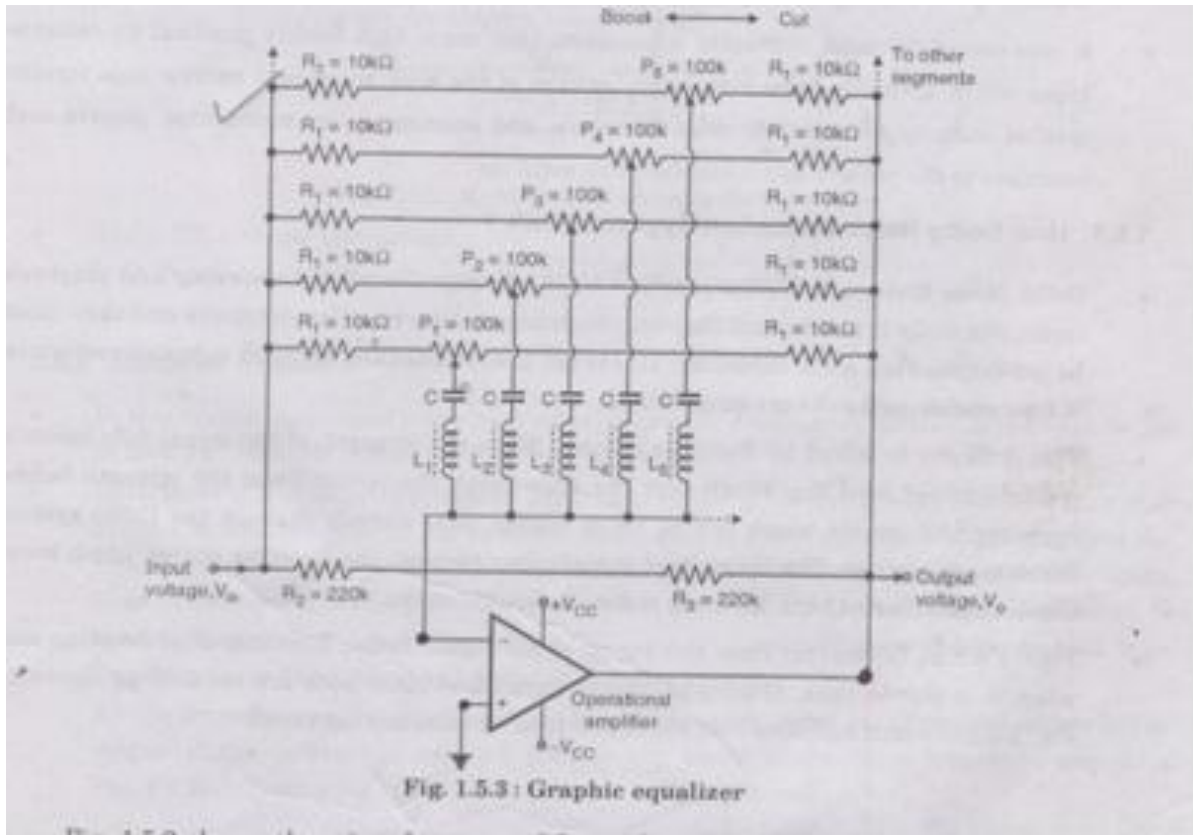

Q3) Attempt any four:

16

a) Describe The Architecture Of Cable TV Network. (Diagram:2m explanation:2M)

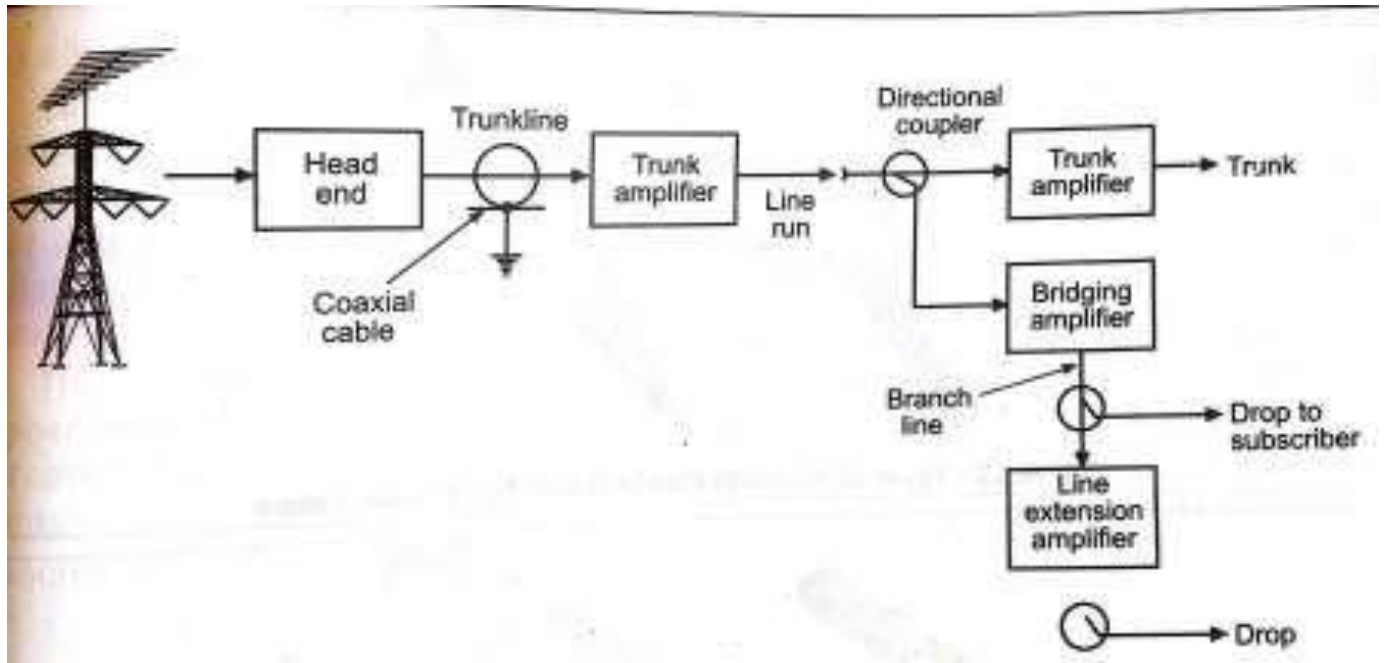

Types of amplifiers used in cable TV distribution are

1. Trunk amplifier 2. Bridging amplifier 3. Line Amplifier

1. Trunk amplifier :

There are losses in cable :DC loss ,Skin effect loss and dielectric loss. These losses increase in proportion to Square root of frequency. at the high VHF ,the loss may be double of loss at low VHF Hence the trunk amplifiers (Gain =20db to 30db) are inserted at regular intervals along the trunk route to make up for cable losses .

2. Bridging amplifier :

A bridging amplifier is for a branch from the main trunk to feed a particular neighborhood in the cable system. There is a bridge amplifier to act as a bridge between the trunk line and the branch line it takes care of impedance mismatch



caused by the connection with the trunk line and compensates the loss in the trunk line up to the point of connection. Gain of amplifier is 20 to 30 db.

### 3.Line Amplifier:

Branch lines are shorter in length, but they also need amplifier of 20 db to 30 db gain at suitable intervals .when a branch line is extended an amplifier becomes necessary and hence, it is also called as line extender.

b)Draw the ckt diagram of Acc amplifier and explain its working. (Diagram:2m explanation:2M)

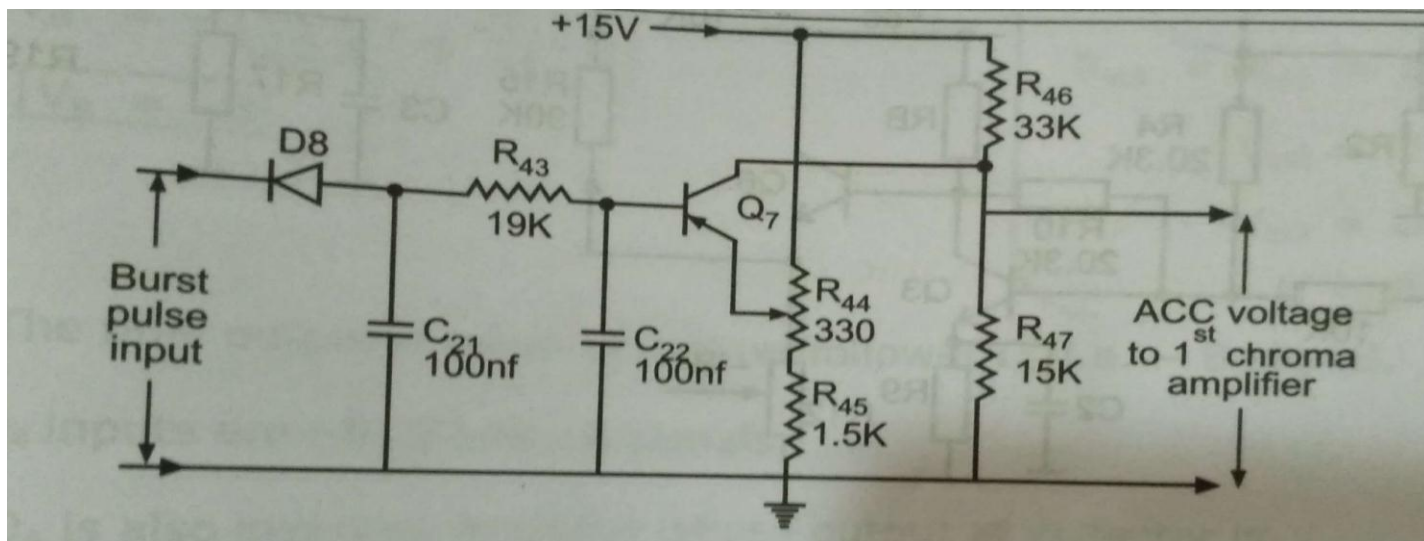

Burst pulse is fed to ACC amplifier diode D<sub>8</sub> and R<sub>43</sub>, C<sub>21</sub> and C<sub>22</sub> forms half wave rectifier and filter circuit

It provides negative DC voltage which is proportional to amplitude of received signal.

Output of Q<sub>7</sub> is positive voltage which changes with amplitude of Chroma signal. This voltage normally 7 volt .

It is given to 1<sup>st</sup> Chroma amplifier to control its gain. Purpose of  $R_{46}$  and  $R_{47}$  is to obtain correct steady bias for 1<sup>st</sup> Chroma amplifier.

$R_{44}$  provide adjustable reverse bias for  $Q_7$  to delay conduction until the Chroma signal exceeds the given threshold.

c) Define pre emphasis and de-emphasis. (2M each)

Pre emphasis:

If the higher frequency component is artificially boosted at the transmitter and correspondingly cut at the receiver, and improvement in noise immunity could be expected.

This boosting of the higher modulating frequencies, in accordance with a pre-arranged curve is termed as pre emphasis.

De-emphasis:

The compensation of attenuation of high frequency component for proper reproduction of modulating signal, at the receiver which are already boosted up at the transmitter is known as de-emphasis.

d) Explain the functions of front panel controls of CD player. (Diagram: 2M explanation: 2M)

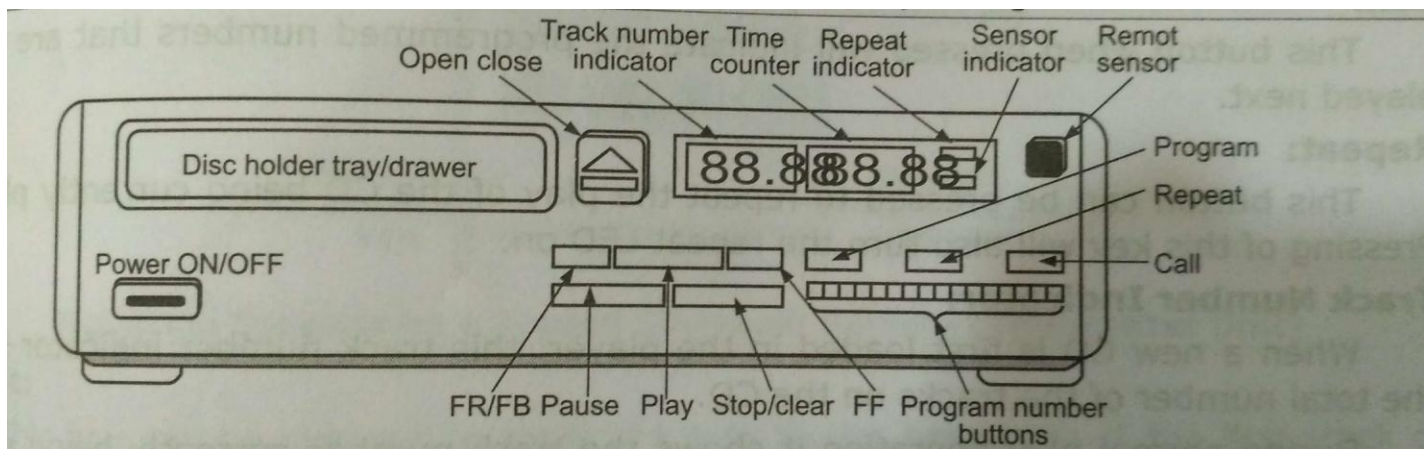



**Play:** Play button can be pressed to play all the tracks on the CD placed in the player pressing of the play button will start the playing of the CD from the track one and continue till the last track is reached

**Pause:** Pressing of the pause button can be used to suspend the playing operation temporarily. During the pause, the motor keeps on rotating the disk but the reading mechanism stays at the same place and the sound output is muted.

**Stop/Clear:** When the stop or clear button is pressed the play stop, the disc stops spinning and the pickup will return to starting of the disc. This will also clear any program in the memory of the CD player.

**Program:** The CD player can be programmed to play the tracks on the disc at the different order than the normal serial order, by selecting the required track and pressing the program button.

**FF/FB or FF/FR:**

The FF (Fast Forward) and FR (Fast Reverse) or FB (Fast Back) can be used to quickly reverse or forward the playing of current track.

**Call:** This button when pressed will indicate the program numbers that are to be played next.

**Repeat:** This button can be pressed to repeat the play of the CD being currently played, pressing of this key will also turn the repeat LED on.

e) List TV channel allocation for Band I and Band III (2M EACH)



<b><i>Band</i></b>	<b><i>Channel No.</i></b>	<b><i>Frequency range</i></b>
BAND I (41-68 MHz)	1	41–47 (not used)
	2	47–54
	3	54–61
	4	61-68
BAND III (174-230 MHz)	5	174–181
	6	181–188
	7	188–195
	8	195–202
	9	202–209
	10	209–216
	11	216–223
	12	223–230

Q4A) Attempt any three

12

a) Explain/ Define the following terms related to TV:

**1. Hue**

**(1 Mark)**

This is the predominant spectral color of received light which means it is the actual color seen by the eye. Red, Green, Blue, Yellow, Magenta, represent different in the visible spectrum.

**2. Luminance:**

**(1 Mark)**

Luminance is the amount of light intensity or the total amount of light energy that is received by the eye irrespective of the color of light. In monochrome TV, better lighted parts have more luminance than dark areas and different colors have shades of luminance.

**3. Bandwidth of color signal:**

**(1 mark )**



The color sub carrier frequency is restricted to about  $\pm 1.2$  MHz around the sub carrier. The brightness signal is transmitted with full frequency bandwidth of 5 MHz for maximum horizontal details in mono chrome.

#### 4. Saturation

(1 Mark)

**It** represents the spectral purity of a color light. It is the amount of white light that is mixed with a color.

A fully saturated color will have no white light mixed with it.

For example, a Pure Red without White is a saturated color.

b) Define the term positive modulation. List disadvantages of negative modulation (2M-Definition 2M-any 2 Disadvantages)

#### Positive modulation:

When increase in brightness of picture results in an increase in amplitude of modulated envelop it is called positive modulation.

Demerits:

- 1) Effect of noise modulation on synchronization
- 2) Picture tube needs positive polarity between control grid and cathode
- 3) Horizontal stabilizing circuits area must noise pulse going in blanking level causes synchronization trouble.
- 4) AGC reference level is higher than positive modulation because in negative modulation blanking level is 75% and sync pulses level at 100% are used in AGC reference level.

c) With help of neat sketch explain CD pickup assembly. (Diagram: 2M explanation: 2M)

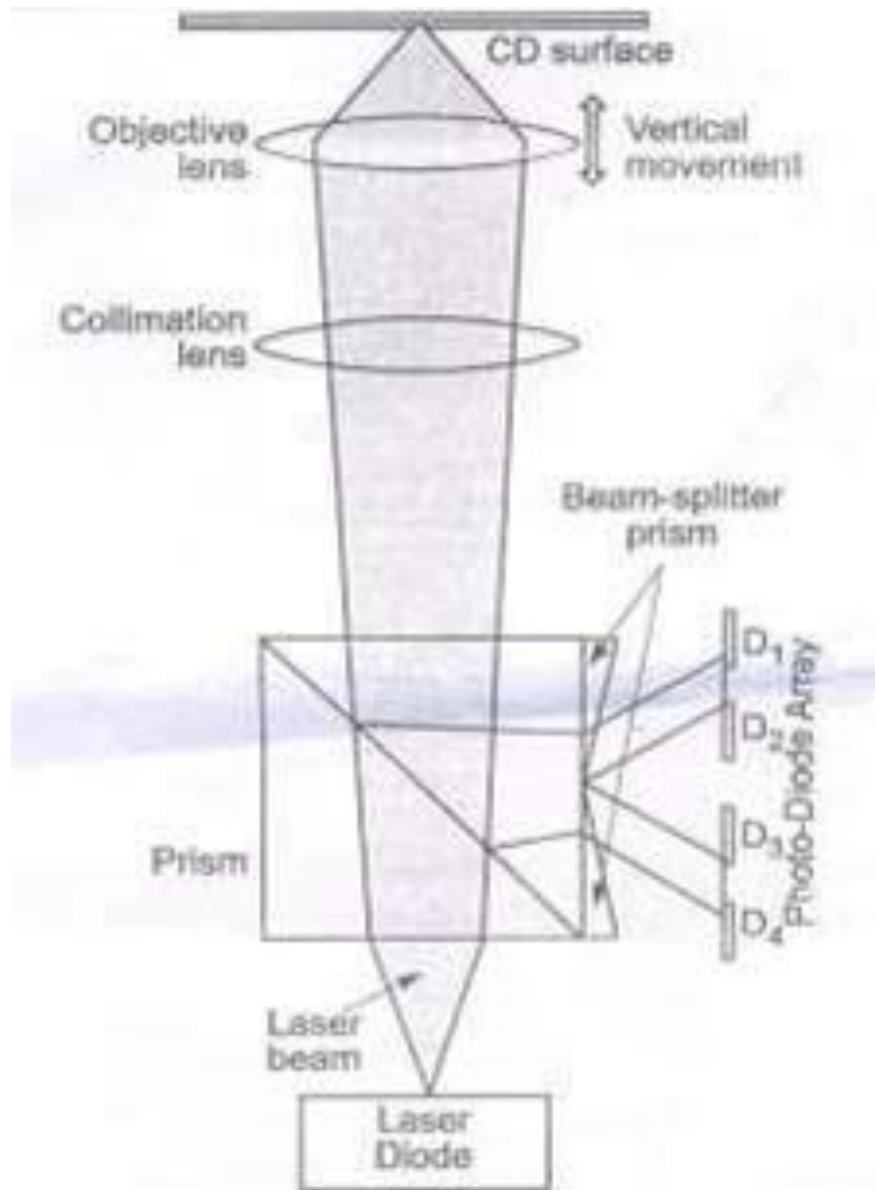

Explanation of Pick up assembly

The pick-up assemble consist of –

- A low power laser diode to illuminate the CD tracks.





- Lens and prism arrangement to direct the laser beam to the CD surface and to direct the reflected laser beam towards photo-diode array.
- A photo diode array to obtain data, focus and tracking signal from the reflected laser beam.

Focus and tracking coils to focus the beam to the CD surface and to move the assembly to proper track across the disc surface.

### **Optical arrangement in a single-beam radial tracking pick-up assembly:**

- In the optical pick-up unit, the laser diode emits laser beam from a small point

into an elliptical or conical distribution. This beam is passed through various prism and lens to form a very small diameter light beam on the disc surface at the center of the track.

- The objective lens is controlled by the tracking and focusing coil to keep the beam focused on the CD and to keep the condensed beam at the center of the track.
- This laser beam is reflected back by the flat area and the pits on the disc surface. This reflected beam is applied to a group of photo-diodes through objectives lens, collimator lens and some prism arrangement.
- These photo-diodes induce voltage according to the reflected beam falling on it. Focus error and tracking error voltage generated by this photo-diode array is applied to the tracking and focusing coil to control the objective lens and data signal generated by this photo-diode array is sent to an amplifier to amplify the data signals
- picked-up from the disc. Finally, the output from the amplifier is processed to produce the audio signal stored on the disc surface.

d) Explain working principle of two way and three way attenuator/connector required for dish antenna. (2M EACH)

Three way connector:

Three way connector or splitter are actually combination of two way splitters. A three way line splitter consists of a two way line splitters which one of the branches being split again as shown in figure.

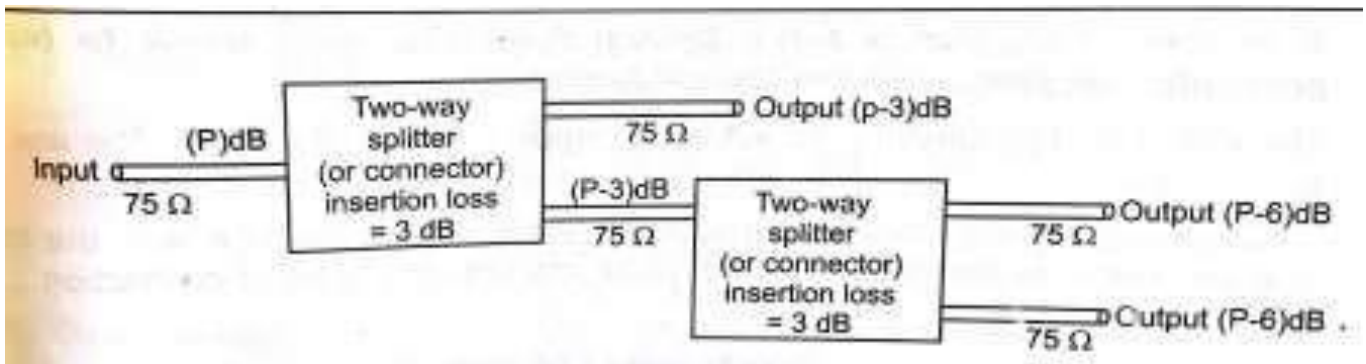

Two way connectors :

While dividing a cable TV transmission line, special devices are used to maintain necessary impedance matching.

These devices are known as line splitters or simply splitters. If the splitting is done from one input to two outputs, it is known as two way splitters. These are so designed as to present a 75 ohm characteristic impedance  $Z_0$  to all the branches of the line.

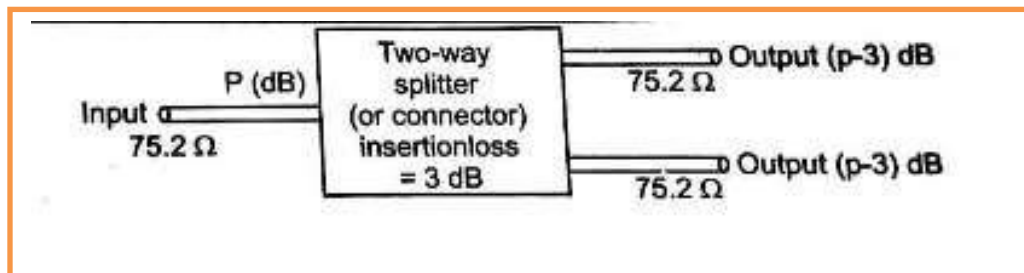

B) Attempt any one:

6

a) Draw the circuit diagram, of chroma signal amplifier and explain same ckt.

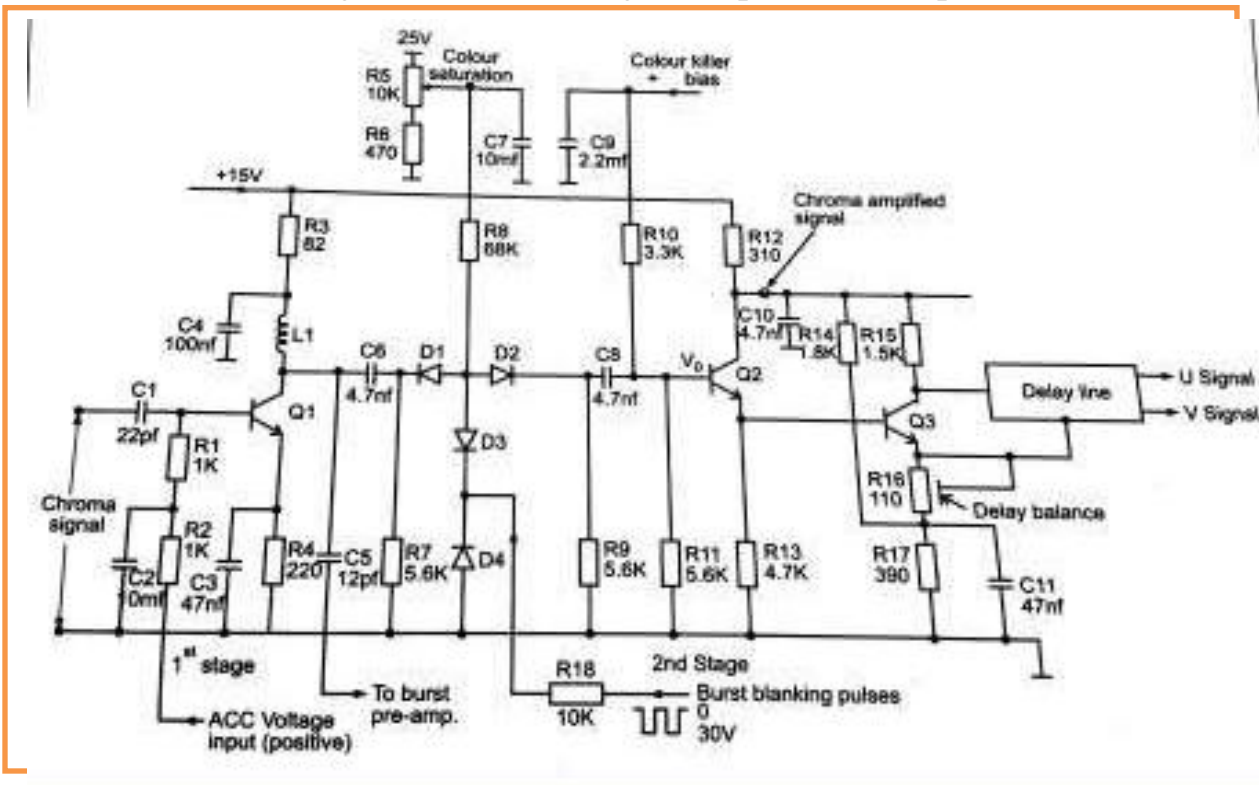

Color saturation control circuit:

Function of saturation control circuit to form variable attenuator to change magnitude of chroma signal which is fed to U and V demodulator. Attenuator consists of diodes D1, D2 with resistors R7, R9 and variable DC voltage obtained from DC source through resistor R5. Chroma signal is applied to the saturation control via C6 and taken out by way of C8. These two capacitors are short for high frequency chroma signal but prevent any DC flow through them.

Burst Pulse Blanking:

The function of diodes D3, D4 and resistor R18 shown in the figure of chroma amplifier is to prevent color burst pulses from getting through the second stage of the chroma amplifier.

If allowed to pass through, these would get demodulated at the U and V demodulator along with Chroma signal and causes positive pulse at V demodulator and negative pulse by U demodulator both coincide with burst pulse. This occurs during back level Hence blanking level should be higher than these pulse to avoid its visibility during fly back period.

Color killer control:

Upper end of R10 is connected to positive voltage generated by color killer circuit on rectification of burst pulse. When

Color signal is received, bias voltage is 12 volt. This makes Q2 on and ensures flow of chroma signal to Q3.

When monochrome signal is received bias applied to R10 becomes 2 volt. It is not enough to turn on Q2. Thus no signal is fed to Q3 in absence of color signal.

b) Draw the composite video signal, label each section and define pedestal height and colour Burst. (Diagram: 3M definition: 1.5M each)

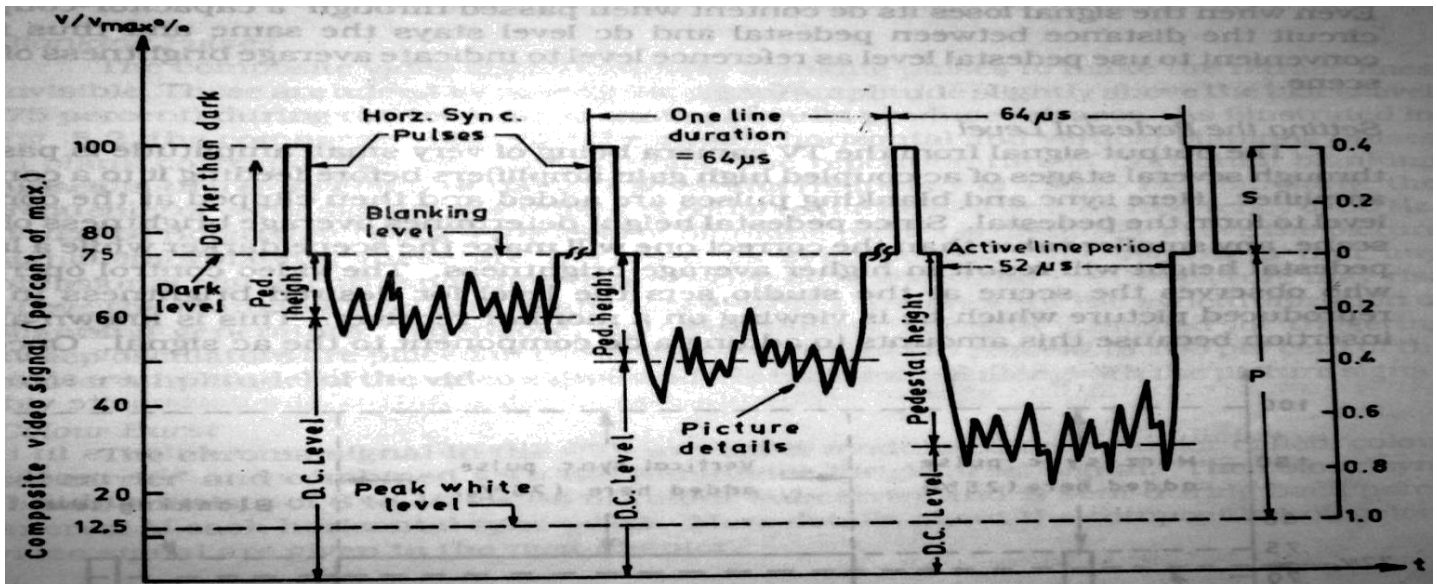

**Pedestal height:** The pedestal height is the difference between the pedestal level and the average value (dc level) axis of the video signal.

**Colour Burst:**

The sub carrier is suppressed at the modulated signal ,it is necessary to generate it in the receiver for demodulation of colour signal .this signal generated must be of exactly same frequency and phase as that of the transmitted.

To ensure this,short wave of 8 to 10 pulse called the colour burst is sent to the receiver along with sync signals

Q5)Attempt any two:

16

a)Describe Construction and working principal of plumbicon camera tube.  
(Diagram:4M explanation:4M)

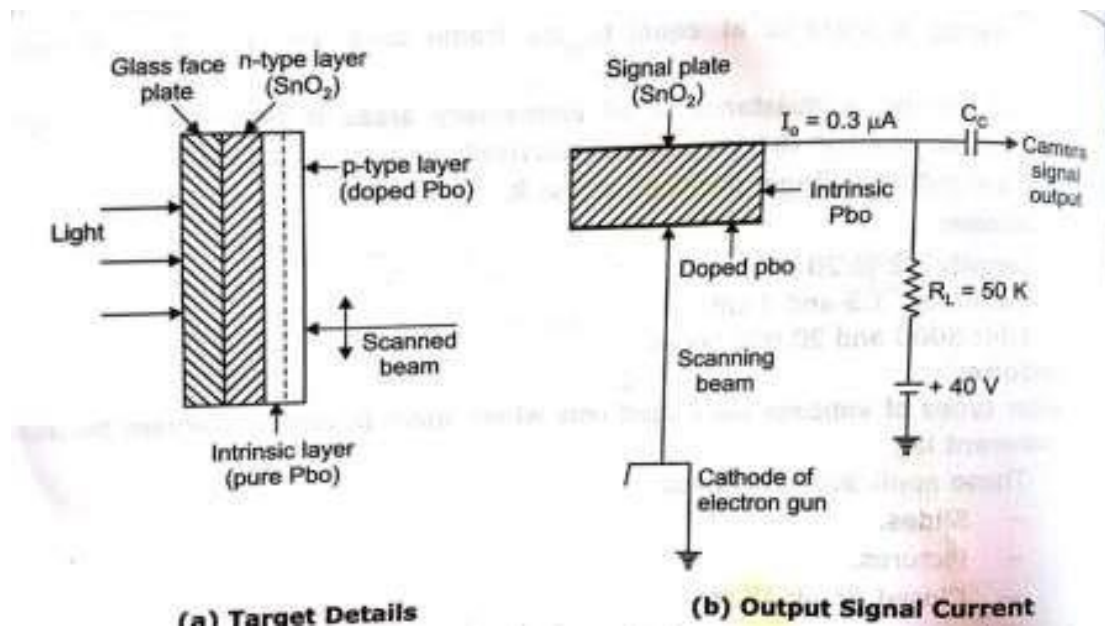



### **Principle:**

Plumbicon camera tube works on the principle of photo conductivity ,where the resistance of target material shows a mark decrease when exposed to light .

### **Construction:**

Focus and deflection and both obtained magnetically

Its target operates as aP-I-N semiconductor diode

The inner surface of the phase plate is coated with a thin transparent conductive layer of TIN oxide ( $\text{SnO}_2$ ).

This forms a strong N type layer and serves as a signal plate of the target

Photo conductive layer of pure lead monoxide is deposited on the scanning side of this layer which is intrinsic or I type finally the pure PbO is doped to form a P type semiconductor on which the scanning beam lands

### **Working:**

In the plumbicon,each element serves as a capacitor in series with a reverse bias light controlled diode.

In the signal circuit, the conductive film of PIN oxide is connected to the target supply of 40V through an external load resistance  $R_1$  to develop the camera output signal voltage

Light from the scene being televised is focused through the transparent layer of TIN oxide on the photo conductive lead monoxide .

Without light the target prevents any conduction.

Because of absence of charge carriers there is no output current.

The incidence of light on the target results in photo excitation of a semiconductor junction between PbO and dopped layer

The resultant decrease in resistance causes flow of signal current which is proportional to the incident light of each photo element.

b)Draw and describe working of db meter. (Diagram:4M explanation:4M)



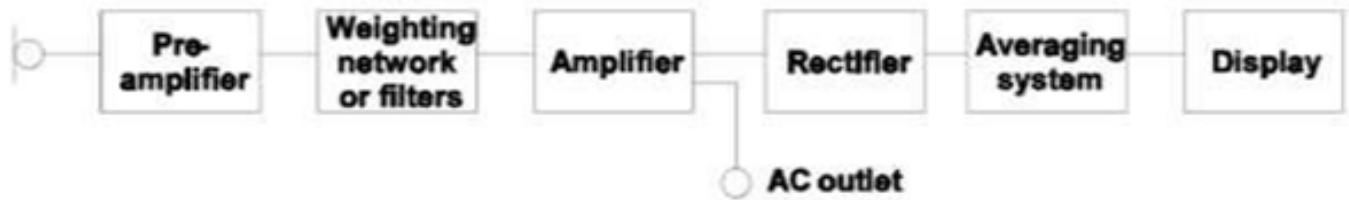

The two main characteristics are:

1. The frequency response: that is, the deviation between the measured value and the true value as a function of the frequency. As the ear is capable of hearing sounds between 20 Hz and 20 kHz, the frequency response of the sound level meter should be good, with variations smaller than 1 dB, over that range.
  2. The dynamic range: that is, the range in dB over which the measured value is proportional to the true value, at a given frequency (usually 1000 Hz). This range is limited at low levels by the electrical background noise of the instrument and at high levels by the signal distortion caused by overloading the microphone or amplifiers.
- The electrical signal from the transducer is fed to the pre-amplifier of the sound level meter and, if needed, a weighted filter over a specified range of frequencies.
  - Further amplification prepares the signal either for output to other instruments such as a tape recorder or for rectification and direct reading on the meter.
  - The rectifier gives the RMS value of the signal. The RMS signal is then exponentially averaged using a time constant of 0.1 s ("FAST") or 1 s ("SLOW") and the result is displayed digitally or on an analog meter.
  - In some cases, the sound level meter does not include a logarithmic converter. The scale on the indicating device is then exponential so that the linear signal may be read in dB.

- In this case, the dynamic range of the display is usually restricted to 10 to 16 dB and the precision of the reading is rather poor. In the case of intermittent noise, the user must constantly adjust the amplifier to adapt the output signal to the dynamic range of the display.
- When a log converter is used, the display scale is linear in dB and its dynamic range is usually much greater. This type of display has the advantage of providing the same precision at any level and permitting a much better appreciation of the range of fluctuations of the noise to be measured. In this regard, digital displays are less useful.

**OR**

**Principle**

- The logarithmic term is applied to an electronic voltmeter when the current or voltage produced in the indicating instrument by an applied voltage is proportional to the logarithm of applied voltage.
- Such a characteristics leads to a linear decibel scale for the indicating instruments and finds many applications in electronics.
- The reading on the meter scale is calibrated in decibels and hence the instrument is called a dB voltmeter or simply dB meter.

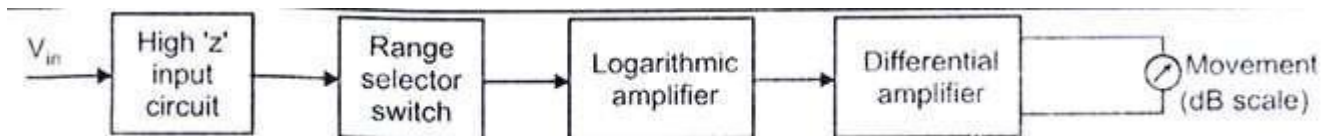

**Figure: Block diagram of dB meter**

**Working:**

- The RF signal to be measured is connected to the input of high impedance input circuit through a RF connector, whose input impedance is 75 Ω. The range selector switch selects the band and range of its frequencies to be tuned.

- The logarithmic amplifier is connected to the differential amplifier whose signal output deflects the dB scale in the dB meter. To obtain logarithmic characteristics, the meter uses a diode in the feedback loop of an op-amp. dB is the unit for losses and gains.

□

c) Draw the block diagram of colour TV transmitter. Describe function of each block. (Diagram:4M explanation:4M)

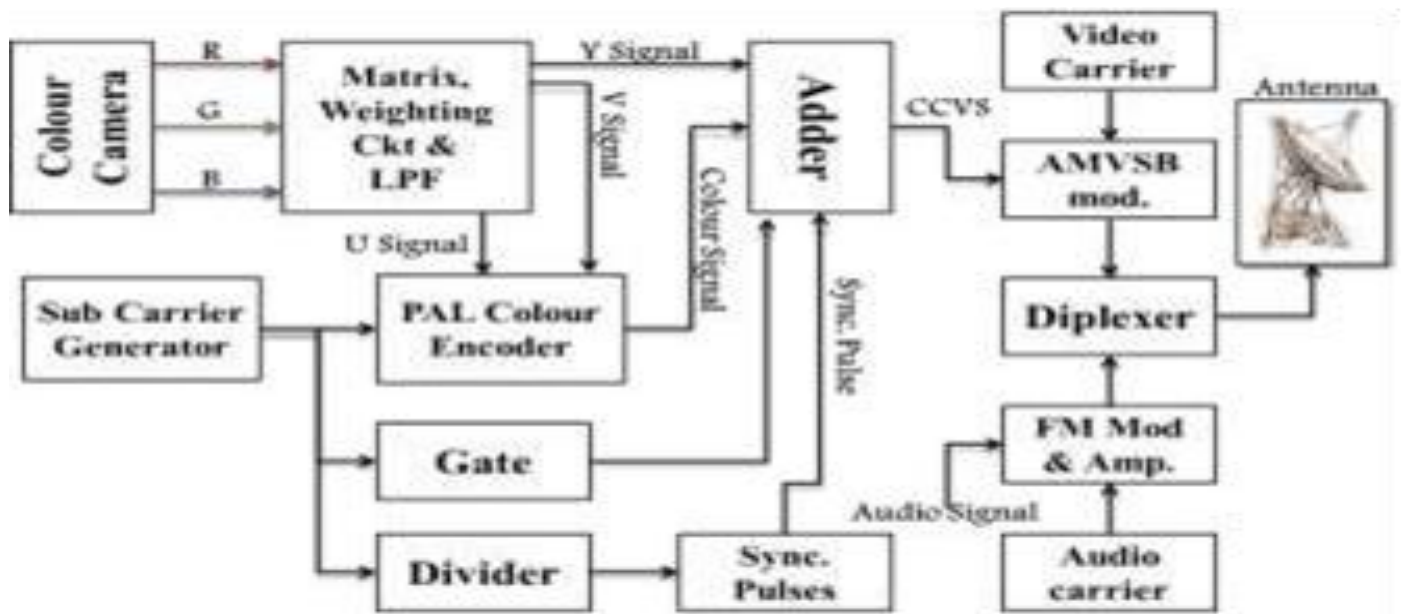

Explanation : 4 marks

A PAL colour TV transmitter consists of following three main sections.

1. Production of Luminance (Y) and Chrominance (U and V) signals
2. PAL encoder
3. Video and Audio modulators and transmitting antenna



**Production of Luminance (Y) and Chrominance (U and V) signals:**

- Colour camera tube produces R, G and B voltages pertaining to the intensity of red, green and blue colours respectively in pixels. The luminance signal Y is obtained by a resistive matrix, using grassman's law.

$$Y=0.3R+0.59G+0.11B.$$

- For colour section Y is inverted colours R&B obtained from the colour camera tubes are added to it to get (R-Y) and (B-Y) colour difference signal. These signals are weighted by two resistive matrix network which gives U & V signals as  $U=0.493 (B-Y)$  &  $V=0.877(R-Y)$

**PAL encoder:**

- PAL switch which operates electronically at 7812.5Hz with the help of bistable multivibrator and feeds the sub-carrier to balanced modulator with phase difference of +90° on one line and -90° on the next line.
- The PAL encoder consists of a **sub carrier generator and two balanced modulator with filters to produce modulated subcarrier signal**. These signals are added vertically to give Chroma signal ©. Then Chroma signal is mixed with Y signal along with sync. And blanking pulses to produce Colour Composite Video Signal (CCVS).

**Video and Audio modulators and transmitting antenna:**

- CCVS amplitude modulates the main video carrier. It is followed by a sharp VSB filter to attenuate the LSB to give AMVSB signal for transmitter. Audio signal modulates separate carrier. This modulation is FM type.
- AMVSB video signal along with audio signal passes to the transmitting antenna through Diplexer Bridge which is a wheat-stone's bridge.

Q6) Attempt any four:

16

a) State and explain primary colour and secondary colour Grassman's law for colour theory. (4M)

- The eye is not able to distinguish each colour that are mixed from colours but instead perceives only resultant colour.
- For example, Yellow can be produced by mixing 30% of red and 59% of green.
- Eye perceives yellow colour depending on the algebraic sum of red, green and blue light fluxes. This forms the basis of color signal generation and is known as Grassman's Law.
- White has been seen to be produced by adding red, green and blue lights
- The intensity of each color may be varied.
- This enables simple rule of addition and subtraction.

b) Draw delta gun picture tube. (4M)

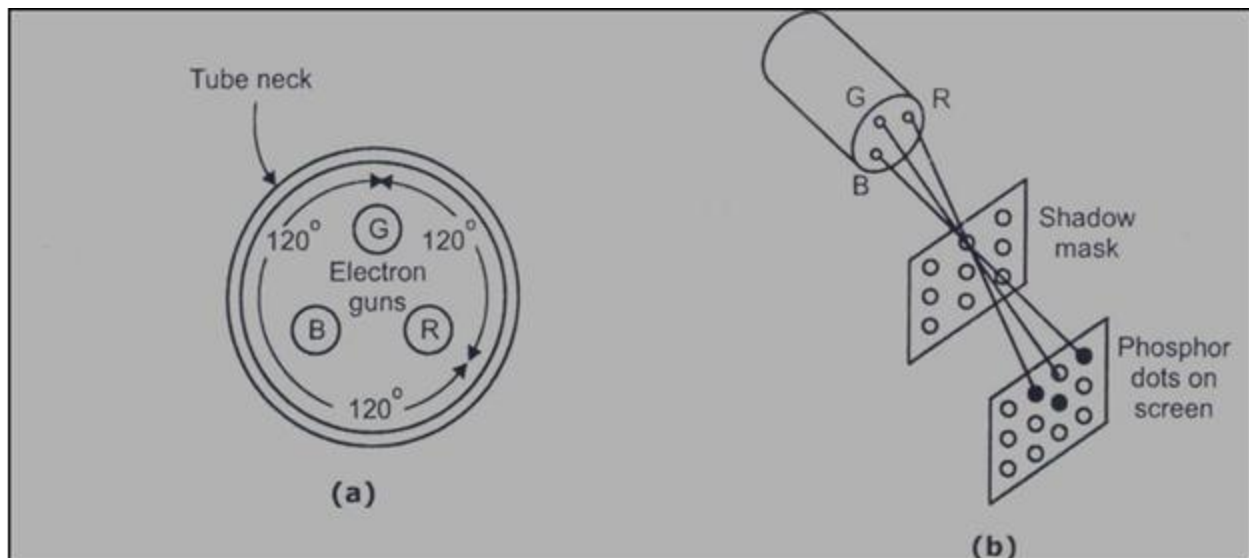

c) Compare MATV, CATV and CCTV (any 8 points). (1 M each point)



CATV	CCTV	MATV
CATV stands for Cable Television	CCTV stands for Closed Circuit Television	MATV stands for Master Antenna Television
Used in large complexes for broadcast purposes	Used for surveillance and distance education, Military installation	Used in firing areas where signal is weak
Local studio signals can be added	Visible to limited number of viewers	All signals are added in hybrid network and fed to subscriber
Distribution system can provide connections and facility to a large number of subscribers	Picture is not broadcaste	Subscribers are limited ,if subscriber increase number of antenna has to increase
Two way cable system can be provided	Live or prerecorded signal are sent over a closed loop to finite number of recievers	Two way cable system are not used .weak signal cannot be received so antenna is installed at the top and signal is processed through head end and distribution network and fed to subscriber.
Audio section is present	Audio section is not present.	Audio section is not present.

Internet services can be provided	Internet service cannot be provided.	Internet service cannot be provided.
Complex circuitry.	Simple circuitry.	Complex circuitry.

d) Describe public addressing system and mono amplifier. (Diagram: 1M each  
explanation: 1M each)

Mono amplifier:

In mono amplifier only one amplifier is used and it gives one direction sound.

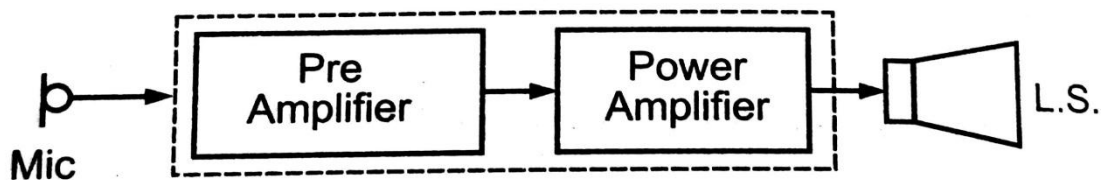

Mic: It converts original information into electrical signal which is fed as input to first stage.

Pre amplifier :Voltage amplifier is used as pre amplifier or first stage, The main function of voltage amplifier is to amplify audio signal voltage to drive power amplifier.

Power amplifier: It is last stage which feeds amplifier audio power to drive loud speaker.

Loud speaker: It converts electrical signal into original sound.

Public addressing system:

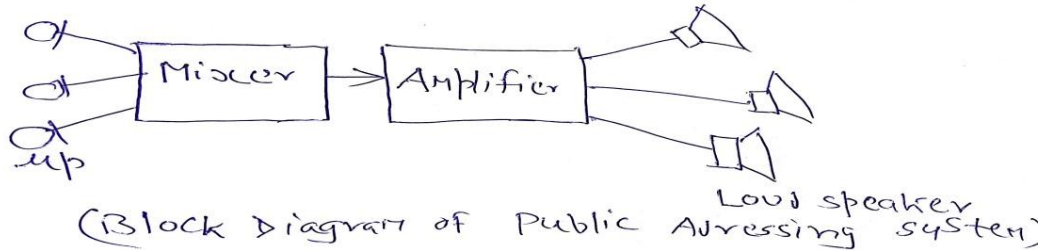

OR

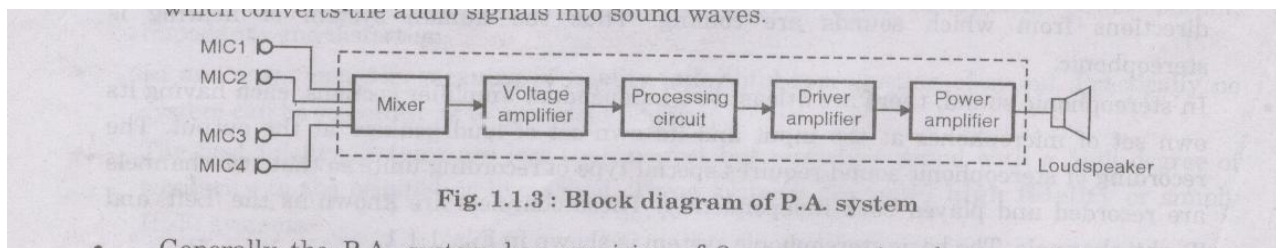

PA amplifier is electro-acoustic system, in which amplifier sound provides comfortable listening to large gathering as in public meeting, sports or to isolated location as at railway stations air ports etc.

The PA system consists of microphones, mixers, voltage amplifiers, processing circuits and power amplifier. It is an electro acoustical system in which sound is first converted into electrical signals by microphones. The electrical audio signals are amplified, processed and fed to the loudspeaker which converts the audio signal into sound wave.

e) Describe the importance of Pre and post equalizing pulses: (explanation: 2M each)





To take care of drawback which occur on account of the half line discrepancy, five narrow pulse are added on either side of vertical sync pulses. These are known as pre equalizing and post equalizing pulses.

Pre-equalizing Pulse : they are of 2.5micro second duration results in discharge of capacitor to essentially zero voltage in both the fields despite half line discrepancy before the voltage built-up starts with the arrival of vertical sync pulses.

Post equalizing pulse :It is necessary for fast discharge of capacitor to ensure triggering of vertical oscillator at proper time .