



**Important Instructions to examiners:**

- 1) The answers should be examined by key words and not as word-to-word as given in the model answer scheme.
- 2) The model answer and the answer written by candidate may vary but the examiner may try to assess the understanding level of the candidate.
- 3) The language errors such as grammatical, spelling errors should not be given more Importance (Not applicable for subject English and Communication Skills).
- 4) While assessing figures, examiner may give credit for principal components indicated in the figure. The figures drawn by candidate and model answer may vary. The examiner may give credit for any equivalent figure drawn.
- 5) Credits may be given step wise for numerical problems. In some cases, the assumed constant values may vary and there may be some difference in the candidate's answers and model answer.
- 6) In case of some questions credit may be given by judgement on part of examiner of relevant answer based on candidate's understanding.
- 7) For programming language papers, credit may be given to any other program based on equivalent concept.

**Q. 1. A. Attempt any Three**

**(12)**

**a. Characteristics of cutting tool materials (any four characteristics)**

**(4M)**

1. Hot/Red hardness, necessary to enable the cutting tool to retain its cutting ability and hardness at the high temperatures developed at the tool-chip interface
2. Wear resistance, necessary to enable the cutting tool to retain its shape and cutting efficiency
3. Toughness, necessary to enable the tool to withstand the forces, to absorb shocks associated with interrupted cuts and to prevent the chipping of the fine cutting edge
4. Mechanical and thermal shock resistance
5. Ability to maintain the above properties at the temperatures occurring during cutting
6. Low friction, in order to have low tool wear and better surface finish, the coeff. of friction between the chip and tool should be as low as possible in the operating range of speed and feed
7. Favorable cost of material
8. Should be easy to regrind and easily weld-able to tool

**b. Geometry of single point cutting tool** (any one of below fig.)

(4M)

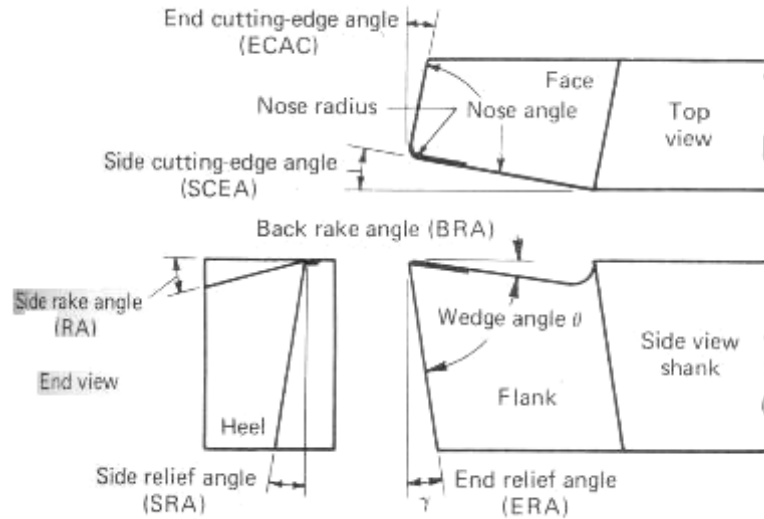

**c. Specification of OBI press**

(2M)

Capacity- 4-10 ton

Stroke- 1"

Shut height- 5-7 /2"

Clutch type- Mechanical

Opening through back- 5 1/4"

Voltage- 220V, 3 Phase

Horsepower- 2 to 4 HP

**Function of flywheel**

(2M)

The heavy flywheel absorbs energy continuously from an electric motor and delivers it to the ram and hence to the work piece intermittently.

**d. Spring back-**

(4M)

At the end of bending operation, when the pressure on the metal is released there is an elastic recovery by the material. This causes a decrease in the bend angle and this phenomenon is called as spring back.

To overcome the spring back the wedge shaped punches and the mating dies are made with an included angles somewhat less than required in the formed component. Due to this component will be bent to a greater angle than desired, but it will spring back to desired angle.



**Q. 1. B. Attempt any One**

**(08)**

**a. Comparison between orthogonal cutting and oblique cutting (any four points) (8M)**

Sr. No.	Orthogonal Cutting	Oblique Cutting
1	Cutting edge of the tool is perpendicular to the direction of travel of the tool	Cutting edge is inclined at an angle with the normal to the direction of tool travel
2	Cutting edge clears the width of the w/p on either ends	Cutting edge may or may not clear the width of the w/p
3	The chip coils are tight and flat spiral	The chip flows sideways in a long curl
4	Only two components of the forces are acting on the tool	Three components of the forces acting
5	Maximum chip thickness occurs at the middle	Maximum chip thickness may not occur at middle
6	Due to smaller area of the tool, less friction in between work-tool interface therefore tool life is more	It acts on larger area and thus tool life is less

**b. Comparison between compound die and combination die (any four points) (8M)**

**(8M)**

Sr. No.	Compound Die	Combination Die
1	Two or more operations performed at a one station	More than one operation performed at a one station
2	Such dies are considered as cutting tools since, only cutting operations are carried out.	A cutting operation is combined with a bending or drawing operation.



3	Piercing punch is used	Drawing punch is used
4	Blanking and piercing operations	Blanking, piercing, trimming and cut off are combined with non cutting operations
5	More accurate and economical in mass production	Less accurate than compound die
6	Large parts can be blanked by compound dies	Large parts cannot be blanked by combination dies

**Q. 2. Attempt any Four**

**(16)**

**a. Define**

**(2m each)**

**1. Chip thickness ratio (r)** - It is the ratio of uncut or unreformed chip thickness (t) to the chip thickness after the metal is cut ( $t_c$ ).

$$r = \frac{t}{t_c}$$

**2. Shear angle-** It is defined as the angle made by the shear plane, with the direction of the tool travel.

**b. Tool life-** The total cutting time accumulated before tool failure occurs is termed as 'tool life'. **(1m)**

**Tool life equation- (1m)**

$$VT^n = C$$

Where V= cutting speed (m.min) and T = time in mins.

**Factors on which tool life depended-**

**(2m)**

- I. Depth of cut (d)
- II. Feed rate (f)
- III. Cutting speed (v)
- IV. Type of coolant



**c. Strip layout-**

**(2m)**

In the design of blanking die set, the first step is to prepare blanking layout i.e. to layout the position of the workpieces in the strip and their orientation with respect to one another. This called strip layout.

**Factors which influences the stock layout- (any four)**

**(2m)**

1. Economy of material
2. Direction of material grain or fibre
3. Strip or coiled stock
4. Direction of burr
5. Press used
6. Production required
7. Die cost

**d.** During drawing process metal flows with tensile forces with stretching effect. As the metal is **drawn** (pulled), it stretches thinner, into a desired shape and thickness. **(2m)**

**Following variables affected metal flow during drawing –**

**(2m)**

1. **Radius on punch:** A general rule to prevent excessive thinning is to design the punch with a radius of from 4 to 10 times the metal thickness. Otherwise a sharp radius will require higher forces when the metal is folded around the punch nose & may result in excessive thinning on tearing at the bottom of the cup.
2. **Draw radius on die:** Theoretically the radius on the draw die should be as large as possible to permit full freedom of metal flow as it passes over the radius. If the draw radius is too large, the metal will be released by the blank holder too soon & wrinkling will result. Too sharp a radius will hinder the normal flow of metal & cause uneven thinning.
3. **Friction:** The force of static friction between the work piece blank & draw die surface must be overcome in a drawing operation. Since the blank holder pressure causes higher frictional forces, it should be only high enough to prevent wrinkling of the metal. A smooth surface on the work material & the mating die surface will result in less friction.
4. **Material to be drawn:** The characteristics of the material to be drawn have a great influence on the success of a drawing operation. Ductility & yield strength are the most important. A low yield strength is desirable so that metal flow can begin without leaving near the punch radius.

**e. Metal extrusion dies**

**(4m)**

Metal extrusion die, used in manufacturing extruded sections, must have certain mechanical characteristics. Extrusion die must be strong and hard, capable of holding their dimensional accuracy



throughout the high stresses created during the manufacturing process. They must also be resistant to wear, which is always an issue when extruding metal in large quantities. Dies for hot extrusion must have high thermal resistance and be able to maintain strength and hardness at elevated temperatures. Tool steels are a common type of material for metal extrusion molds. Extruding dies may be coated to increase wear resistance. Carbides are sometimes used for a mold material, carbides do not wear easy and can provide accurate part dimensions.

**Q. 3. Attempt any Two**

**(16)**

**a. Types of chips-**

**(2m)**

1. Segmental or discontinuous chip
2. Continuous chip
3. Continuous chip with built up edge
4. Non-homogeneous chip

**Conditions in which above chips are generated –**

**(4m)**

Sr. No.	Types of chips	Conditions
1	Segmental or discontinuous chip	Produced in brittle material machining and while cutting ductile material at low speed with high DOC
2	Continuous chip	Produced ductile material machining at normal cutting speeds with lower DOC
3	Continuous chip with built up edge	Cutting ductile materials with high speed steel tools at low cutting speeds
4	Non-homogeneous chip	Due to the higher temperature at shear plane a large strain is developed at the tool chip interface at medium cutting speeds

**Benefits of Continuous chip- (2m)**

After generation of continuous chips during machining the quality of machined surface is quiet better (low surface roughness value) than discontinuous chips generation.

**b. Material utilization factor-****(2m)**

A term used to describe the difference between the raw material weight used to produce a part and the actual weight of the finished part. The higher the percentage of utilization, the better and more economical the stamping process.

**Definitions****(1.5 m each) (6m)**

1. Blanking- It is the operation of cutting a flat shape from sheet metal. The article punched out is called the blank and is the required product of operation.
2. Piercing- It is a cutting operation by which various shaped holes are made in sheet metal.
3. Shearing- Cutting the sheet into two or more pieces.
4. Drawing- This is a process of forming a flat workpiece into a hollow shape by means of punch which causes the blank to flow into a die cavity.

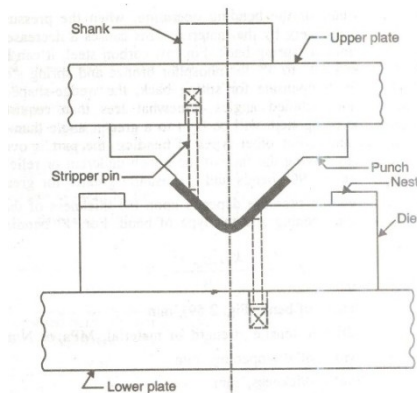
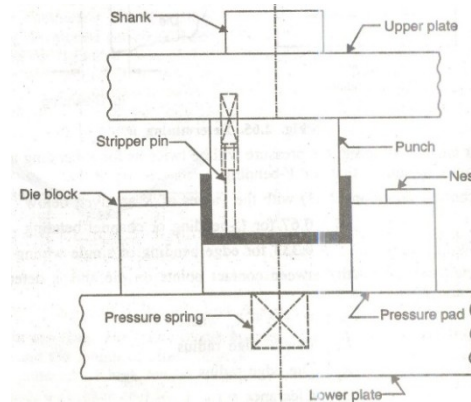
**c. Bending dies****(8m)****1. V Bending Die and U bending Die****(2m each) 4m****(a) V-Bending Die****(b) U-Bending Die**

In U or channel bending, the pressure will be twice as for V bending and for edge bending it will be about one-half of that V bending. One of the most common types of sheet metal manufacturing processes is V bending. The V shaped punch forces the work into the V shaped die and hence bends it. This type of process can bend both very acute and very obtuse angles, also anything in between, including 90degrees.

For channel or U bending where bottoming force is necessary, a blank holding pad is generally employed. To calculate the press capacity the resistance of the pressure pad should be added to the required bending force. Channel bending uses a shaped punch and die to form a sheet metal channel. A U bend is made with a U shaped punch of the correct curvature.

**b. Bend allowance- (2m fig. and 2m explanation)**

**(4m)**

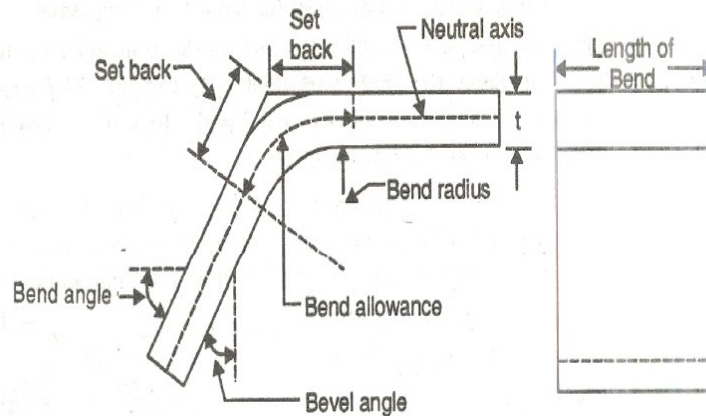

To calculate the blank length for bending, the length of material in the curved section has to be calculated. This length in the bend area which will be more than the corresponding length of blank before bending is called 'Bend Allowance'. It can be calculated by following formulae

$$B = \frac{\alpha}{360} + 2\pi (r + k)$$

Where, B= Bend allowance along neutral axis

A = Bend angle in degrees

r = inside radius of bend in cm

k = Distance of neutral axis from the inside surface of the bend in cm

**Q. 4. Attempt any FOUR**

**a) What are different tool materials? State its applications**

Ans :- Tool Materials are as follows - **(3 m)**

1.Tool Steels 2.High Speed Steels 3. Cemented carbides 4. Ceramics 5. Diamonds 6. Cast iron

Applications:- **(1 m)**

1.Pneumatic Chisels, Punches, broaches, knurling tools, dies, forming tools etc

2.Jigs and Fixtures, Steel Mill etc

3.Cutting edges, inserts, etc

4.To clamp the tip to the shank etc

5.Light cuts and finishing operation, truing the grinding wheels, etc

6.Large forming and drawing dies, die set shoes, etc

**b) What are different types of cutting fluid? State its applications**

Ans :- Types of cutting fluid- **(3 m)**

1. Water based cutting fluids



2. Straight or neat oil based cutting fluids

- a) Mineral oils
- b) Straight fatty oils
- c) Compounded or blended oils
- d) Sulphurised oils
- e) Chlorinated oils

**Applications:-** Heavy duty such as threading on capstan and turret lathes, thread milling, medium capacity automatic lathes, thread cutting with taps and dies ,gear cutting etc **(1m)**

**c) State the function of i) Pilots ii) Strippers iii) Feed stop iv) Stock guide (1 m each)**

Ans:- i) Pilots:- The function is to position the work piece or stock strip accurately. When establishing the sequence of operations for progressive dies, piercing operations are carried out first.

ii) Strippers: - The function is to remove the stock from the punch after blanking or piercing operation.

iii) Feed stop: - The function is the strip of sheet metal is fed and guided through a slot in the stock guide or through a slot in the stripper plate.

iv) Stock guide: - The function is the space provided in the die-block, through which the stock strip is guided as it is fed into the die.

**d) Draw a neat sketch of blanking and label it. State the factors on which bending pressure depends.**

Ans:- **Fig-2 mark Factors- 2 Mark**

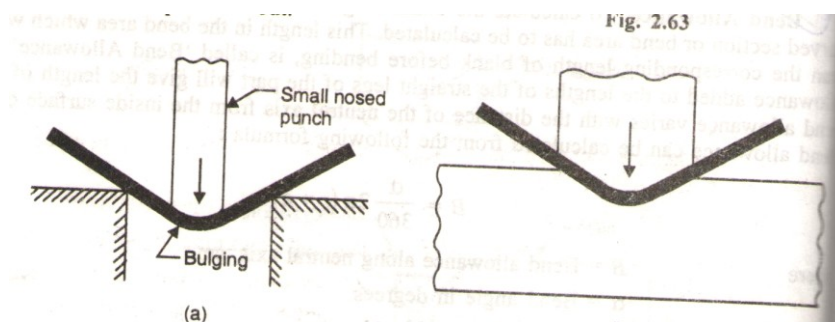

**Bending pressure** depends upon the thickness of the stock, the length of the bend, the width of die opening and the type of bend.

**e) Explain the constructional features of forging dies**

Ans :-

Forging is the operation where the metal is heated and then a force is applied to manipulate the metal in such a way that the required final shape is obtained

The features are as follows

1/2 Mark each

1. To calculate blank size by considering various losses
2. Draft angles to facilitate the removal of forgings from the die the draft angle is provided.
3. Fillet and corner radii are rounding of the apex of an internal angle whereas apex of an external angle. These are necessary to avoid the formation of forging defects and to prolong die life.
4. Minimum section size is to avoid excess metal on large webs to reduce weight of forging.
5. Parting lines separates the top and bottom dies .
6. Die mismatch is the misalignment of top and bottom dies.
7. Forging tolerance and allowances is an additional amount of metal added to the surfaces which can not be controlled close enough by forging and be machined.
8. Flash and gutter size. Flash is that portion of excess metal which is adjoining the forging at the parting line. In addition to the flash extension a further provision must be made in the die for any excess material

**Q.5. Attempt any Four**

**a) Explain Merchant circle**

Ans :- Merchant is able to build up a picture of forces acting in the region of cutting which give rise to plastic deformation and sliding of the chip down the tool rake face.

(Fig-2 Mark Explanation-2 Mark)

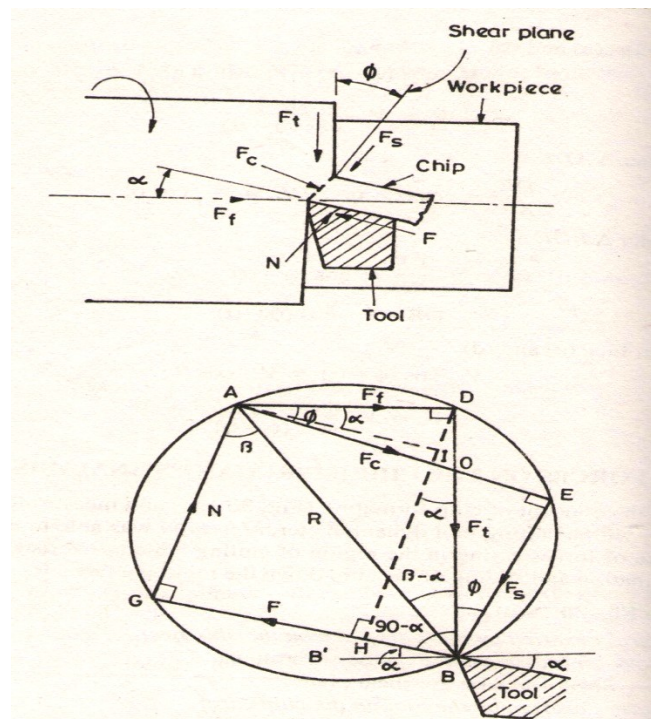



The forces exerted by the work piece on the chip are-

F<sub>c</sub>-compressive force on the shear plane

F<sub>s</sub>-shear force on the shear plane

The forces exerted by the tool on the chips are

N-normal force at the rake face of tool

F-Frictional force along the rake face of tool.

The forces acting on the tool and measured by dynamometer are-

F<sub>t</sub>- tangential or cutting force

F<sub>f</sub>-feed force

Angle  $\alpha$  is tool rake angle,

$\Phi$  is shear plane angle and

$\beta$  is the angle of friction

By using graphical method it is possible to find the force F<sub>c</sub>, F<sub>s</sub>, N and F.

Draw F<sub>f</sub> and F<sub>t</sub> to some convenient scale and join AB to obtain their resultant. Bisect AB and draw a circle having the resultant force as its diameter. Set off BE, making angle  $\Phi$  with force F<sub>t</sub>, to cut circle at E. Join EA. The magnitudes of F<sub>s</sub> and F<sub>c</sub> are now known. Set off a line BG, at an angle  $(90-\alpha)$  with F<sub>t</sub>. Join GA. The magnitude of forces N and F are thus known, as also the coefficient of friction at the chip-tool interface(F/N). Angle BAG is the angle of friction between chip and tool.

$$\tan\beta = F/N$$

**b) Explain heat treatment process of tool steels.**

**Explanation – 4 Marks**

Ans:- Heat treating of steel is the process of heating and cooling of carbon steel to change the steel's physical and mechanical properties without changing the original shape and size.

Heat Treating is often associated with increasing the strength of the steel, but it can also be used to alter certain manufacturability objectives such as improve machinability, formability, restore ductility etc. Thus heat treating is a very useful process to helps other manufacturing processes and also improve product performance by increasing strength or provides other desirable characteristics. High carbon steels are particularly suitable for heat treatment, since carbon steel respond well to heat treatment and the commercial use of steels exceeds that of any other material.

There are many difference types of heat treating processes, it individual process provides different desirable characteristics to the product.

Annealing : Slow & uniform heating in the range of 790- 800°C followed by furnace cooling at rate of 8-15°C/hr. Stress relieving : Heat to 650- 675°C and furnace cooling. Hardening : Preheating – warming to about 650°C & holding for 20 minutes/ 25mm. Austenitizing – heating to 900-950°C &



holding again for 20minutes/25mm. Tempering : Heating to 205-650°C, holding for 30 minutes/25mm and then, air cooling.

**c) What is meant by clearance? Why is it important in shearing operation? 2 m Each**

Ans:- Clearance is the intentional space between the punch cutting edge and the die cutting edge. It is expressed as the amount of clearance per side. Clearance is necessary to allow the fractures to meet when break occurs.

It is important in shearing because the diameter of the blank or punched hole is determined by the burnished area. On the blank, the burnished area is produced by the walls of the die. Therefore, the blank size will be equal to the size of die-opening. Similarly, in punching operation, the burnished area in the hole is produced by the punch; therefore the size of the hole will be the same as the punch. Therefore, the application of clearance on punch or die will depend on whether the punched hole or the cut blank is the desired product. Hence, in punching operation, the punch is made to the correct hole size and the die opening is made oversize an amount equal to die clearance. Similarly, if the blank is the desired product, the die opening size is made to the correct blank size and the punch is made smaller an amount equal to die clearance, In other words, punch controls the hole size and die opening controls the blank size.

**d) Calculate the bending force for channel bending using following data:**

Thickness of blank = 3.2 mm

Bending length = 900 mm

Die radius = Punch radius = 9.5 mm

Ultimate tensile strength of materials = 400 N/ mm<sup>2</sup>.

Use k = 0.67 for channel bending.

Ans :- We know Bending Force =  $F = k.l.\sigma_u.t^2/W$

$$W = R_1 + R_2 + C = 9.5 + 9.5 + 3.2 = 22.2 \text{ mm}$$

$$F = 0.67 \times 900 \times 400 \times 3.2 \times 3.2 / 22.2$$

$$= 111.25 \text{ KN} \text{ -----}$$

**(2+2Marks)**

**e) Explain pressure die casting dies. ( Expl. Any one type -2 Mark with fig 2 Marks)**

Ans:- Pressure die casting is a quick, reliable and cost-effective manufacturing process for production of high volume, metal components that are net-shaped have tight tolerances. Basically, the pressure die casting process consists of injecting under high pressure a molten metal alloy into a steel mold (or tool). This gets solidified rapidly (from milliseconds to a few seconds) to form a net shaped component. It is then automatically extracted.

Depending upon the pressure used, there are two types of pressure die casting namely High Pressure Die Casting and Low Pressure Die Casting. While high pressure die casting has wider application encompassing nearly 50% of all light alloy casting production. Currently low pressure die casting accounts for about 20% of the total production but its use is increasing. High pressure castings are must for castings requiring tight tolerance and detailed geometry. As the extra pressure is able to push the metal into more detailed features in the mold. Low pressure die casting is commonly used for larger and non-critical parts.

However, the machine and its dies are very costly, and for this reason pressure die casting is viable only for high-volume production.

### High Pressure Die Casting

Here, the liquid metal is injected with high speed and high pressure into the metal mold. The basic equipment consists of two vertical platens. The bolsters are placed on these platens and this holds the die halves. Out of the two platens, one is fixed and the other movable.

#### High Pressure Die Casting Process

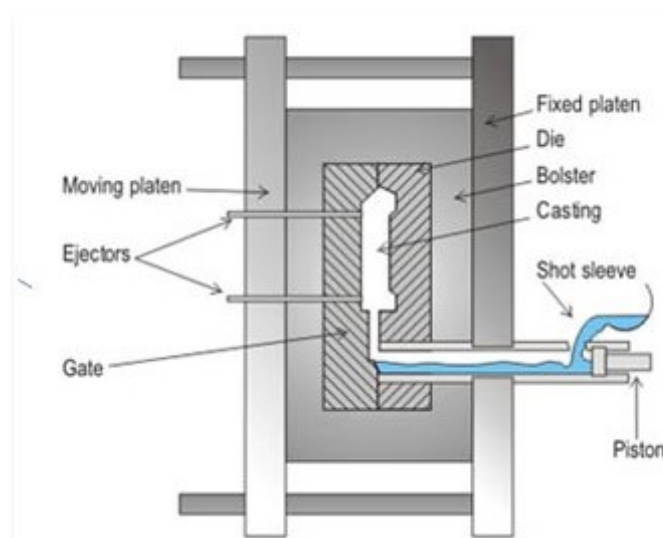

This helps the die to open and close. A specific amount of metal is poured into the shot sleeve and afterwards introduced into the mold cavity. This is done using a hydraulically-driven piston. After the metal has solidified, the die is opened and the casting eventually removed.

### Low Pressure Die Casting

High quality castings, of aluminium alloys, along with magnesium and other low melting point alloys are usually produced through this process. Castings of aluminium in the weight range of 2-150 kg are a common feature.

The process works like this, first a metal die is positioned above a sealed furnace containing molten metal. A refractory-lined riser extends from the bottom of the die into the molten metal. Low pressure air (15 - 100 kPa, 2- 15 psi) is then introduced into the furnace. This makes the molten metal rise up the tube and enters the die cavity with low turbulence. After the metal has solidified, the air pressure is released. This makes the metal still in the molten state in the riser tube to fall back into the furnace. After subsequent cooling, the die is opened and the casting extracted.

With correct die design it is possible to eliminate the need of the riser also. This is because of the directional freezing of the casting. After the sequence has been established, the process can be controlled automatically using temperature and pressure controllers to oversee the operation of more than one die-casting machine.

Casting yield is exceptionally high as there is usually only one ingate and no feeders.

### Low Pressure Die Casting Process

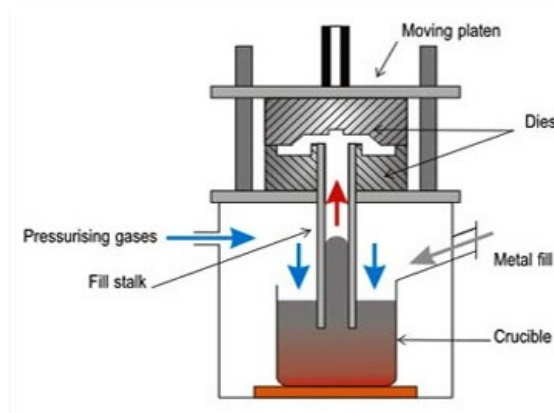

### 6. Attempt any Two

a) What are the different types of ceramic coatings? Write the specification of carbide tips.

Why heat treatment is given to tool steels?

Ans:- Type of ceramic coatings

( 4 +2 +2=8m)

Some of the most popular plasma sprayed ceramic coatings include:

1. Alumina-Titania based ceramics for wear, corrosion and variable texture surfacing.
2. Chrome-oxide ceramic coatings are extremely durable, ideal for seal surfaces.
3. Zirconia based ceramic are un-matched as thermal barrier and heat-shield coatings.

The heat treatment includes heating and cooling operations or the sequence of two or more such operations applied to any material in order to modify its metallurgical structure and alter its physical, mechanical and chemical properties. Usually it consists of heating the material to some specific temperature, holding at this temperature for a definite period and cooling to room temperature or

below with a definite rate. Annealing, Normalizing, Hardening and Tempering are the four widely used heat treatment processes that affect the structure and properties, and are assigned to meet the specific requirements from the semi-fabricated and finished components. Steels being the most widely used materials in major engineering fabrications undergo various heat treatment cycles depending on the requirements. Also aluminum and nickel alloys are exposed to heat treatment for enhancement of properties

**b) State the factors on which bending pressure depends? How the size of a blank is calculated for drawing a cup?**

Ans:-

**(2 Marks Explanation :-6 Marks)**

Bending pressure depends upon the thickness of the stock, the length of the bend, the width of die opening and the type of bend.

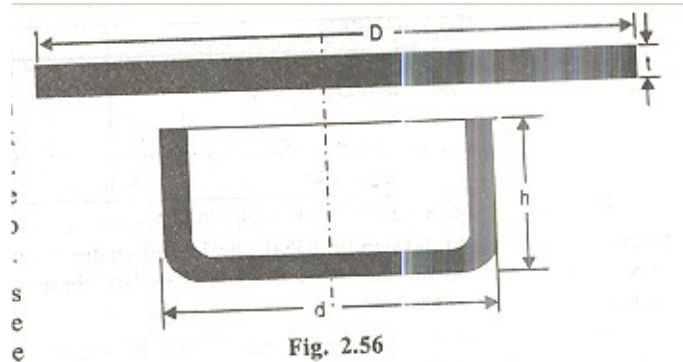

The first step in the drawing process is to calculate the approximate size of the blank required for a particular drawn part. There are several methods to do so, but below we give the equations based on area methods to determine the blank size for drawing plain cylindrical shells. In this method it is assumed that the surface area of the blank is equal to the surface area of the finished shell.

- 1) Where thin gauge stock is used and the shell has sharp inside corners the formula may be used

$$D = \sqrt{d^2 + 4dh}$$

Where D is the diameter of the flat blank, d is the diameter of finished shell and h is the height of finished shell. This formula is valid for  $d/r \geq 20$  and more, where r is the radius of bottom corner.

- 2) For a round corner cup when the ratio  $d/r$  is between 15 and 20 the formula becomes

$$D = \sqrt{d^2 + 4dh} - 0.5r$$

- 3)  $D = \sqrt{d^2 + 4dh} - r$ , where  $d/r$  is between 10 and 15.

- 4) When  $d/r < 10$

$$D = \sqrt{(d-2r)^2 + 4d(h-r)} + 2\pi r (d-0.7r)$$

- 5) If thick gauge stock is used, use net or mean diameter for  $d$  in the above formulas
- 6) On flanged cylindrical shells with relatively sharp corners, use the following formula  
 $D = \sqrt{d_2^2 + 4d_1h}$  where  $d_2$  is the outer diameter of flange on finished shell and  $d_1$  is the diameter of cylindrical section on finished shell.
- 7) When deep drawing is done along with ironing so that the thickness of the wall of the shell is less than that of the bottom of the shell, the blank size can be approximately determined as

$$D = \sqrt{d^2 + 4dh} \cdot t/T \quad \text{where } t = \text{wall thickness and } T = \text{bottom thickness}$$

**c) (i) Explain bending terminology with the help of a suitable sketch. (Explanation-2, Sketch-2)**

Ans :- Bending is the metal working process by which a straight length is transformed into a curved length. It is a very common forming process for changing sheet and plate into channels, drums, tanks etc. During the bending operation, the outer surface of the material is in tension and the inside surface is in compression. The strain in the bent material increases with decreasing radius of curvature. The stretching of the bending causes the neutral axis of the section to move towards the inner surface. In most cases, the distance of the neutral axis from the inside of the bend is  $0.3t$  to  $0.5t$ , where  $t$  is the thickness of the part. Bending terminology as shown below.

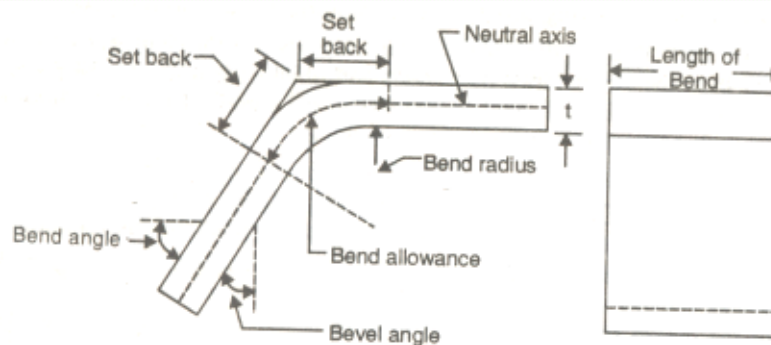

**(ii) State the two products each manufactured by using**

**(1) Metal extrusion dies**

**(2) Forging dies**

Ans:-

**(Any Two products - 2 marks each)**

1. Bars, hollow tubes, tooth paste tubes, pipes of complex configuration etc
2. Hubs, small bevel gears, Gear blank, lever, connecting rod etc

-----XXXXXX-----