



**Important Instructions to examiners:**

- 1) The answers should be examined by keywords and not as word-to-word as given in the model answer scheme.
- 2) The model answer and the answer written by candidate may vary but the examiner may try to assess the understanding level of the candidate.
- 3) The language errors such as grammatical, spelling errors should not be given more Importance. (Not applicable for subject English and Communication Skills.)
- 4) While assessing figures, examiner may give credit for principal components indicated in the figure. The figures drawn by candidate and model answer may vary. The examiner may give credit for any equivalent figure drawn.
- 5) Credits may be given step wise for numerical problems. In some cases, the assumed constant values may vary and there may be some difference in the candidate's answers and model answer.
- 6) In case of some questions credit may be given by judgement on part of examiner of relevant answer based on candidate's understanding.
- 7) For programming language papers, credit may be given to any other program based on equivalent concept.

Q. No.	Question & its Answer	Remark	Total Marks																																								
01A)	<b>Attempt Any THREE</b>		<b>12</b>																																								
a)	<b>Consider a system with characteristics equation <math>S^5 + 2S^4 + 2S^3 + 4S^2 + 11S + 10 = 0</math>. Determine stability using Routh's Criteria.</b>		<b>04</b>																																								
Ans	<p>1) Firstly Find even &amp; odd coefficient from characteristics equation  <math>S^5 + 2.S^4 + 2.S^3 + 4.S^2 + 11.S + 10 = 0</math>.</p> <p>2) The routh's array for above characteristics equation is formed as follows</p> <table style="margin-left: 40px;"> <tr><td style="border-top: 1px solid black;"><math>S^5</math></td><td>1</td><td>2</td><td>11</td><td></td></tr> <tr><td><math>S^4</math></td><td>2</td><td>4</td><td>10</td><td></td></tr> <tr><td><math>S^3</math></td><td>0</td><td>6</td><td>0</td><td>special case</td></tr> <tr><td><math>S^2</math></td><td><math>\infty</math></td><td>10</td><td></td><td></td></tr> <tr><td><math>S^1</math></td><td></td><td></td><td></td><td></td></tr> <tr><td><math>S^0</math></td><td></td><td></td><td></td><td></td></tr> </table> <p>Substitute a small positive number <math>\epsilon</math> in place of 0 occurred as a first element in a row. Complete the array with this number <math>\epsilon</math>. Then examine the sign change by taking <math>\lim_{\epsilon \rightarrow 0}</math></p> <table style="margin-left: 40px;"> <tr><td style="border-top: 1px solid black;"><math>S^5</math></td><td>1</td><td>2</td><td>11</td><td></td></tr> <tr><td><math>S^4</math></td><td>2</td><td>4</td><td>10</td><td></td></tr> </table>	$S^5$	1	2	11		$S^4$	2	4	10		$S^3$	0	6	0	special case	$S^2$	$\infty$	10			$S^1$					$S^0$					$S^5$	1	2	11		$S^4$	2	4	10		1mark	
$S^5$	1	2	11																																								
$S^4$	2	4	10																																								
$S^3$	0	6	0	special case																																							
$S^2$	$\infty$	10																																									
$S^1$																																											
$S^0$																																											
$S^5$	1	2	11																																								
$S^4$	2	4	10																																								
		1 Mark																																									



	$S^3 \quad \epsilon \quad 6 \quad 0$ $S^2 \quad 4\epsilon - 12 / \epsilon \quad 10 \quad 0$ $S^1 \quad \frac{(24\epsilon - 72 - 10\epsilon^2)}{4\epsilon - 12} \quad 0 \quad 0$ $S^0 \quad 10 \quad 0 \quad 0$ <p>To examine sign change</p> $\lim_{\epsilon \rightarrow 0} 4\epsilon - 12 / \epsilon = \infty$ $\lim_{\epsilon \rightarrow 0} (24\epsilon - 72 - 10\epsilon^2) / 4\epsilon - 12 = 6$ <p>So, Final Array is</p> <hr/> <table style="width: 100%; border-collapse: collapse;"> <tr> <td style="width: 15%;"><math>S^5</math></td> <td style="width: 15%;">1</td> <td style="width: 15%;">2</td> <td style="width: 15%;">11</td> </tr> <tr> <td><math>S^4</math></td> <td>2</td> <td>4</td> <td>10</td> </tr> <tr> <td><math>S^3</math></td> <td><math>\epsilon</math></td> <td>6</td> <td>0</td> </tr> <tr> <td><math>S^2</math></td> <td><math>\infty</math></td> <td>10</td> <td>0</td> </tr> <tr> <td><math>S^1</math></td> <td>6</td> <td>0</td> <td>0</td> </tr> <tr> <td><math>S^0</math></td> <td>10</td> <td>0</td> <td>0</td> </tr> </table> <p>Routh's stability criteria states that the elements of 1st column of Routh's array should not have any sign change for the system to be stable. The number of sign changes in the 1st column indicates the number of Poles on RHS which makes the system unstable. Here, No sign changes in the 1st column indicate system is stable. (Note:- Alternative method of Rouths Array by replacing S with 1/Z in the original equation also can be considered n .)</p>	$S^5$	1	2	11	$S^4$	2	4	10	$S^3$	$\epsilon$	6	0	$S^2$	$\infty$	10	0	$S^1$	6	0	0	$S^0$	10	0	0	1Mark	
$S^5$	1	2	11																								
$S^4$	2	4	10																								
$S^3$	$\epsilon$	6	0																								
$S^2$	$\infty$	10	0																								
$S^1$	6	0	0																								
$S^0$	10	0	0																								
<b>b)</b>	<b>List any four advantages of PLC</b>		<b>04</b>																								
<b>Ans</b>	<ul style="list-style-type: none"> <li>• Reduce human efforts</li> <li>• Maximum efficiency through machine and logic is controlled by human</li> <li>• Higher productivity</li> <li>• Superior quality of end products</li> <li>• Efficient uses of energy and raw material</li> <li>• Eliminate the high costs associated with inflexible, relay-controlled systems</li> </ul>	<b>1 mark each point</b>																									



	<ul style="list-style-type: none"> <li>Improved safety in working conditions.</li> <li>Easily programmed and have an easily understood programming language.</li> </ul>																																									
<b>c)</b>	<b>Compare open loop and closed loop control system(four points)</b>		<b>04</b>																																							
<b>Ans</b>	<table border="1"> <thead> <tr> <th>No.</th> <th>Open Loop Control System</th> <th>Close Loop Control System</th> </tr> </thead> <tbody> <tr> <td>1</td> <td>It is simple and economical</td> <td>It is complex and costlier</td> </tr> <tr> <td>2</td> <td>It is easier to construct, as it requires less number of components</td> <td>It is not easy to construct, as it requires more number of components</td> </tr> <tr> <td>3</td> <td>It consumes less power</td> <td>It consumes more power</td> </tr> <tr> <td>4</td> <td>It is more stable</td> <td>It is less stable</td> </tr> <tr> <td>5</td> <td>It does not require feedback path element</td> <td>It requires feedback path element</td> </tr> <tr> <td>6</td> <td>It has poor accuracy</td> <td>It has better accuracy</td> </tr> <tr> <td>7</td> <td>It does not give automatic correction for external disturbances</td> <td>It gives automatic correction for external disturbances</td> </tr> <tr> <td>8</td> <td>It is more sensitive to noise</td> <td>It is less sensitive to noise</td> </tr> <tr> <td>9</td> <td>It is dependent on operating condition</td> <td>It is not dependent on operating conditions</td> </tr> <tr> <td>10</td> <td>Its operation is degraded if non linearity are present</td> <td>Its operation is not independent on conditions</td> </tr> <tr> <td>11</td> <td>It has slow response</td> <td>It has fast response</td> </tr> <tr> <td>12</td> <td>It has high bandwidth</td> <td>It has low bandwidth</td> </tr> </tbody> </table>	No.	Open Loop Control System	Close Loop Control System	1	It is simple and economical	It is complex and costlier	2	It is easier to construct, as it requires less number of components	It is not easy to construct, as it requires more number of components	3	It consumes less power	It consumes more power	4	It is more stable	It is less stable	5	It does not require feedback path element	It requires feedback path element	6	It has poor accuracy	It has better accuracy	7	It does not give automatic correction for external disturbances	It gives automatic correction for external disturbances	8	It is more sensitive to noise	It is less sensitive to noise	9	It is dependent on operating condition	It is not dependent on operating conditions	10	Its operation is degraded if non linearity are present	Its operation is not independent on conditions	11	It has slow response	It has fast response	12	It has high bandwidth	It has low bandwidth	<b>1 mark each point</b>	
No.	Open Loop Control System	Close Loop Control System																																								
1	It is simple and economical	It is complex and costlier																																								
2	It is easier to construct, as it requires less number of components	It is not easy to construct, as it requires more number of components																																								
3	It consumes less power	It consumes more power																																								
4	It is more stable	It is less stable																																								
5	It does not require feedback path element	It requires feedback path element																																								
6	It has poor accuracy	It has better accuracy																																								
7	It does not give automatic correction for external disturbances	It gives automatic correction for external disturbances																																								
8	It is more sensitive to noise	It is less sensitive to noise																																								
9	It is dependent on operating condition	It is not dependent on operating conditions																																								
10	Its operation is degraded if non linearity are present	Its operation is not independent on conditions																																								
11	It has slow response	It has fast response																																								
12	It has high bandwidth	It has low bandwidth																																								
<b>d)</b>	<b>Draw block diagram of Process Control System. Explain functions of each block.</b>		<b>04</b>																																							
<b>Ans</b>	<p><b>Automatic controller</b></p> <p><b>Explanation</b> - Process control system consists of process or plant ,sensor, error detector, automatic Controller, actuator or control element.</p> <p><b>1) Process or plant-</b> process means some manufacturing sequence. It has one variable or multivariable output. Plant or process is an important element of process control system in which variable of process is to be controlled.</p>	<b>2 Marks for diagram</b>	<b>2 Marks for explanation</b>																																							

2) **Sensor measuring elements** – It is the device that converts the output variable into another suitable variable which can be acceptable by error detector. Sensor is present in f/b path of close loop system.

3) **Error detector** – Error detector is the subtracting summing points whose output is an error signal i.e.  $e(t) = r(t) - b(t)$  to controller for comparison & for the corrective action. Error detector compares between actual signal & reference i/p i.e. set point.

4) **Automatic controller**- Controller detects the actuating error signal, which is usually at a very low power level, and amplifies it to a sufficiently high level i.e. means automatic controller comprises an error detector and amplifier.

5) **Actuator or control element** – Actuator is nothing but pneumatic motor or valve, a hydraulic motor or an electric motor, which produces an input to the plant according to the control signal getting from controller.

OR

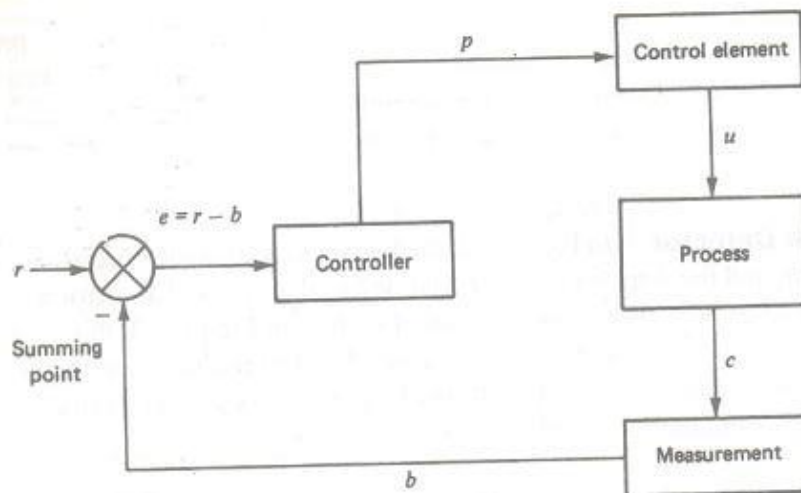

**Explanation :**

The block diagram of process control system consists of the following blocks:-

1) **Measuring element:** It measures or senses the actual value of controlled variable „c” and converts it into proportional feedback variable b.

2) **Error detector :** It receives two inputs: set point „r” and controlled variable „p”. The output of the error detector is given by  $e = r - b$ . „e” is applied to the controller.



	<p><b>3) Controller:</b> It generates the correct signal which is then applied to the final control element. Controller output is denoted by „p“.</p> <p><b>4) Final control element:</b> It accepts the input from the controller which is then transformed into some proportional action performed by the process. Output of control element is denoted by „u“.</p> <p><b>5) Process:</b> Output of control element is given to the process which changes the process variable. Output of this block is denoted by „u“.</p>		
<b>Q1 B)</b>	<b>Attempt Any One</b>		<b>06</b>
<b>a)</b>	<b>Explain the memory organization of PLC</b>		<b>06</b>
<b>Ans</b>	<p>Different types of memory that are generally used in PLC s are as follows:</p> <ol style="list-style-type: none"><li>1. RAM:</li><li>2. ROM: A.)EPROM B.)EEPROM</li></ol> <p>In PLC program instructions are stored in the memory. An internal communication high way also known as a bus system, carries information to and fro from the CPU, Memory and I/O units under the control of CPU Memory unit for storage of program.</p> <p>The user ladder logic program, is in the memory of PLC. The main program and other programs are necessary for operation of PLC. The organization of the data and information in the memory is called memory map</p> <p>There are two types of memory used in PLC: Volatile and non volatile memory , in non volatile memories are generally used for storing user program so that the programs can return during power failure.</p> <p>OR</p> <p>Memory is classified into two types:</p> <ol style="list-style-type: none"><li>1. Storage memory: in storage memory store information on the status of i/o devices, pre assigned value of internal relay status and values for mathematical functions, this is called a data table or register table and stores information in two types: status and numbers,. Status is stored in the form of ON or OFF and nos are stored in the form of 1"s and 0"s is unique bit of memory.</li><li>2. User memory: in this memory, ladder logic programming is carried out and stored. User memory consists of program files or register table and holds the</li></ol>		

	<p>complete operation.</p> <p>**Diagram is Optional</p>		
<p>b)</p>	<p><b>Draw the block diagram of DC Servo System. Explain function of each block.</b></p>		<p><b>06</b></p>
<p>Ans</p>	<p><b>Fig: DC Servo Motor</b></p> <p><b>Explanation</b></p> <ol style="list-style-type: none"> <li>1) The standard block diagram of servo system consists of error detector, amplifier, motor as controller, load whose position is to be changed.</li> <li>2) Servo systems is to be divided into two type a) DC servo systems b) AC servo system</li> <li>3) DC servo system consists of potentiometer as a error detector, DC amplifier, DC motor, DC gear system and the DC load whose position is to be changed.</li> <li>4) In DC servo system potentiometer has two input i.e one is reference</li> </ol>	<p><b>2 Marks for diagram</b></p> <p><b>4 Marks for explanation</b></p>	

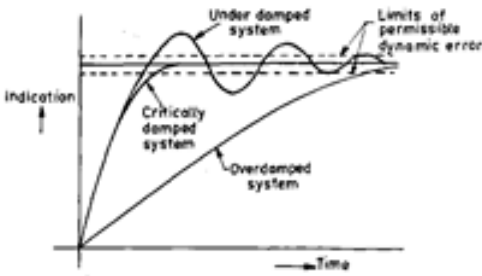

	$e_{ss}(t) = \lim_{s \rightarrow 0} \frac{s.R(s)}{1+s.G(s).H(s)} \dots \text{Here } H(S)=1$ <p>R(s) = 1 / S<sup>3</sup> for unit parabolic input</p> <p>So <math>e_{ss}(t) = \lim_{s \rightarrow 0} \frac{1/S^2}{1 + \frac{K(S+2)}{s^1(s^2+7s^1+12)}}</math></p> <p>After solving equation we get,</p> $e_{ss}(t) = \lim_{s \rightarrow 0} \frac{(s^2 + 7s^1 + 12)}{s^2 (s^2 + 7s^1 + 12) + K(S+2)} = \frac{6}{K}$	1 Mark																
<b>b)</b>	<b>Draw the time response of second order system. Explain effect of damping on response of second order system.</b>		<b>08</b>															
<b>Ans</b>	 <p style="text-align: center;"><b>Fig: Time response of second order system</b></p> <p><b>Damping :</b></p> <ol style="list-style-type: none"> <li>i) Damping is an influence within or upon an oscillatory system that has the effect of reducing, restricting or preventing its oscillations.</li> <li>ii) The damping ratio is a dimensionless measure describing how oscillations in a system decay after a disturbance.</li> <li>iii) The damping ratio is generally denoted by zeta ( ζ )</li> <li>iv) The damping ratio is a measure of describing how rapidly the oscillations decay from one bounce to the next.</li> </ol> <p><b>Effect of damping in response of 2<sup>nd</sup> order control system:</b></p> <table border="1" style="width: 100%; border-collapse: collapse;"> <thead> <tr> <th>No</th> <th>Range of ζ</th> <th>Type of close loop poles</th> <th>Nature of response</th> <th>System Classification</th> </tr> </thead> <tbody> <tr> <td style="text-align: center;"><b>1</b></td> <td style="text-align: center;">ζ = 0</td> <td>Purely imaginary</td> <td>Oscillations with constant amplitude &amp; frequency</td> <td>Undamped</td> </tr> <tr> <td style="text-align: center;"><b>2</b></td> <td style="text-align: center;">0 &lt; ζ &lt; 1</td> <td>Complex Conjugates with negative</td> <td>Damped Oscillations</td> <td>Underdamped</td> </tr> </tbody> </table>	No	Range of ζ	Type of close loop poles	Nature of response	System Classification	<b>1</b>	ζ = 0	Purely imaginary	Oscillations with constant amplitude & frequency	Undamped	<b>2</b>	0 < ζ < 1	Complex Conjugates with negative	Damped Oscillations	Underdamped	02 mark for diagram	02 mark for damping
No	Range of ζ	Type of close loop poles	Nature of response	System Classification														
<b>1</b>	ζ = 0	Purely imaginary	Oscillations with constant amplitude & frequency	Undamped														
<b>2</b>	0 < ζ < 1	Complex Conjugates with negative	Damped Oscillations	Underdamped														
		04 mark for response on system																



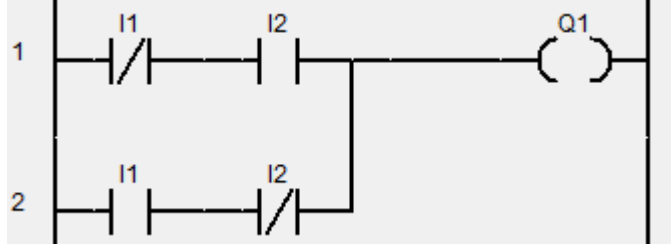

		real parts																																			
	3	$\zeta = 1$	Real, Equal and Negative	Critical & Pure exponential	Critically damped																																
	4	$1 < \zeta < \infty$	Real, equal & Negative	Purely exponential slow and sluggish	Overdamped																																
c)	<b>Draw ladder diagram to verify following logic gate truth table</b> a) NAND gate b) EX-OR gate c) NOR gate d) AND gate						<b>08</b>																														
Ans	i) NOR Gate for I1 & I2 Inputs  <table border="1" data-bbox="365 997 1104 1186"> <thead> <tr> <th>I1</th> <th>I2</th> <th>Q1</th> </tr> </thead> <tbody> <tr> <td>0</td> <td>0</td> <td>1</td> </tr> <tr> <td>0</td> <td>1</td> <td>1</td> </tr> <tr> <td>1</td> <td>0</td> <td>1</td> </tr> <tr> <td>1</td> <td>1</td> <td>0</td> </tr> </tbody> </table> ii) Ex-OR Gate for I1 & I2 Inputs  <table border="1" data-bbox="365 1543 1104 1732"> <thead> <tr> <th>I1</th> <th>I2</th> <th>Q1</th> </tr> </thead> <tbody> <tr> <td>0</td> <td>0</td> <td>0</td> </tr> <tr> <td>0</td> <td>1</td> <td>1</td> </tr> <tr> <td>1</td> <td>0</td> <td>1</td> </tr> <tr> <td>1</td> <td>1</td> <td>0</td> </tr> </tbody> </table> i) NOR Gate for I1 & I2 Inputs					I1	I2	Q1	0	0	1	0	1	1	1	0	1	1	1	0	I1	I2	Q1	0	0	0	0	1	1	1	0	1	1	1	0	01 Mark	
I1	I2	Q1																																			
0	0	1																																			
0	1	1																																			
1	0	1																																			
1	1	0																																			
I1	I2	Q1																																			
0	0	0																																			
0	1	1																																			
1	0	1																																			
1	1	0																																			
						01 Mark																															
						1 Mark																															
						01 Mark																															
						01 Mark																															

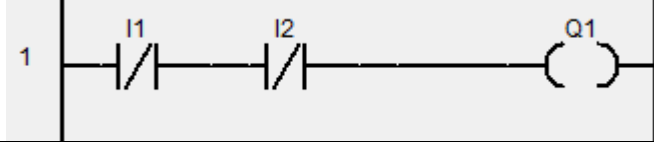
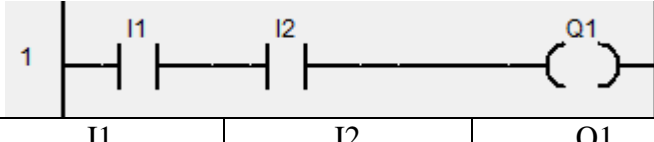

	<div style="text-align: center;">  </div> <table border="1" style="margin: 10px auto;"> <tr><td>I1</td><td>I2</td><td>Q1</td></tr> <tr><td>0</td><td>0</td><td>1</td></tr> <tr><td>0</td><td>1</td><td>0</td></tr> <tr><td>1</td><td>0</td><td>0</td></tr> <tr><td>1</td><td>1</td><td>0</td></tr> </table> <p>ii) AND Gate for I1 &amp; I2 Inputs</p> <div style="text-align: center;">  </div> <table border="1" style="margin: 10px auto;"> <tr><td>I1</td><td>I2</td><td>Q1</td></tr> <tr><td>0</td><td>0</td><td>0</td></tr> <tr><td>0</td><td>1</td><td>0</td></tr> <tr><td>1</td><td>0</td><td>0</td></tr> <tr><td>1</td><td>1</td><td>1</td></tr> </table> <p><b>Note: Any relevant ladder logic may considered.</b></p>	I1	I2	Q1	0	0	1	0	1	0	1	0	0	1	1	0	I1	I2	Q1	0	0	0	0	1	0	1	0	0	1	1	1	<p>01 Mark</p> <p>01 Mark</p> <p>01 Mark</p>	
I1	I2	Q1																															
0	0	1																															
0	1	0																															
1	0	0																															
1	1	0																															
I1	I2	Q1																															
0	0	0																															
0	1	0																															
1	0	0																															
1	1	1																															
<b>Q. 3</b>	<b>Attempt any four</b>		<b>16</b>																														
<b>a)</b>	<b>Compare Linear and non-linear system(any four points)</b>		<b>04</b>																														
<b>Ans</b>	<table border="1" style="width: 100%; border-collapse: collapse;"> <thead> <tr> <th style="width: 50%; text-align: center;">Linear System</th> <th style="width: 50%; text-align: center;">Non-Linear System</th> </tr> </thead> <tbody> <tr> <td>Obey superposition theorem/principle.</td> <td>Do not obey superposition theorem/principle.</td> </tr> <tr> <td>Can be analyzed by standard test input signal</td> <td>Cannot be analyzed by standard test input signal</td> </tr> <tr> <td>Do not exhibit limit cycles</td> <td>exhibit limit cycles</td> </tr> <tr> <td>Do not exhibit Hysteresis/ jump resonance.</td> <td>Exhibit Hysteresis/ jump resonance.</td> </tr> <tr> <td>Stability depends only on root location</td> <td>Stability depends only on root location, initial condition and type of input.</td> </tr> <tr> <td>Can be analyzed by Laplace, Fourier, Z transform</td> <td>Cannot be analyzed by these methods.</td> </tr> <tr> <td>e.g Potentiometer</td> <td>e.g Logarithmic amplifier</td> </tr> </tbody> </table>	Linear System	Non-Linear System	Obey superposition theorem/principle.	Do not obey superposition theorem/principle.	Can be analyzed by standard test input signal	Cannot be analyzed by standard test input signal	Do not exhibit limit cycles	exhibit limit cycles	Do not exhibit Hysteresis/ jump resonance.	Exhibit Hysteresis/ jump resonance.	Stability depends only on root location	Stability depends only on root location, initial condition and type of input.	Can be analyzed by Laplace, Fourier, Z transform	Cannot be analyzed by these methods.	e.g Potentiometer	e.g Logarithmic amplifier	<b>1 Mark for each point</b>															
Linear System	Non-Linear System																																
Obey superposition theorem/principle.	Do not obey superposition theorem/principle.																																
Can be analyzed by standard test input signal	Cannot be analyzed by standard test input signal																																
Do not exhibit limit cycles	exhibit limit cycles																																
Do not exhibit Hysteresis/ jump resonance.	Exhibit Hysteresis/ jump resonance.																																
Stability depends only on root location	Stability depends only on root location, initial condition and type of input.																																
Can be analyzed by Laplace, Fourier, Z transform	Cannot be analyzed by these methods.																																
e.g Potentiometer	e.g Logarithmic amplifier																																
<b>b)</b>	<b>Explain the functions of output module of PLC</b>		<b>04</b>																														
<b>Ans</b>	<ul style="list-style-type: none"> <li>Output devices are connected to PLC through output modules, that means it function as a medium that connects the external output devices such as Lamp, motor or solenoid etc. to the CPU within PLC.</li> <li>Information from PLC is always in the form of digital signals such as</li> </ul>	<b>02 marks for explana</b>																															

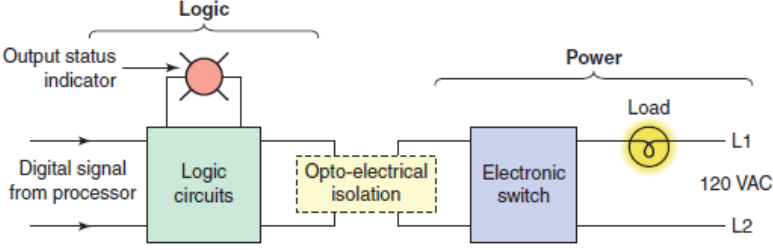
	<p>high or low, true or false or zero or one. This module is connecting the PLC to the output field devices.</p> <ul style="list-style-type: none"> <li>• Output devices used with PLC are Motor, display, solenoid, heater, lamps, relays, buzzer etc.</li> <li>• Output module also performs the four important functions.             <ol style="list-style-type: none"> <li>1. Signal conditioning.-</li> <li>2. Indication.-</li> <li>3. Termination.</li> <li>4. Isolation.</li> </ol> </li> </ul>  <p style="text-align: center;">Fig- Output module of PLC</p>	<p>tion</p> <p>02 for diagram</p>	
<p>c)</p>	<p><b>What is Laplace transform? Explain the significance of Laplace transform in control system.</b></p>		<p>04</p>
<p>Ans</p>	<p>Laplace Transform-</p> <p>The Laplace transform is defined in the following way. Let <math>f(t)</math> be defined for <math>t \geq 0</math>. Then the Laplace transform of <math>f</math>, which is denoted by <math>\mathcal{L}[f(t)]</math> or by <math>F(s)</math>, is defined by the following equation</p> $\mathcal{L}[f(t)] = F(s) = \lim_{T \rightarrow \infty} \int_0^T f(t)e^{-st} dt = \int_0^{\infty} f(t)e^{-st} dt$ <p>Significance-</p> <ul style="list-style-type: none"> <li>• Laplace transform converts the integro differential equation into simple algebraic equation in <math>s</math>, which may be real or complex.</li> <li>• Analysis of each component in the system is possible.</li> <li>• It is possible to manipulate the algebraic equation by simple algebraic rules to obtain the solution.</li> <li>• Initial conditions are automatically incorporated.</li> <li>• Both complementary and particular solution can be obtained in one operation, thus gives complete solution.</li> <li>• Allows the use of graphical techniques, for predicting the system performance without actual solving of system differential equations.</li> </ul>	<p>02 marks for definition</p> <p>02 marks for significance</p>	
<p>d)</p>	<p><b>Define:</b></p> <ol style="list-style-type: none"> <li><b>Stability</b></li> <li><b>Relative stability</b></li> </ol>		<p>04</p>
<p>Ans</p>	<p><u>Stability-</u></p>	<p>02 marks</p>	

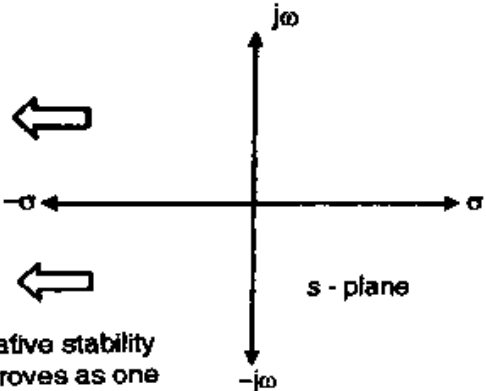

	<ul style="list-style-type: none"> <li>• The system is said to be stable if it produces bounded output for a bounded input.</li> <li>• It is used to define usefulness of the system.</li> <li>• The stability implies that the system performance should not change even if there is small change in system input. Any control system must be stable.</li> <li>• The system is said to be stable if poles of closed loop TF of the system lies in left half of s-plane</li> <li>• The system is said to be unstable if poles closed loop TF of the system lies in right half of s-plane</li> </ul> <p><b>Relative stability-</b></p> <ul style="list-style-type: none"> <li>• It is a quantitative measure of how fast the transient die out in the system.</li> <li>• Relative stability may be measured by relative settling times of each root or pair of roots.</li> <li>• The settling time of a pair of complex conjugate poles is inversely proportional to the real part of the root.</li> <li>• As the root moves further away from the imaginary axis the relative stability of the system improves.</li> </ul>  <p>Relative stability improves as one moves away from imaginary axis on half of s - plane</p> <p><b>Relative stability improvement area.</b></p>	<p><b>02 marks</b></p> <p><b>(only suitable explanation)</b></p>	
e)	<b>Define the scan time of PLC. Explain the significance of scan time.</b>		<b>04</b>
Ans	<p><b>Scan time-</b></p> <ul style="list-style-type: none"> <li>• The time taken by PLC to get from one I/O update to the next is known as PLC scan time.</li> <li>• It is typically measured in milliseconds (ms).</li> <li>• PLC scan time depends on number of inputs, outputs and program size (total memory used,).</li> </ul>	<p><b>02 marks</b></p>	

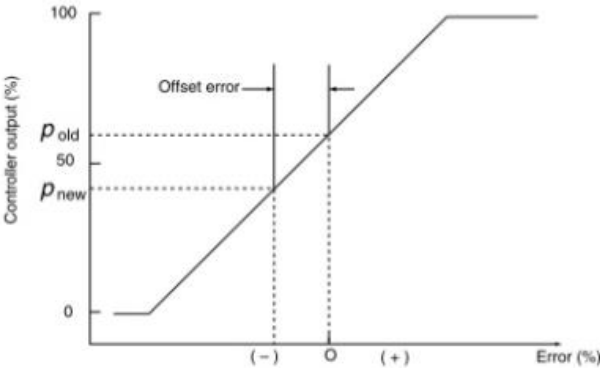
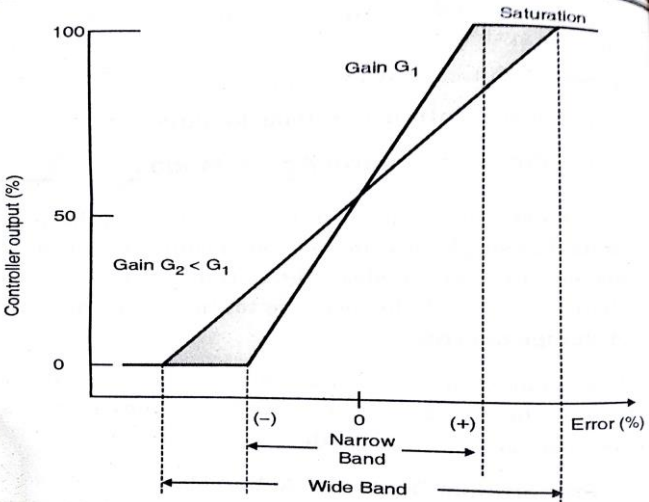
	<ul style="list-style-type: none"> <li>• So it may be different for different program (PLC).</li> </ul> <p><b>Significance-</b></p> <ul style="list-style-type: none"> <li>• Less scan time means faster PLC action.</li> <li>• It indicates the speed of CPU.</li> <li>• It indicates the speed of execution.</li> </ul>	<p><b>02 marks</b></p>	
<p><b>Q.4 A)</b></p>	<p><b>Attempt any three</b></p>		<p><b>12</b></p>
<p><b>a)</b></p>	<p><b>Explain the offset in proportional controller. Draw the response of proportional controller.</b></p>		<p><b>04</b></p>
<p><b>Ans</b></p>	<p><b>Offset in proportional controller-</b></p> <ul style="list-style-type: none"> <li>• Proportional controller produces a permanent residual error in the operating point of the controlled variable when a change is occurring.</li> <li>• This error is referred as Offset.</li> <li>• It can be minimized by a larger constant, <math>K_p</math>, which also reduces the proportional band.</li> </ul>  <p style="text-align: center;"><b>Fig- Offset.</b></p> <p><b>Response of proportional controller-</b></p> 	<p><b>02 marks</b></p>	



b)	List any four specifications of AC input module.		04														
Ans	<table border="1" data-bbox="240 327 1058 926"><thead><tr><th data-bbox="240 327 651 401">Item</th><th data-bbox="651 327 1058 401">Typical Value for 120/230 V AC</th></tr></thead><tbody><tr><td data-bbox="240 401 651 474">Rated voltage and current</td><td data-bbox="651 401 1058 474">120V at 64mA 230V at 9 mA</td></tr><tr><td data-bbox="240 474 651 548">Specified operational voltage range</td><td data-bbox="651 474 1058 548">264 V AC</td></tr><tr><td data-bbox="240 548 651 621">Signal delay</td><td data-bbox="651 548 1058 621">15.0 ms ON to OFF or OFF to ON</td></tr><tr><td data-bbox="240 621 651 737">Logic 1 minimum( Threshold values for ON and OFF conditions)</td><td data-bbox="651 621 1058 737">790 V AC at 2.5 mA</td></tr><tr><td data-bbox="240 737 651 852">Logic 0 minimum( Threshold values for ON and OFF conditions)</td><td data-bbox="651 737 1058 852">20 V AC at 1 mA</td></tr><tr><td data-bbox="240 852 651 926">Isolation between field to logic</td><td data-bbox="651 852 1058 926">1500 V AC for 1 sec.</td></tr></tbody></table> <p data-bbox="711 961 760 993" style="text-align: center;"><b>OR</b></p> <p data-bbox="240 999 919 1031">Any Other relevant specifications may considered</p>	Item	Typical Value for 120/230 V AC	Rated voltage and current	120V at 64mA 230V at 9 mA	Specified operational voltage range	264 V AC	Signal delay	15.0 ms ON to OFF or OFF to ON	Logic 1 minimum( Threshold values for ON and OFF conditions)	790 V AC at 2.5 mA	Logic 0 minimum( Threshold values for ON and OFF conditions)	20 V AC at 1 mA	Isolation between field to logic	1500 V AC for 1 sec.	01 mark each point	
Item	Typical Value for 120/230 V AC																
Rated voltage and current	120V at 64mA 230V at 9 mA																
Specified operational voltage range	264 V AC																
Signal delay	15.0 ms ON to OFF or OFF to ON																
Logic 1 minimum( Threshold values for ON and OFF conditions)	790 V AC at 2.5 mA																
Logic 0 minimum( Threshold values for ON and OFF conditions)	20 V AC at 1 mA																
Isolation between field to logic	1500 V AC for 1 sec.																
c)	Explain in detail the role of CPU in PLC.		04														
Ans	<ul data-bbox="289 1115 1230 1640" style="list-style-type: none"><li>• Central Processing unit is heart of PLC. CPU controls, monitors and supervises all operations within PLC.</li><li>• The CPU makes decision and executes control instruction based on the program instruction in memory.</li><li>• The processor has three operating modes-</li><li>• Program Mode—in this mode the processor allows the user to make changes in the program including entry and editing.</li><li>• Run Mode—the processor allows the user to execute the ladder program.</li><li>• REM—the processor is placed in remote mode. The user is allowed to edit the program and make changes in the program mode.</li><li>• It also carries out programmed instructions stored in the memory.</li><li>• An internal bus system, carries information to and from the CPU, memory and I/O units under the control of the CPU.</li></ul>	02 marks for explanation															

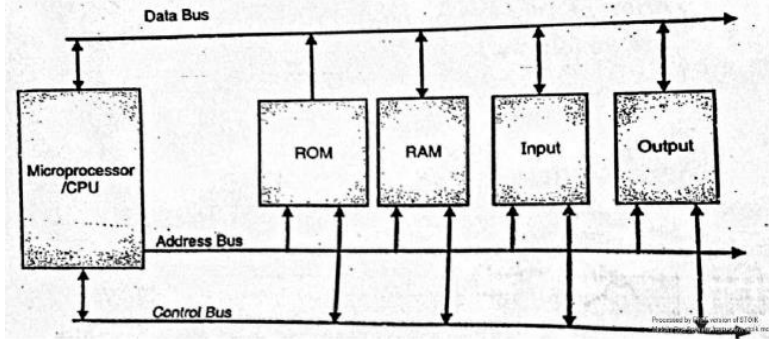

Fig- Block diagram of the processor section of a PLC.

02 marks for diagram

d) Write the Laplace transform for following input signal

- i. Step
- ii. Ramp
- iii. Parabolic
- iv. Impulse

04

Ans

Standard test input	Laplace Representation	Waveforms
Step input(position function) $r(t)$	L.T of $r(t) = R(s) = A/s$	
Ramp input(Velocity function) $r(t)$	L.T of $r(t) = R(s) = A/s^2$	
Parabolic input(Acceleration $r(t)$ function)	L.T of $r(t) = R(s) = A/s^3$	
Impulse input $r(t)$	L.T of $r(t) = R(s) = 1$ if $A=1$	

01 mark for each point

B) Attempt any one

06

a) List the timer instruction of PLC. Explain any one of them in detail

06

Ans Depending on the time delay and operation there are two types of timers



➤ **PLC timer-** (i) ON delay timer

(ii) OFF delay timer

➤ **Description (i)** ON delay timer

1) This instruction counts time interval when conditions preceding it in the rung are true. Produces an output when accumulated value reaches the preset value.

2) Use TON instruction to turn an output on or off after the timer has been on for a preset time interval. The Ton instruction begins to count time base intervals when the rung conditions become true.

3) The accumulated value is reset when the rung condition go false regardless of whether the timer has timed out.

**Instruction parameter-** Timer TON is 3 word element.

	15	14 13 12 11 10 9 8 7 6 5 4 3	
	2 1 0		
word 0	TT\EN	TT\EN DN	16 bit
word 1	preset value		16 bit
word 2	Accumulator value		16 bit

**Status bit explanation-**

i) **Timer done bit (bit13)-DN** is set when the accumulated value is equal to or greater than the preset value. It is reset when rung condition become false.

ii) **Timer enable bit (bit 14)-EN** is set when rung condition are true. It is reset when rung condition become false.

iii) **Timer timing bit (bit15)-TT** is set when rung conditions are true & the accumulated value is less than the preset value. It is reset when the rung conditions go false or when the done bit is set.

**Description (ii)** OFF delay timer

1) This instruction counts time interval when conditions preceding it in the rung are false. Produces low output when accumulated value reaches the preset value.

2) Use Toff instruction to turn an output on or off after the timer has been off for a preset timer has been off for a preset time intervals. The Toff instruction begins to count time base intervals when the rung makes a true to false to transition.

3) As long as rung conditions remains false the timer increments its accumulated value each scan until it reaches the preset value. The accumulated value is reset when the rung conditions go true regardless of whether the timer has timed out.





<p><b>Instruction parameter- Timer TOFF is 3 word element.</b></p> <table border="1" style="width: 100%; border-collapse: collapse;"> <tr> <td style="width: 15%;"></td> <td style="width: 15%; text-align: center;">15</td> <td style="width: 15%; text-align: center;">14</td> <td style="width: 15%; text-align: center;">13</td> <td style="width: 15%; text-align: center;">12</td> <td style="width: 15%; text-align: center;">11</td> <td style="width: 15%; text-align: center;">10</td> <td style="width: 15%; text-align: center;">9</td> <td style="width: 15%; text-align: center;">8</td> <td style="width: 15%; text-align: center;">7</td> <td style="width: 15%; text-align: center;">6</td> <td style="width: 15%; text-align: center;">5</td> <td style="width: 15%; text-align: center;">4</td> <td style="width: 15%;"></td> </tr> <tr> <td></td> <td></td> <td style="text-align: center;">3</td> <td style="text-align: center;">2</td> <td style="text-align: center;">1</td> <td style="text-align: center;">0</td> <td colspan="6"></td> <td></td> </tr> <tr> <td>word 0</td> <td>TT\EN</td> <td colspan="10">TT\EN DN</td> <td>16 bit</td> </tr> <tr> <td>word 1</td> <td>preset value</td> <td colspan="10"></td> <td>16 bit</td> </tr> <tr> <td>word 2</td> <td>Accumulat or value</td> <td colspan="10"></td> <td>16 bit</td> </tr> </table> <p><b>Status bit explanation-</b></p> <p><b>i) Timer done bit(bit13)-DN</b> is reset when the accumulated value is equal to or greater than the preset value. It is set when rung condition are true.</p> <p><b>ii) Timer enable bit(bit 14)-EN</b> is set when rung condition are true. It is reset when rung condition become false.</p> <p><b>iii) Timer timing bit(bit15)-TT</b> is set when rung conditions are false &amp; the accumulated value is less than the preset value. It is reset when the rung conditions go true or when the done bit is reset.</p>						15	14	13	12	11	10	9	8	7	6	5	4				3	2	1	0								word 0	TT\EN	TT\EN DN										16 bit	word 1	preset value											16 bit	word 2	Accumulat or value											16 bit		
	15	14	13	12	11	10	9	8	7	6	5	4																																																												
		3	2	1	0																																																																			
word 0	TT\EN	TT\EN DN										16 bit																																																												
word 1	preset value											16 bit																																																												
word 2	Accumulat or value											16 bit																																																												
<b>b)</b>	<b>Compare PI, PD and PID controller (four point).</b>					<b>06</b>																																																																		
<b>Ans</b>	<b>Sr. No.</b>	<b>PI</b>	<b>PD</b>	<b>PID</b>	1 ½ Marks for each point (Any four point)																																																																			
	<b>1</b>	It is the combination of Proportional control and integral control action	It is the combination of Proportional control and derivative control action	It is the combination of Proportional control, integral control and derivative control action																																																																				
	<b>2</b>	The proportional controller stabilizes the gain but produces steady state error and integral control minimize the error.	The proportional controller stabilizes the gain but produces steady state error and derivative control minimize the error.	The proportional controller stabilizes the gain but produces steady state error and integral and derivative control minimizes the error.																																																																				
	<b>3</b>	$P = K_p \cdot e_p + K_p K_i \int_0^t e_p(t) dt + P_i(0)$	$P = K_p \cdot e_p + K_p K_D \frac{d}{dx} (e_p) + P(0)$	$P(t) = k_p e(t) + k_p k_i \int_0^t e(t) dt + k_p k_d \frac{de(t)}{dt} + p(0)$																																																																				



4					
5	It eliminate steady state error.	It compensate rapidly changing error.	It eliminate steady state and rapidly changing error.		
6	It stabilize controller gain.	It increase controller gain during error change.	The gain of controller is stable.		
7	It require Expensive stabilization when process has many energy storage elements.	It cannot eliminate offset of proportional controller.	More effective for control process when many energy storage element than PI.		
8	It is used in control systems with large load changes.	It is used in temperature cascade systems and batch neutralization.	A PID controller can be used for regulation of speed, temperature, flow, pressure and other process variables.		
Q.5	Attempt any two				16
a)	<b>Draw the ladder diagram for 2 major operations</b> <b>i. When start button is pushed motor M<sub>1</sub> and M<sub>2</sub> start.</b> <b>ii. After 10 sec. motor M<sub>1</sub> stops.</b> <b>iii. Motor M<sub>2</sub> stops 15 sec. after motor M<sub>1</sub> has stopped.</b> <b>iv. Both M<sub>1</sub> and M<sub>2</sub> will stop when stop push button is pressed.</b>				08
Ans	List of inputs and there addresses Start button - 0/0 Stop button - 0/1 List of outputs and their addresses Motor (M <sub>1</sub> ) = 0; 0/0 Motor (M <sub>2</sub> ) = 0; 0/1 Off delay timer – T <sub>4</sub> :1				



	<p>Fig (i) and (ii)</p> <p>Fig (ii) and (iv)</p>	<p>04 marks</p> <p>04 marks</p>	
<p>b)</p>	<p>For a unity feedback system, the open loop T.F <math>G(S) = 25 / S(S+6)</math>  Determine,  i. Rise time  ii. Peak time  iii. Maximum overshoot  iv. Settling time.</p>		<p>08</p>
<p>Ans</p>	<p>The open loop transfer function for unity feedback system is given by</p> $\frac{C(S)}{R(S)} = \frac{G(S)}{1 + G(S)H(S)} = \frac{25}{1 + \frac{25}{S(S+6)} \cdot 1}$ $\frac{C(S)}{R(S)} = \frac{25}{S^2 + 6S + 25} \dots\dots\dots (1)$ <p>Comparing equation (1) with standard equation</p> $S = \frac{w_n^2}{2\xi w_n S + w_n^2}$	<p>01 mark</p>	



	<p>We get,  <math>W_n^2 = 25</math>                  So, <math>W_n = 5</math> rad/sec.</p> <p><math>2\xi W_n = 6</math>;                  So, <math>\xi = 0.6</math> rad/sec.</p> <p><math>W_d = 5\sqrt{1 - (0.6)^2}</math>  <math>W_d = 4</math> rad/sec.</p> <p>i. <b>Raise time</b>  <math>t_r = \pi - \beta</math>  <b>where,</b>  <math>\beta = \frac{\sqrt{1 - \xi^2}}{\xi}</math>  <math>t_r = \frac{3.14 - 1.33}{3.16}</math>  <math>\beta = \frac{0.8}{0.6} = 1.33</math>  <math>t_r = 0.572 \text{ sec}</math></p> <p>ii. <b>Peak time</b>  <math>t_p = \frac{\pi}{W_d} = \frac{3.14}{4}</math>  <math>t_p = 0.785 \text{ sec}</math></p> <p>iii. <b>Maximum overshoot</b>  <math>M_p \% = 100 * e^{\frac{-\pi\xi}{\sqrt{1-\xi^2}}}</math>  <math>= 100 * e^{\frac{-(3.14*0.6)}{\sqrt{1-0.06^2}}}</math>  <math>= 100 * e^{-2.355}</math>  <math>M_p \% = 9.48</math></p> <p>iv. <b>Settling time</b>  <math>T_s = \frac{4}{\xi W_n} = \frac{4}{0.6 * 5}</math>  <math>T_s = 1.33 \text{ sec}</math></p>	<p>01 mark</p> <p>01 mark</p> <p>01 mark</p> <p>01 mark</p> <p>01 mark</p> <p>01 mark</p> <p>01 mark</p>	
c)	<p>i. <b>Define critically stable and conditionally stable system.</b>                  ii. <b>For the characteristic equation</b>  <math>S^4 + 20KS^3 + 5S^2 + (10+K)S + 15 = 0</math> <b>determine value of K for stable system.</b></p>		08
Ans	<p>i. <b>Definition</b>  <b>Critically stable system:</b> A linear time invariant system is called as</p>	02 mark	

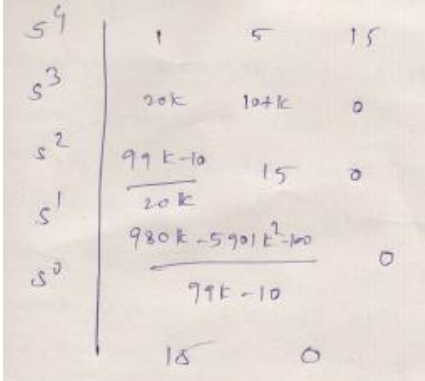

	<p>critically stable system if it generates oscillations with constant amplitude and frequency for a bounded input.</p> <p><b>Conditionally stable system:</b> a linear time invariant system is called as Conditionally stable system if the stability of such system depends on condition of parameters of the system.</p> <p><b>ii. For the characteristic equation <math>S^4 + 20KS^3 + 5S^2 + (10+K)S + 15 = 0</math> determine value of K for stable system.</b></p> <p>From the given characteristic equation we can write Routh's array</p>  <p>Consider Row <math>S^2</math>  <math>99K - 10 / 20K &gt; 0</math>  <math>99K - 10 &gt; 0</math>  <math>99K &gt; 10</math>  <math>K &gt; 10/99</math>  <math>K &gt; 0.1</math>          So value of K for stability should be greater than 0.1</p>	<p>02 mark</p> <p>04 marks</p>	
<p><b>Q.6</b></p>	<p><b>Attempt any four</b></p>		<p><b>16</b></p>
<p><b>a)</b></p>	<p><b>Explain in brief ON-OFF control action.</b></p>		<p><b>04</b></p>
<p><b>Ans</b></p>	<p>This is the most elementary controller mode which has only two fixed position ON and OFF . positions are commonly used two positions in most of the control systems.</p> <p>In this mode, when the error signed <math>e(t)</math> greater than the set point <math>r(t)</math>, the error signal is less than the set point the output maximizes. Fig (1) shows an iron which is an example of the ON/OFF control action, in this system there are only two stages of the output i.e. either the heater coil turn ON or OFF.</p> <p>In this the real time temperature is compared with the set point and error signal is generated by the controller to activate the relay, which ON/OFF the coil supply.</p>	<p>02 marks</p>	



		02 marks	
b)	<p><b>State the Routh's criteria, Describe different cases to find stability of system.(Any two)</b></p>		04
Ans	<p>The necessary &amp; sufficient condition for system to be stable is "All the terms in the first column of routh array must have same sign. There should not be any sign change in the first column of Routh's array".</p> <p>If there are any sign changes existing then,</p> <ol style="list-style-type: none"> <li>(1) System is unstable</li> <li>(2) The number of sign changes equals the number of roots lying in the right half of the S- plane.</li> </ol> <p><b>Case 1:</b> If first element of any row in the Routh's array is zero, while the rest of row has at least one non zero term then due to this the next row element becomes infinite and Routh's test fails. E.g. characteristics equation <math>F(S) = S^5 + S^4 + 2S^3 + 2S^2 + 3S + 5 = 0</math>. For this equation Routh's array is,</p> $  \begin{array}{c ccc}  S^5 & 1 & 2 & 3 \\  S^4 & 1 & 2 & 5 \\  S^3 & 0 & -2 & 0 \\  S^2 & \infty & &   \end{array}  $ <p>As third row element is zero the next row element becomes (infinity) and Routh's array fails.</p>	01 mark	1 1/2 Marks

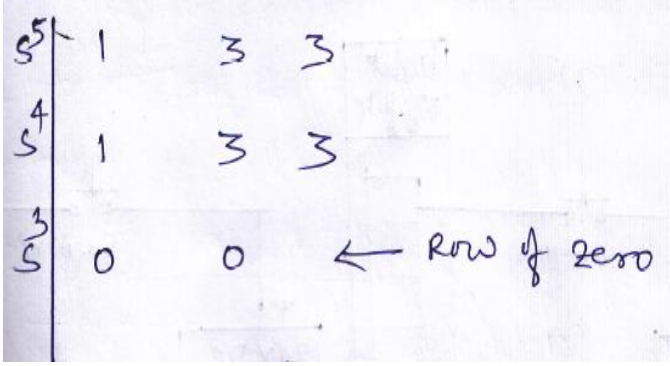
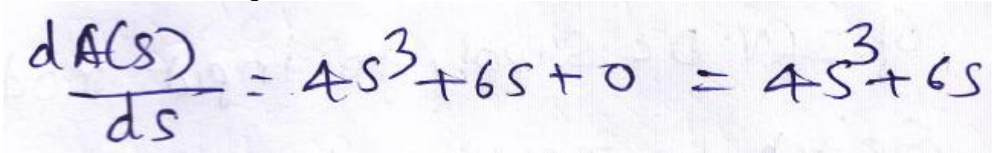

	<p><b>Case 2:</b> If all the element of a row are zero then due to this the elements of the next row cannot be determined and Routh's test fails. E.g. <b>characteristics equation</b> <math>F(S) = S^5 + S^4 + 3S^3 + 3S^2 + 3S + 3 = 0.</math> For this equation Routh's array is,</p>  <p>Here, a row <math>S^3</math> has all zero element, Routh's array test break down. To overcome a problem an auxiliary equation with polynomials is formed from the co-efficient of the <math>S^4</math>- row which is given by <math>A(S) = S^4 + 3S^2 + 3.</math> Differentiate this equation w.r.t S</p>  <p>Zeros in <math>S^3</math> row are now replaced by the co-efficient 4 &amp; 6.</p>	1 ½ marks	
c)	<b>With the help of neat diagram explain the concept of sourcing and sinking DC input module of PLC.</b>		<b>04</b>
Ans	<b>Diagram:</b>	02 marks	

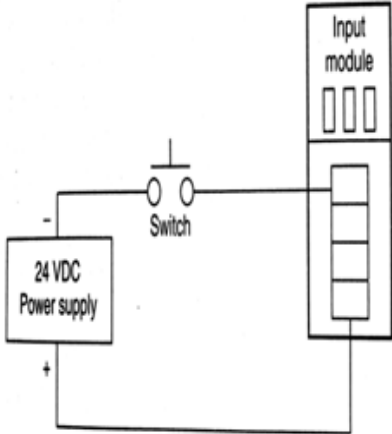
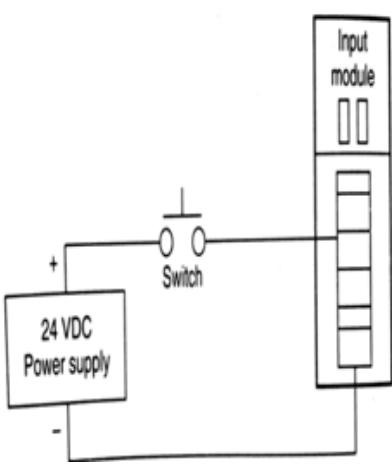
	<div style="display: flex; justify-content: space-around;"> <div style="text-align: center;">  <p><b>fig 1-Sourcing D.C input module with a sinking switch</b></p> </div> <div style="text-align: center;">  <p><b>Fig 2 - Sinking D.C input module with a sourcing switch</b></p> </div> </div> <p><b>➤ Explanation</b></p> <ol style="list-style-type: none"> <li>1. Sinking and Sourcing are terms used to describe current flow through a field device in relation to the power supply and the associated input, output point.</li> <li>2. Solid state input devices with NPN transistors are called “Sinking input device” while input devices with PNP transistor are called “Sourcing input devices”.</li> <li>3. In fig. no1 current flows from positive terminal of 24 volt DC supply to input module then through switch to negative terminal of supply, hence module acts as sinking device for DC supply but sourcing device for switch.</li> <li>4. In fig.2 current flows from positive terminal of 24 volt DC supply to switch then input module to negative terminal of supply, as far as input module is concern it act as sinking device for DC switch and sourcing device for 24 volt DC supply.</li> </ol>	<p><b>for diagram</b></p> <p><b>02 marks for explanation</b></p>	
<p><b>d)</b></p>	<p><b>Explain the derivate control action with equation and response curve. Why derivate action cannot be used alone.</b></p>		<p><b>04</b></p>
<p><b>Ans</b></p>	<p>As the name indicates in this mode the output of the controller is proportional to derivate of the input error signal.</p>		

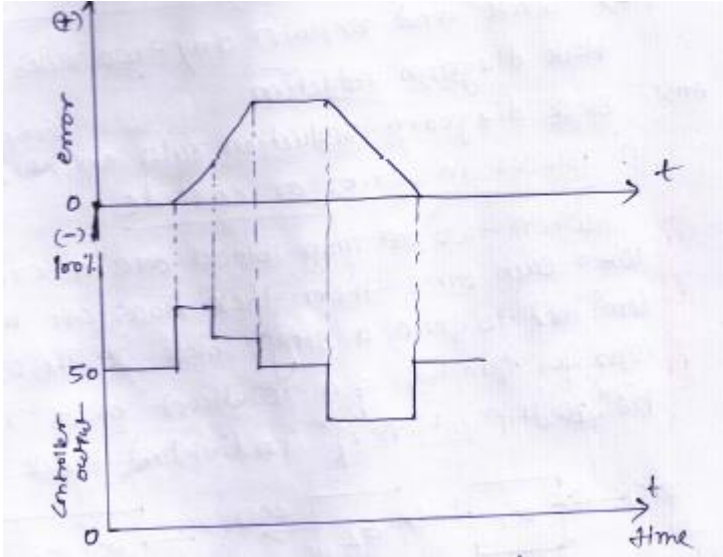
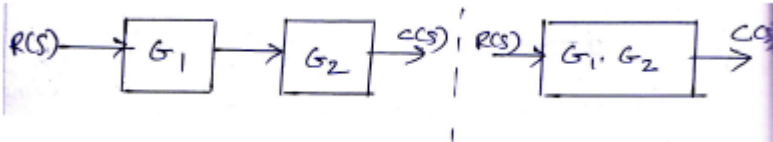

	 <p>Fig. Response curve of derivative mode.          Derivative controller action responds to the rate at which the error is changing, that is the derivative of the error.          Mathematically this mode is given by</p> $P(t) = K_D \frac{de(t)}{dt}$ <p>Where gain <math>K_D</math> tells us by how much % to change the controller output for every %/ sec rate of change of error.</p> <p>Derivative action is not used alone because it provides no output when error is constant.</p>	<p>02 marks for response curve</p> <p>01 mark for equation</p> <p>01 mark</p>	
<p>e)</p>	<p><b>State and explain any two rules of block diagram reduction.</b></p>		<p><b>04</b></p>
<p>Ans</p>	<p><b>Block diagram reduction rules are as follows:</b></p> <p>1. <b>Blocks in series or cascade:</b>          When two or more blocks are in series with each other then these blocks can be combine to form a single block.          The overall transfer function of a resultant block is given be multiplication of individual block</p>  <p>2. <b>Blocks in parallel:</b>          When two or more blocks are in parallel with each other then these blocks can be combine to form a single block.</p>	<p><b>02 marks for each rule (maximum 04 marks)</b></p>	

The overall transfer function of a resultant block is given by addition or difference of individual block transfer function as shown in figure.

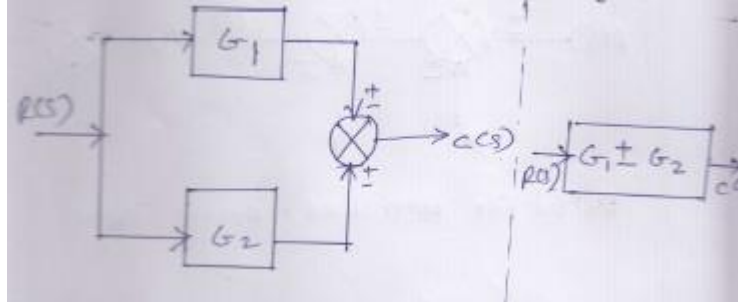

**3. Removal of minor or simple feedback loop:**

When a minor loop is present in a given system the minor feedback loop is converted into single functional block as shown in figure. The overall transfer function of system is given by

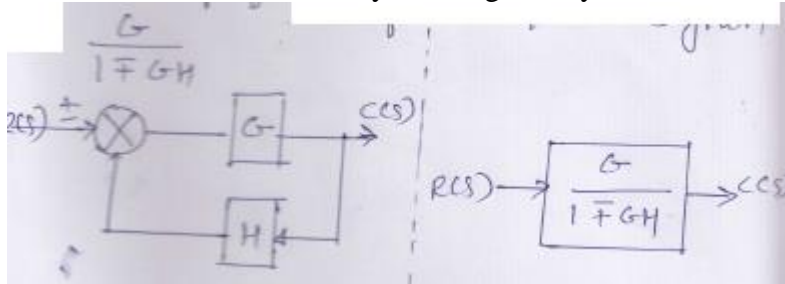

**4. Interchange of summing points:**

When two or more summing point are directly connected with each other, then these summing points can be interchanged. The output remains same in this case.

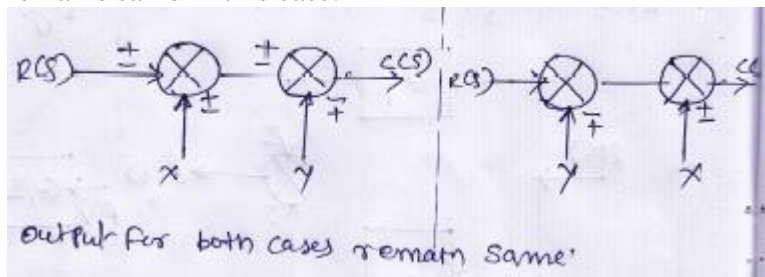

OR

Any two relevant rules of block diagram reduction shall be considered