



Summer – 14 EXAMINATION  
Model Answer

Subject Code: 17430

Page 1/ 24

**Important Instructions to examiners:**

- 1) The answers should be examined by key words and not as word-to-word as given in the model answer scheme.
- 2) The model answer and the answer written by candidate may vary but the examiner may try to assess the understanding level of the candidate.
- 3) The language errors such as grammatical, spelling errors should not be given more Importance (Not applicable for subject English and Communication Skills).
- 4) While assessing figures, examiner may give credit for principal components indicated in the figure. The figures drawn by candidate and model answer may vary. The examiner may give credit for any equivalent figure drawn.
- 5) Credits may be given step wise for numerical problems. In some cases, the assumed constant values may vary and there may be some difference in the candidate's answers and model answer.
- 6) In case of some questions credit may be given by judgement on part of examiner of relevant answer based on candidate's understanding.
- 7) For programming language papers, credit may be given to any other program based on equivalent concept.

**Q.1.**

**a) Attempt any six of the following:**

**i. Define baud rate and bits per seconds.**

Baud rate – 1M; bps – 1M

Baud rate: The baud rate is the number of times the **signal level** changes in a channel per second.

Bit rate or bits per second (bps): This is the number of **bits** transmitted per second in a channel.

**ii. List different error detection methods.(1/2 M each)**

Error Detection Methods

- a. VRC(Vertical redundancy Check) or Parity Check
- b. Longitudinal Redundancy Check (LRC)
- c. Cyclic Redundancy Check (CRC)
- d. Checksum method

**iii. What is piconet in Bluetooth architecture?(2M any two points)**

- Piconet means a small net.
- Piconet can have up to eight stations, one of which is primary, rest are called secondaries.
- All secondary stations synchronize their clocks and hopping sequence with primary.
- Piconet can only have one primary station.
- Communication between primary and secondary can be one to one or one-to many.
- Although piconet has a maximum seven secondaries, an additional eight secondaries can be in parked state.
- A secondary in a parked state is synchronized with primary, but cannot take part in communication until it is moved from the parked state.



**Summer – 14 EXAMINATION**  
**Model Answer**

Subject Code: 17430

Page 2/ 24

**iv. What is peer to peer process?(2Marks)**

In OSI model the processes on each machine that communicate at a given layer are called peer to peer processes. Communication between machines is therefore a peer to peer process using the protocol appropriate to a given layer.

**v. Define protocol and list different elements of protocol. (Definition 1M, List 1 M)**

Protocol: Protocol is a set of rules that govern data communication. It represents an agreement between the Communication devices. Without a protocol two devices may be connected but not communicating.

Elements of protocol are

- a) Syntax (what is to be communicated)
- b) Semantics (how is it to be communicated)
- c) Timing (When it should be communicated)

**vi. What is SMDS?(2 Marks)**

- Switched Multimegabit Data Services is a high speed MAN technology.
- It is high speed service for organizations having a number of LANs spread across different locations in a city.

**vii. List any two problems in internet working.(2Marks any two points)**

Problems in internetworking:

1. Multiple network technologies not satisfying all conditions
2. Increase in no of users resulting in decreased bit rate
3. Traffic congestion
4. No transparency in working with application
5. Not providing a platform where no hardware interconnections to be understood by users
6. Having no security.
7. Drop in the packets sent from one user to another

**viii. State the functions of name resolver in DNS.(2Marks any two points)**

Function of the Resolvers is as follows:

1. To generate DNS query.
2. To read the reply of the server.
3. To send this information back to the application who made resolver generate the DNS query.
4. It maintains a clock from generation of query to reply to it from server.
5. It resends the query if there is no reply from the server within a specific time period.

Summer – 14 EXAMINATION

Model Answer

Subject Code: 17430

b) Attempt any Two of the following:

i. Explain isochronous communication. (Diagram 2 M, Explanation 2 M)

This method combines the approaches of asynchronous and synchronous communication. In this method, as in the asynchronous method, each character has both the start and stop bits. However the idle period between the two characters is not random. For instance, all idle periods of no transmission consist of an exact multiple of one character time interval. Therefore, if the time to transmit a character (including its parity, start, stop bits) is  $t$ , the time interval between characters cannot be random as in asynchronous method. It is also not 0 as in synchronous methods. It has to be  $t, 2t, 3t, \dots, nt$  where  $n$  is a positive integer in isochronous communication.

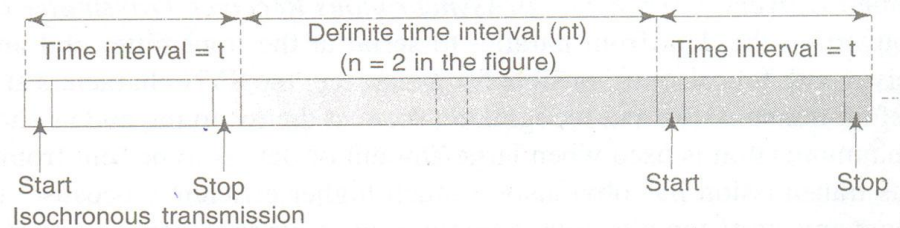

ii. Explain fiber optic cable construction. (Diagram 2M, Explanation 2M)

- 1) Fiber-Optic Cable :
- 2) An optical fiber is like a wire but it is very thin as compared to wire and it is made of glass. An optical fiber cable consists of a group of optical fibers packed together.

The optical fiber consists of three parts.

1. **Glass core:** - The innermost layer in an optical fiber cable is the glass core. The light rays pass through this innermost glass core.
2. **Cladding layer:** - The innermost glass layer is covered by the cladding layer. This layer is also made up of glass. But the refractive index of this layer is less than that of core layer.

The cladding layer performs the following functions:

It provides strength to the optical fiber cable.

The cladding layer acts like a mirror. It will reflect the light rays and will not allow them to escape outside the fiber.

When many optical fibers are packed in one cable the cladding layer avoids the interference between the light rays in the adjacent fibers.

**3. Jacket layer or Protective layer :-**

- i. Outmost layer in an optical fiber.
- ii. Provides mechanical strength to the optical cable.
- iii. Provides protection against environmental factors

Fiber-optic cable transmits light signals rather than electrical signals. It is enormously more efficient than the other network transmission media. Each fiber has an inner core of glass or plastic that conducts light. The inner core is surrounded by cladding. A layer of glass that reflects the light back into the core.

Summer – 14 EXAMINATION  
Model Answer

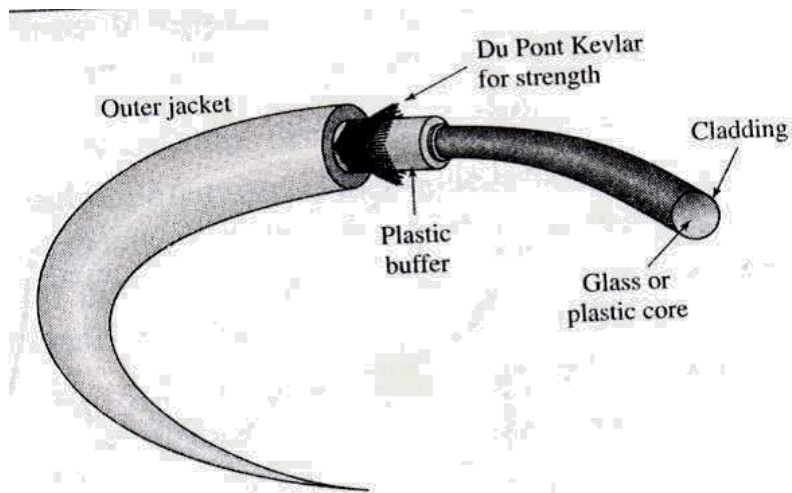

or

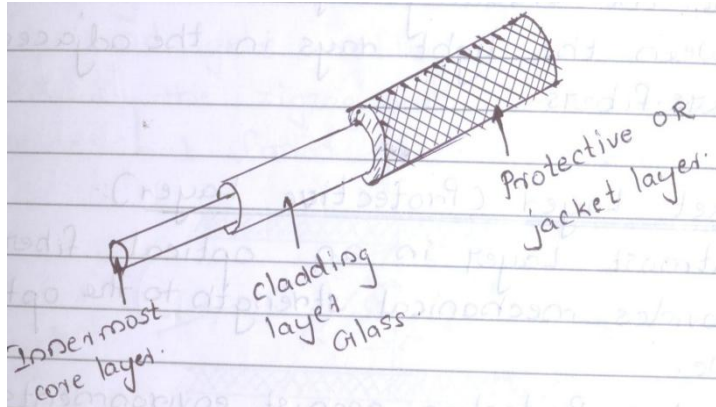

Or

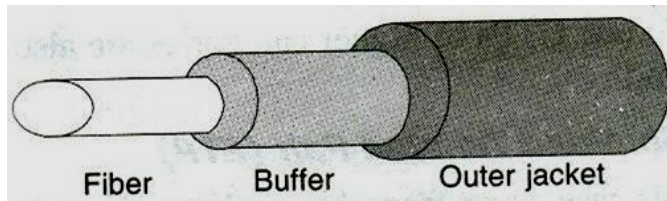

iii. What is token ring? Explain token ring passing mechanism. (Diagram 2m, Explanation 2M)

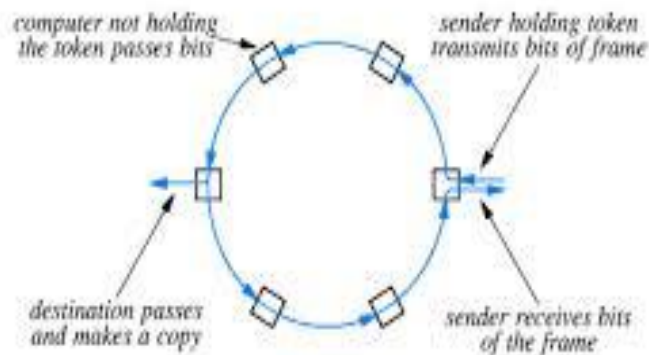

**Summer – 14 EXAMINATION**

**Model Answer**

Subject Code: 17430

- Every computer is connected to the next computer in the ring, and each retransmits what it receives from the previous computer.
- The message flow around the ring in one direction since each computer retransmits what it receives; a ring is an active network and is not subject to the signal loss problems a bus experience.
- There is no termination because there is no end to the ring.
- Some ring network do token passing. A short messages is called token is passed around the ring until a computer wishes to send information to another computer. That computer modifies the token, adds an electronic address and data, and sends it around the ring. Each computer in sequence receives the token and the information and passes them to the next computer until either the electronic address matches the address of a computer or the token returns to its origin. The receiving computer returns a message to the originator indicating that the message has been received. The sending computer then creates another token and places it on the network, allowing another station to capture the token and being transmitting. The token circulates until a station is ready to send and capture the token. This all happen very quickly

**Q.2. Attempt any four of the following:**

**a) Compare FDM versus TDM.(any four each 1Mark)**

FDM	TDM
FDM used for analog signals	FDM used for digital signals
FDM allows baseband media to allow data to flow in different directions on single medium at same time	TDM Divides single channel into multiple time slots
In FDM terminal with different speed and synchronization methods cannot be combine	In TDM intermixing of terminal with different speeds and synchronization methods is possible. And hence more flexible.
It is simpler to implement	It is difficult to implement.
FDM is used where a few low speed channel are desired	TDM is used with all types of transmission including voice image, picture and data

**b) Explain virtual packet switching.(Diagram 2M, explanation 2M)**

A single route is chosen path way sender and receiver at the beginning of the session when data is sent, all the packets of the transmission travel one after other along the same route.

1. Switched Virtual Circuit(SVC)

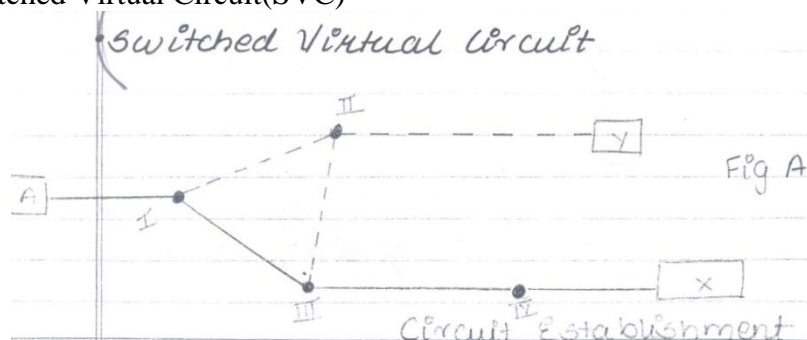

Summer – 14 EXAMINATION  
Model Answer

Subject Code: 17430

Page 6/ 24

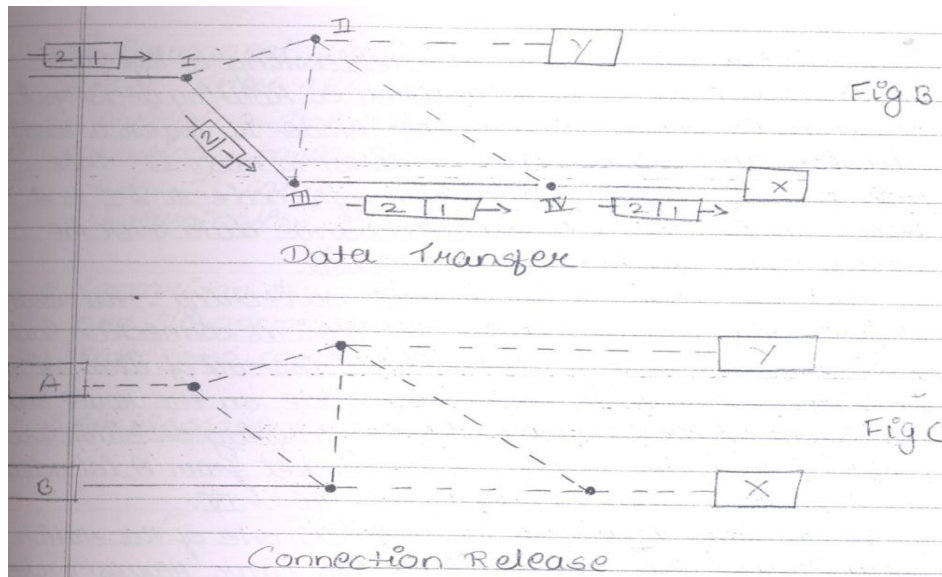

SVC format is comparable to dial up lines in circuit switching. A. VC is created when it is needed and exist only for the duration of specific exchange. Consider A has 1 or more messages to be sent to X it sends a special control packet called as call request packet to s/w I requesting a logical connection to X. Node I makes a routing decision and request is send to node III. Node III makes a routing decision and sends the request to Node IV. This packets is passed back through Node III and I to A . Now station A & X can exchange data over the route that has been established.

It is similar to circuit switching. So the route is fixed for the duration of logical connection. Each packet contains a VC identifier instead of destination address along with data. Each node on the route know where to direct the packet, no routing decisions are required. Thus every data packet from A intended to X passes through nodes I,III & IV. When data transfer is complete one of the stations terminates the connection with clear request packet. At the same time each station can have more than one VC to another station.

c) **Explain internal architecture of ISP.(Diagram 2M, Explanation 2M)**

As fig shows, a subscriber of an ISP connects to one of the telephone lines of the ISP via a modem. The ISP's modem then routes the subscriber to remote Access Server (RAS) to authenticate him. Once the user is authenticated, he is as good as connected to the internet. After this, the user can send requests for web pages, send/receive email or files, etc. the user's interaction with the internet is coordinated by the RAS.

In the figure an SMTP server at the top. The ISP needs this server for storing the subscriber's emails until the time the subscriber connects to the internet. When a user subscribe to the services of an ISP, the ISP optionally allows the user to create an email id and use it for sending/ receiving emails.

Web server can serve two purposes. Firstly, it can be used by the ISP to set up a portal. Secondary, this web server can be used to store the web pages created by the subscribers.

The RAS connects to a couple of routers. These routers essentially route the user's requests for web pages etc to the internet.

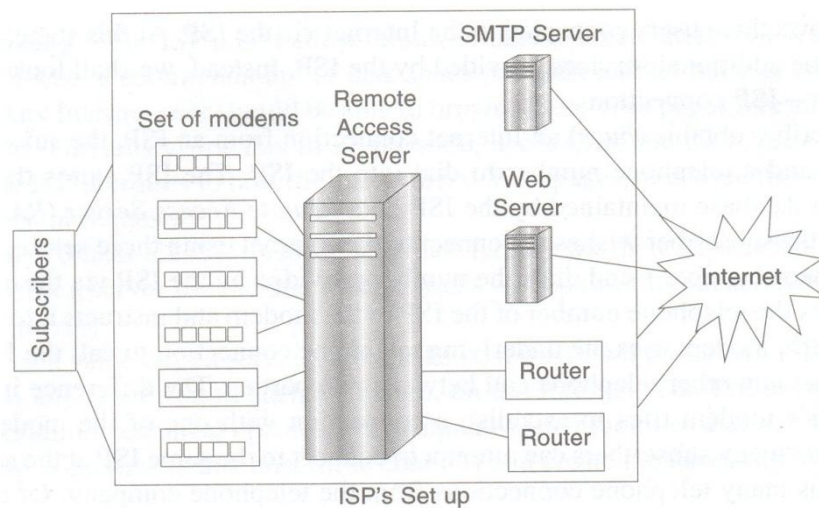

**d) Describe router with neat and label diagram. (Diagram 2M, Explanation 2M)**

1. A router is a specialized computer connected to more than one n/w
2. Router operate at the n/w layer
3. The primary function of a router is to connect n/w together & keep layer 2 broadcast traffic under control.
4. A router is typical connected to at least two n/w commonly two LAN OR WAN or LAN and its ISP s n/w or more n/w connects.
5. Routers are located at gateways, the places where two or more n/w connect.

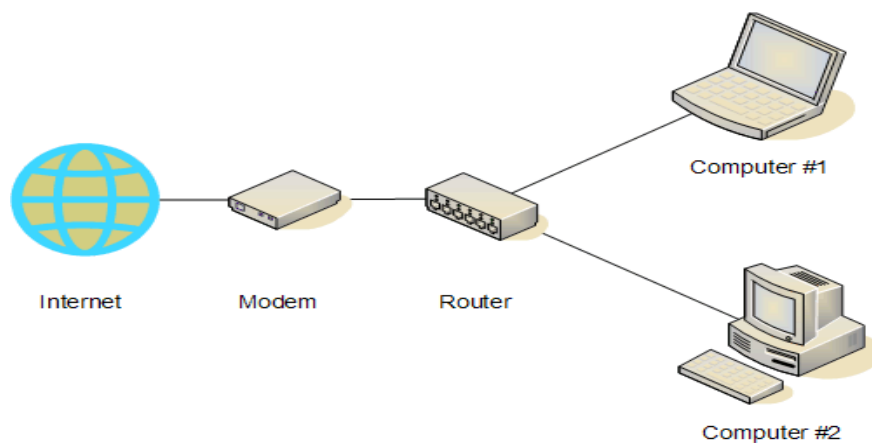

**e) Explain IEEE 802.11 standard.(Diagram 2M, Explanation 2M)**

IEEE 802.11 protocol architecture:

IEEE has defined the specifications for a wireless LAN, called IEEE 802.11, which covers the physical and data link layers.

The standard defines two kinds of services: the basic service set (BSS) and extended service set (ESS).

**Basic Service Set (BSS):** BSS is Building Blocks of wireless LAN. BSS is made of stationary or mobile wireless stations and an optional central base station. BSS without an AP is an ad hoc architecture and with an AP is an infrastructure.

Summer – 14 EXAMINATION  
Model Answer

Subject Code: 17430

Page 8/ 24

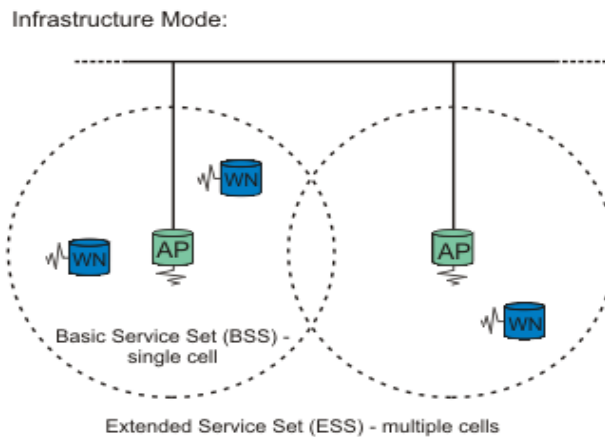

Types of BSS:

- 1) BSS without AP
- 2) BSS with AP

**Extended Service Set (ESS):** ESS is made up of two or more BSSs with APs. In ESS the BSSs are connected through a distribution system. The distribution system connects the APs in the BSSs.

f) Draw OSI reference model. Describe working of session and presentation layer.(diagram 2M, session layer 1M, presentation layer 1M)

Open Systems Interconnection (OSI) is a standard reference model for communication between two end users in a network. The model is used in developing products and understanding networks.

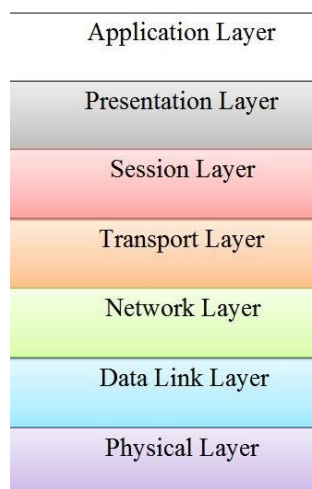

OSI divides telecommunication into seven layers. The layers are in two groups. The upper four layers are used whenever a message passes from or to a user. The lower three layers are used when any message passes through the host computer. Messages intended for this computer pass to the upper layers. Messages destined for some other host are not passed up to the upper layers but are forwarded to another host. The seven layers are:



Summer – 14 EXAMINATION  
Model Answer

Subject Code: 17430

Page 9/ 24

**Presentation Layer:** The Presentation layer is responsible for protocol conversion, data encryption/decryption, Expanding graphics command and the data compression. This layer makes the communications between two hosts possible.

**The responsibilities of the presentation layer are as follow:**

- **Translation:**  
The translation between the sender's and the receiver's message formats is done by the presentation layer if the two formats are different.
- **Encryption:**  
The presentation layer performs data encryption and decryption for security.
- **Compression:**  
**For efficient transmission, the presentation layer performs data compression before sending and data compression at destination.**

**Session Layer:** This layer is responsible for establishing the process-to-process communication between the hosts in the network. This layer is responsible for establishing and ending the sessions across the network. The interactive login is an example of services provided by this layer in which the connective is re-connected in case of any interruption.

**Session layer:** Establishes, maintains, synchronizes the interaction among communication systems It is responsible for dialog control and synchronization 1) Dialog control: Allows communication between two process to take place in half duplex (one way at a time) or full duplex (2 ways at a time)

2) Synchronization, session and sub session: session layer decides the order in which the data needs to be passes tp transport layer. Sessions are divided in to sub sessions for avoiding retransmission of entire message by adding check points.

**Q.3. Attempt any FOUR of the following:**

a) **State any two advantages of bus topology. Explain whether adding more computers in bus topology affects performance of network.**

(2 advantages 2M and performance of network 2 Marks)

**Advantages of Bus Topology:**

- 1) It is easy to set-up and extend bus network.
- 2) Cable length required for this topology is the least compared to other networks.
- 3) Bus topology costs very less.
- 4) Linear Bus network is mostly used in small networks. Good for LAN.

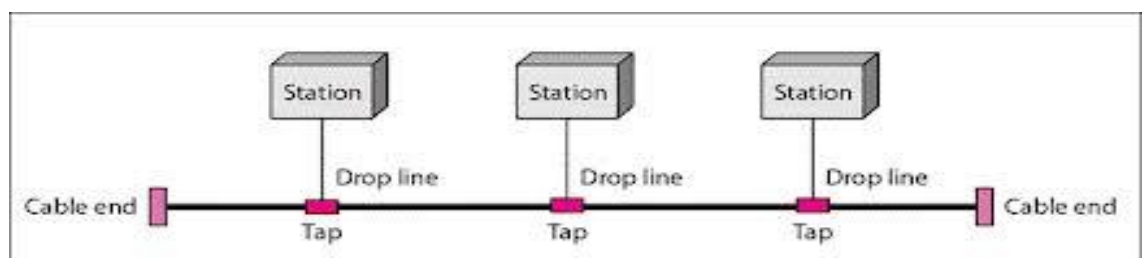

Adding more computers in bus topology affects performance of network because a bus topology designed to be optimally efficient at installation. It can be difficult to add new devices. Signal reflection at the taps can cause degradation in quality. This degradation can be controlled by limiting the number and spacing of devices connected to a given

Summer – 14 EXAMINATION  
Model Answer

Subject Code: 17430

Page 10/ 24

length of cable. Adding new devices may therefore require modification or replacement of the backbone.

**b) What are different types of transmission media?( Guided Media 2M, Unguided Media 2M)**

The different types of transmission media are:

1) Guided Media :

A signal travelling along any of these media is directed and contained by the physical limits of the medium. Twisted pair and coaxial cable use metallic conductors that accept and transport signals in the form of electric currents. Optical fiber is a cable that accepts and transports signals in the form of light.

- a. Twisted Pair wires
- b. Coaxial cables
- c. Optical fiber

2) Unguided Media:

Unguided media transport electromagnetic waves without using a physical conductor. Signals are normally broadcast through free space and thus are available to anyone who has a device capable of receiving them.

- a. Microwave (Terrestrial and Satellite )
- b. Broadcast Radio Waves
- c. Infrared

**c) Explain multiplexing and demultiplexing.**

**Multiplexing: (2Marks)**

- 1) Multiplexing is a process in which multiple data channels are combined into a single data or physical channel at the source.
- 2) Multiplexing divides the physical line (medium) into logical segments called as channels.
- 3) Multiplexing is a technique by which different analog and digital streams of transmission can be simultaneously processed over a shared link. Multiplexing divides the high capacity medium into low capacity logical medium which is then shared by different streams.
- 4) Multiplexing also known as MUX. The sending of multiple streams of information on a carrier at the same time is known as multiplexing.

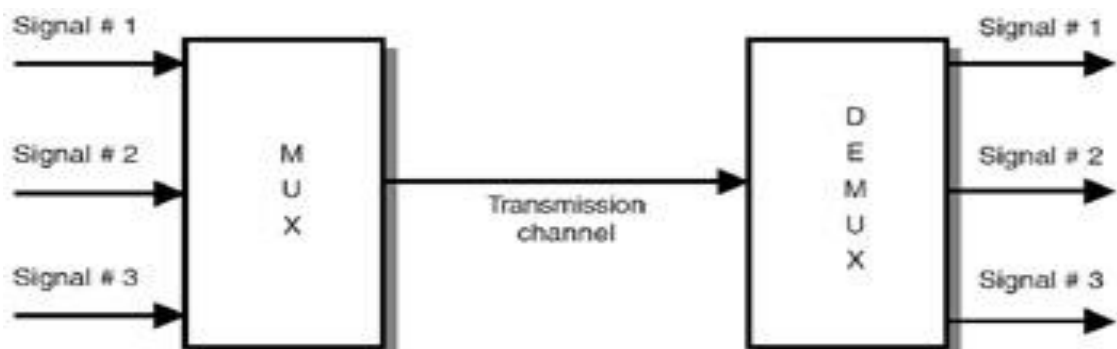

Categories of multiplexing:

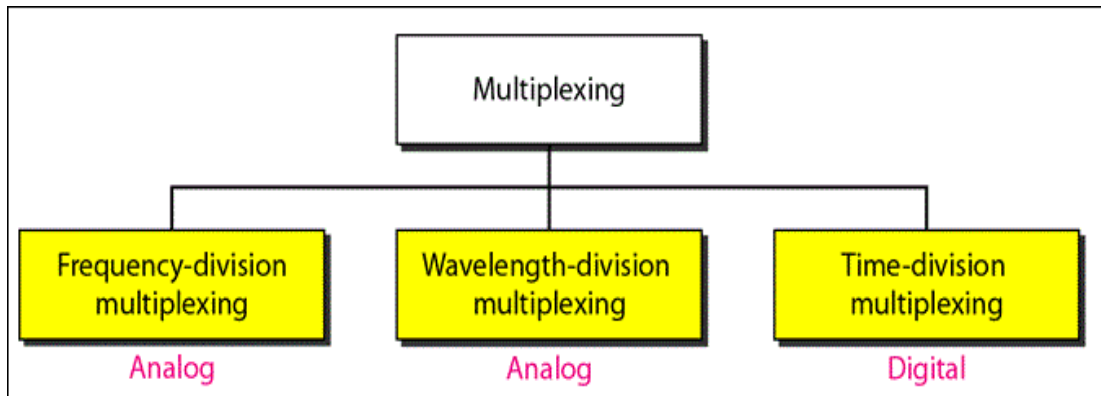

There are three basic multiplexing techniques: frequency-division multiplexing, wavelength-division multiplexing, and time-division multiplexing. The first two are technique designed for analog signals, the third, for digital signals.

**Demultiplexing: (2Marks)**

- 1) Demultiplexing is the process of separating multiplexed data channels at the receiver end.
- 2) Demultiplexing (DEMUX) is the reverse of the multiplex (MUX) process combining multiple unrelated analog or digital signal streams into one signal over a single shared medium, such as a single conductor of copper wire or fiber optic cable.
- 3) Thus, demultiplexing is reconverting a signal containing multiple analog or digital signals streams back into the original separate and unrelated signals.
- 4) In demultiplexing process use filters to decompose the multiplexed signal into its constituent signal. Then each signal is passed to an amplitude demodulation process to separate the carrier signal from the message signal. Then , the message signal is sent to the waiting receiver end.

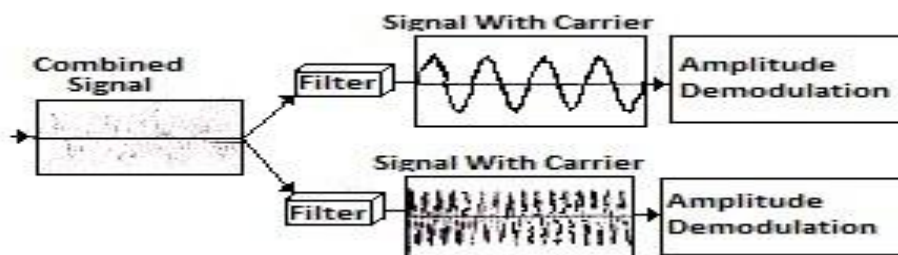

- d) For the following situations state which types of network architecture is appropriate?
- i. Number of user 100 or more.
  - ii. Data and resources need to be restricted.
  - iii. No network administrator required
  - iv. All users with equal priority.

(Each bit 1Mark)

- i) **Number of user 100 or more:** Client-server network is a network comprised of 100 or more workstations or client or users log into the server and gain access to their files.



Summer – 14 EXAMINATION  
Model Answer

Subject Code: 17430

Page 12/ 24

- ii) **Data and resources need to be restricted:** In Client-server network files are stores centrally, simplifying data backup and more secure. And it shared the resources to clients through server.
- iii) **No network administrator required:** peer-to-peer network is grouping of personal computers that all share information between each other. In this network each workstation or user is act as server as well as client or vice versa.
- iv) **All users with equal priority:** In peer-to-peer network, no administrator can control the privileges of each user so every workstation or users have equal priority in network.

e) **Explain DSL? List various types of DSL.(DSL explanation 2M, Types 2M)**

DSL- Digital Subscriber Line:

- 1) DSL provide much faster access to the internet through the telephone network.
- 2) DSL technology is one of the most promising for supporting high-speed digital communication over the existing local loops.
- 3) DSL uses high frequency bands for data separated by filtering.
- 4) The set is often referred to as xDSL , where x can be replaced by first letter of technologies (ADSL, VDSL, HDSL, SDSL).

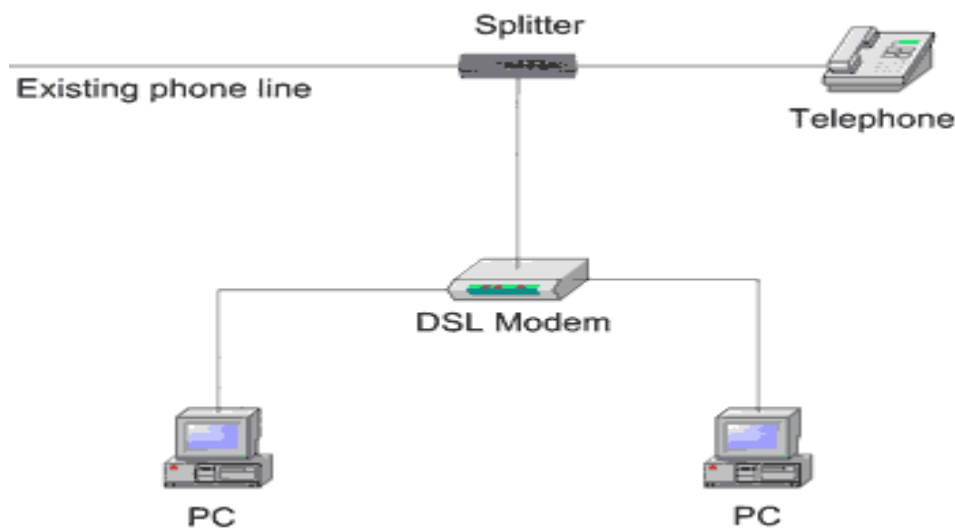

**Types of DSL:**

- 1) ADSL (Asymmetric Digital Subscriber Line)
- 2) ADSL Lite (Asymmetric Digital Subscriber Line)
- 3) VDSL (Very high-bit-rate Digital Subscriber Line)
- 4) HDSL (High-bit-rate Digital Subscriber Line)
- 5) SDSL (Symmetric Digital Subscriber Line)



Summer – 14 EXAMINATION  
Model Answer

Subject Code: 17430

Page 13/ 24

**f) Explain the function of ARP and RARP.(2 Functions of ARP 2M, 2 function of RARP 2M)**

**Functions of ARP (Address Resolution Protocol):**

- 1) The sender is a host and wants to send a packet to another host on the same network. The logical address that must be mapped to a physical address is the destination IP address in the datagram header.
- 2) The sender is a host and wants to send a packet to another host on another network. The host looks at its routing table and finds the IP address of the next hop for the destination. If it does not have routing table, it looks for the IP address of the default router. The IP address of the router becomes the logical address that must be mapped to a physical address.
- 3) The sender is a router that has received a datagram destined for a host on another network. It checks its routing table and finds the IP address of the next router. The IP address of the next router becomes the logical address that must be mapped to a physical address.
- 4) The sender is a router that has received a datagram destined for a host on the same network. The destination IP address of the datagram becomes the logical address that must be mapped to a physical address.

**Functions of RARP (Reverse Address Resolution Protocol ):**

- 1) Reverse address resolution protocol is a network protocol used to resolve a data link layer address to the corresponding network layer address.
- 2) It is the RARP which designed for diskless workstations that have no means of permanently storing their TCP/IP configuration information or TCP/ IP settings.
- 3) RARP does the opposite of ARP. While Arp broadcasts an IP address in an effort to discover its equivalent hardware address, RARP broadcasts the systems hardware address.
- 4) RARP server responds by transmitting the IP address assigned to that client computer. RARP can supply IP address to all the systems on a network segment.

- Q.4. Attempt any FOUR of the following:**  
**a) Draw format of IP datagram. (Diagram 4Marks)**  
**Format of IP datagram:**

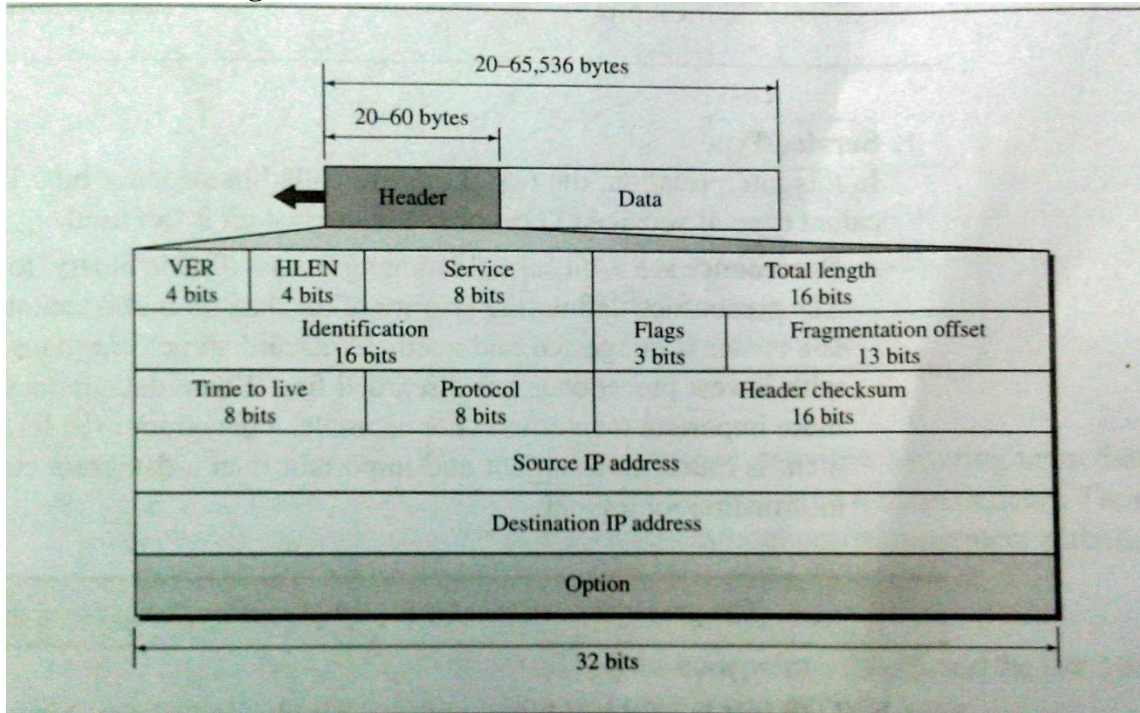

- b) Explain virtual network.(Diagram 1M, explanation 3M)**

**Virtual Network:**

- 1) A virtual network is a computer network that consists, at least in part, of virtual network links.
- 2) A virtual network link is a link that does not consist of a physical (wired or wireless) connection between two computing devices but is implemented using methods of network virtualization.
- 3) The two most common forms of network virtualization are protocol-based virtual networks
  - a. VLAN: Virtual LAN  
 Virtual LANs (VLANs) are logical local area networks (LANs) based on physical LANs. A VLAN can be created by partitioning a physical LAN into multiple logical LANs using a VLAN ID. Alternatively, several physical LANs can function as a single logical LAN. The partitioned network can be on a single router, or multiple VLAN's can be on multiple routers just as multiple physical LAN's would be. A VLAN can be on a VPN.
  - b. VPN: Virtual Private Network  
 A virtual private network (VPN) consists of multiple remote end-points joined by some sort of tunnel over another network, usually a third party network. Two such end points constitute a 'Point to Point Virtual Private Network'. Connecting more than two end points by putting in place a mesh of tunnels creates a 'Multipoint VPN'.

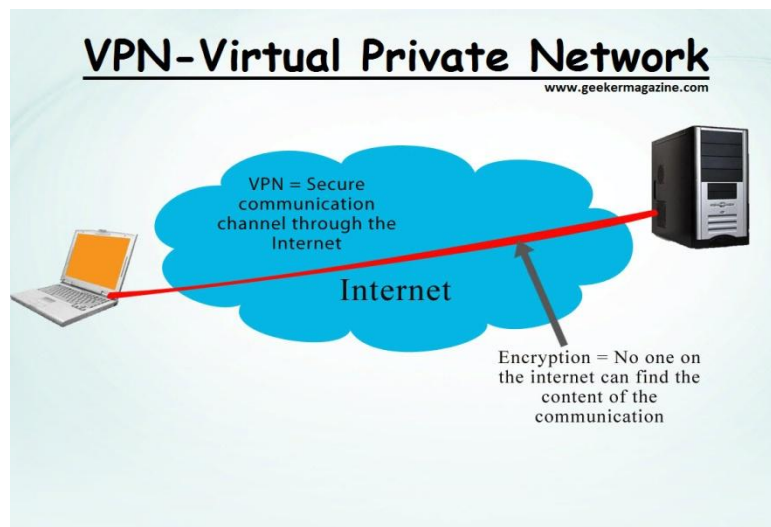

**c) What are the different methods of assigning a physical address to a computer? (Explanation 4 Marks)**

Physical Address:

- 1) Physical address is a local address. Its jurisdiction is a local network. It must be unique locally, but is not necessarily unique universally. It is called a Physical Address because it is usually implemented in hardware.
- 2) An example of a physical address is the 48-bit MAC address in the Ethernet protocol, which is imprinted on the NIC installed in the host or router.
- 3) A Host or a router requires two levels of addressing: logical and physical. Need to be able to map a logical address to its corresponding physical address and vice versa. These can be done by using either static or dynamic mapping.

**a. Static Mapping: (2 Marks)**

It involve in the creation of a table that associates a logical address with a physical address. This table is stored in each machine on the network. This has some limitations because physical address may changes in following ways:

- i) A machine could change its NIC, resulting in a new physical address.
- ii) In some LANs, the physical address changes every time the computer is turned on.
- iii) A mobile computer can move from one physical network to another, resulting in a change in its physical address.

**b. Dynamic Mapping: (2 Marks)**

In dynamic mapping each time a machine knows one of the two address (logical or physical), it can use a protocol to find the other one (ARP and RARP).

**d) Explain distributed Queue dual in MAN.( Explanation 2M, Diagram 2M)**

Distributed Queue dual bus in MAN:

- 1) Distributed Queue Dual Bus (DQDB) is a Data-link layer communication protocol for Metropolitan Area Networks (MANs), specified in the IEEE 802.6 standard and designed for use in MANs.
- 2) DQDB is designed for data as well as voice and video transmission and is based on cell switching technology (similar to ATM).

Summer – 14 EXAMINATION  
Model Answer

Subject Code: 17430

Page 16/ 24

- 3) The data rate fluctuates due to many hosts sharing a dual bus, as well as to the location of a single host in relation to the frame generator, but there are schemes to compensate for this problem making DQDB function reliably and fairly for all hosts.
- 4) The DQDB is composed of two bus lines with stations attached to both and a frame generator at the end of each bus.
- 5) The buses run in parallel in such a fashion as to allow the frames generated to travel across the stations in opposite directions. Below is a picture of the basic DQDB architecture.

**DQDB Architecture**

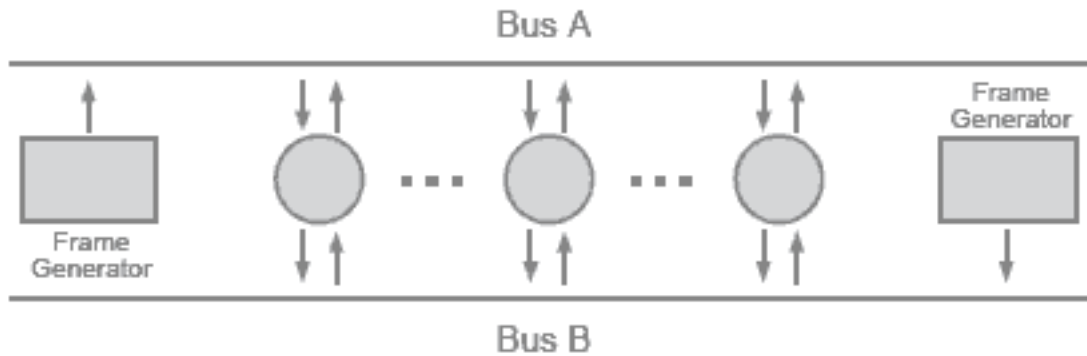

**DQDB network:**

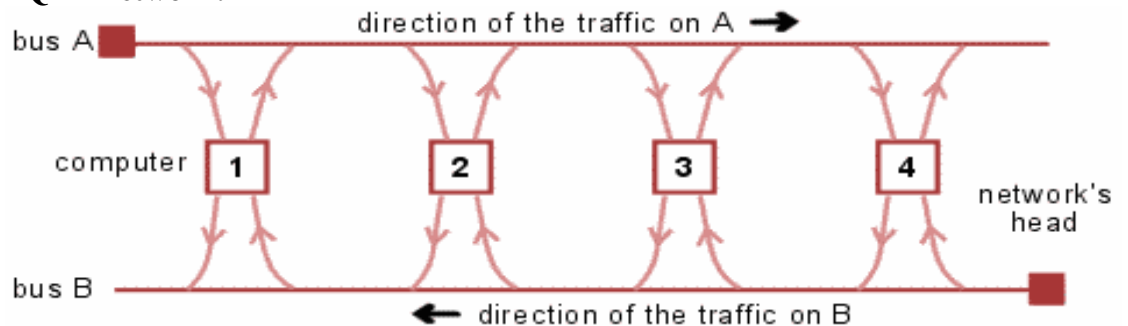





Summer – 14 EXAMINATION  
Model Answer

Subject Code: 17430

Page 17/ 24

e) Compare analog signal and digital signal. (any four points)  
(Total Marks=04, Appropriate any Four Compare = 04 Marks)

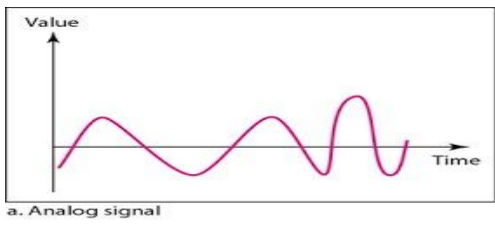
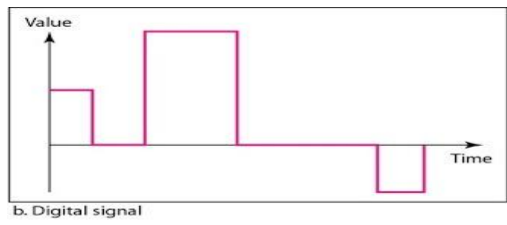
SR.NO	ANALOG SIGNAL	DIGITAL SIGNAL
1	An analog signal has infinitely many levels of intensity over a period of time.	A digital signal has only a limited number of values along its value.
2	As the wave moves from value A to value B. it passes through and includes an infinite number of values along its path.	Although each value can be any number, it is often as simple as 1 and 0.
3	 a. Analog signal	 b. Digital signal
4	Analog signals are higher density.	Digital signals are lower density.
5	Loss and Distortion is high.	Loss and Distortion is low.
6	Analog signals are less secure as compare with Digital signal.	Digital signals are more secure
7	Less bandwidth is require for transmission	High bandwidth is requiring for transmission.
8	Synchronization not present	Synchronization present.

f) Explain CRC with suitable example.( Explanation 2M Example 2 M)

Cyclic Redundancy Check (CRC):

A CRC code word of length  $l$  with  $n$ -bit data word is referred to as  $(l, n)$  cyclic code and contains  $(l-n)$  check bits.

These check bits are generated by module – 2 divisions. The dividend is the data word followed by  $r=l - n$  Zeroes and

The divisor is a special binary word of length  $r \times l$ . The CRC code word is formed by mod -2 addition of dividend and

The remainder.

Step by step procedure:

1. Append a string of  $r$  zeros to the data word where  $r$  is less than the number of bits pre decided divisor by 1 bit i.e. if divisor = 5 bits then  $r = 4$  zeros.
2. Divide the newly generated data unit in step 1 by the divisor . It is binary division
3. The remainder obtained after division is the  $r$  bit CRC.
4. This CRC will replace the  $r$  zeros appended to the data unit to get the codeword to be transmitted.

**Example:**

**Division in CRC encoder:**

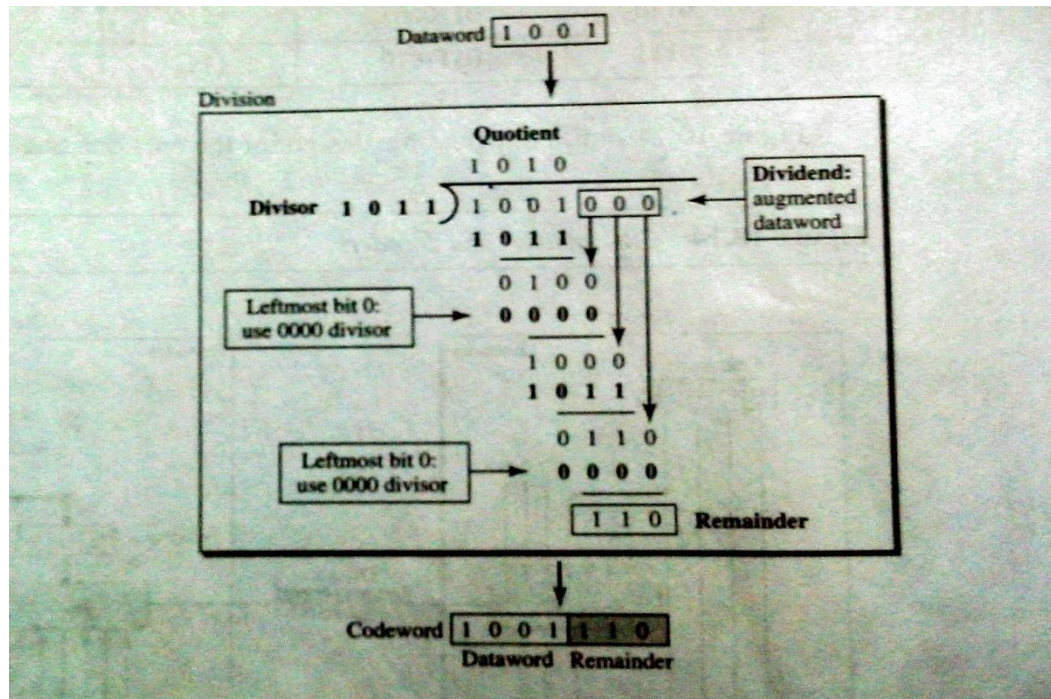

**Q.5. Attempt any FOUR of the following:**

**a) Explain synchronous TDM. (2 marks explanation, 2 marks diagram)**

It is a technique in which several connections share a single large bandwidth link.

In synchronous TDM the data of each sender is divided into equal-sized units (likewise bit, character, etc.). If there are  $n$  senders, then the total time frame of the link is divided into equal-sized  $n$  time slots, and each slot is allocated to send data of users sequentially.

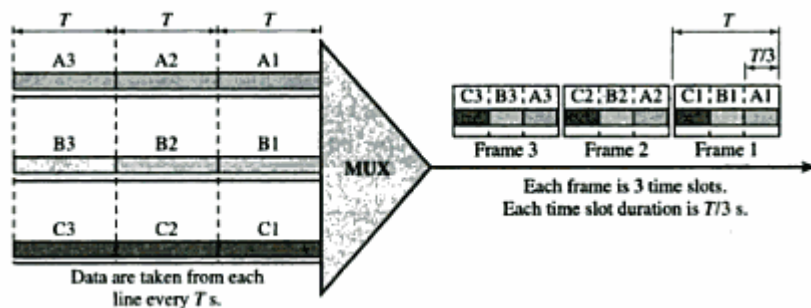

As shown in the figure, there are three sender connections, hence the time frame is divided into three time slots, and each slot of the frame is allocated to each sender sequentially. If a particular sender is not having any data to send, then that time slot is wasted.

Data rate of output link must be  $n$  times the data rate of connection.

**b) Explain satellite communication. (2 marks explanation)**

Satellite communication is similar to terrestrial microwave communication, except that the satellite acts as one of the stations. The satellite performs the functions of an antenna and the repeater together. Ground station A sends information to ground station B via the satellite.

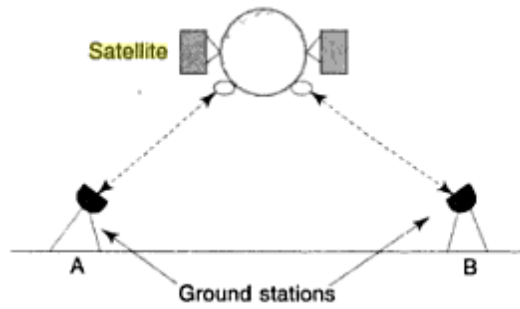

(2marks diagram)

Two frequency bands are used for signals from earth to satellite (uplink) and from satellite to earth (down link)

Satellite takes uplink signal coming from sender process it & converts to downlink frequency & transmits it towards earth .the coverage area over which the signal of satellite is available is called as footprint of satellite

There are 3 methods for satellite communication system:

- 1) FDMA(frequency division multiple access)
- 2) TDMA (time division multiple access)
- 3) CDMA(code division multiple access)

FDMA puts transmission on separate frequency TDMA assigns each transmission a certain portion of time On the designated frequency CDMA gives unique code to each transmission and spreads on available set of frequencies Multiple access indicates that many users can use

c) State the names of layer that perform the following functions:

- i. Data encryption
  - ii. Error correction
  - iii. File transfer
  - iv. Data encoding.
- (1mark per correct layer)

- i) Data encryption :- Presentation layer
- ii) Error correction:- transport layer
- iii) File transfer:- application layer
- iv) Data encoding:- Physical layer

d) Explain working principle of bridges. (2 marks explanation, 2mark diagram)

Bridge is connecting device which works on layer 2of OSI model i.e. it will work on physical layer & data link layer of OSI.

Each incoming packet will pass to MAC layer of bridge here Physical address of destination is checked if it is destined to another subnet then it is forwarded to that subnet but if that subnet is of different type then LLC will remove header and apply new header .

To identify destination present on which subnet bridge maintains forwarding table containing information about on which port data to be handed over for which destination .

Summer – 14 EXAMINATION  
Model Answer

Destination physical address	Port
A1	10
A2	20

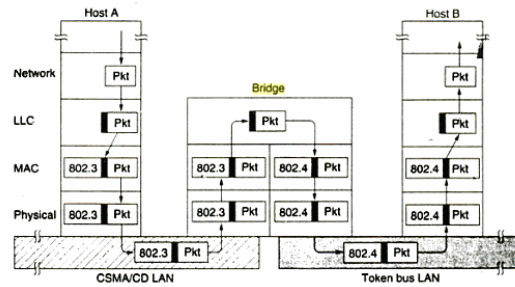

bridge connecting 802.3 & 802.4

By analyzing source address of incoming Packet Bridge upgrades its forwarding table by learning about which device present on which subnet.

Bridge does not change physical address. If bridge is having different LAN on segment then bridge will have separate MAC & LLC layer per type of LAN.

**e) Explain persistent TCP connection. (3marks explanation)**

In non persistent connection as soon as server completes its response it ends connection but in case of persistent connection the server keeps open connection for next data.

The sever closes connection at request of client or after occurrence of time out condition .Persistent connection is used for sending receiving multiple request and response using single connection

(1 mark diagram)

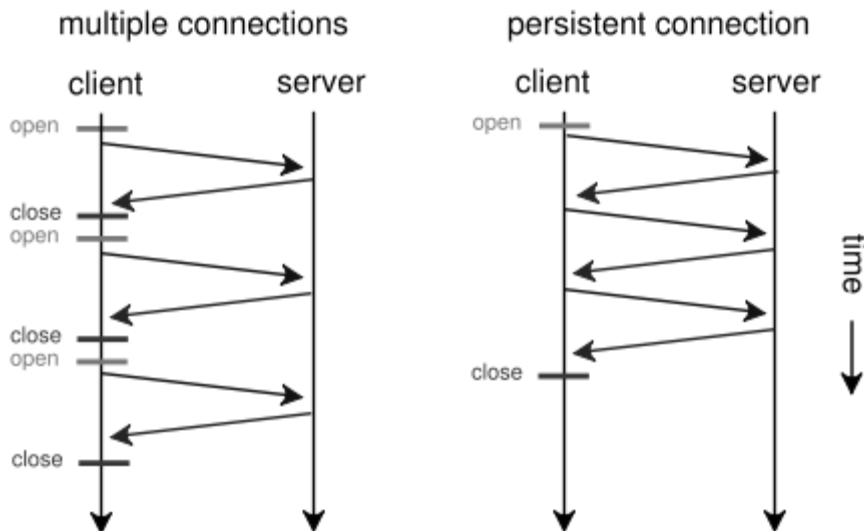

As shown in figure in non persistent connection if sender wants to send data multiple times then each time new connection establishment are required. But in persistent connection single connection is used for sending multiple data

**f) Explain need of standard organizations. List any two standard organizations. Need for standard (2marks)**

- Standards are essential in creating and maintaining an open and competitive market for equipment Manufacturers and in guaranteeing national and international interoperability of data and telecommunication technology and processes.



Summer – 14 EXAMINATION  
Model Answer

Subject Code: 17430

Page 21/ 24

- 2) They provide guidelines to manufacturers, Vendors, govt. agencies and other service providers to ensure the kind of interconnectivity necessary in today's market place and in international communication.

**Standard organizations (any two organization 1mark per organization)**

- i) International standard organization (ISO)
- ii) American National Standard institute (ANSI)
- iii) Institute of electrical & electronics engineers (IEEE)

**Q.6. Attempt any Four of the following:**

**a) Define the following terms:**

- i. **Amplitude**
- ii. **Bandwidth of signal**
- iii. **Phase**
- iv. **Frequency.**

**(1mark per point)**

- i. **Amplitude:-**It is defined as voltage level of signal maximum voltage level is called as maximum amplitude.
- ii. **Bandwidth of signal:-** It is difference between highest & lowest frequencies contained in information. Bandwidth of channel is is difference between highest & lowest frequency supported by that channel.
- iii. **Phase:-**It describes position of waveform with respect time (t=0).
- iv. **Frequency:-** It is defined as no. of cycles completed by signal per second.

**b) Explain the following :**

- i) **WAN Addressing**
- ii) **Internet topology**

**(2marks per description )**

**WAN Addressing:** -WAN addressing is hierarchical addressing system .The address of a host on WAN is composed of two parts as follow

1. Switch no:-It identifies switch to which host is connected
2. Host no.:- It identifies Host which is attached to that host

Overall address is made up of combination of switch no. & host no. as shown in following fig

Switch no	,	Host no.
-----------	---	----------

10	,	20
----	---	----

Following figure shows hierarchical addressing scheme on portion of WAN, consisting of 2 switches each having 2 host connected

Host have unique no specific to switch to which it connected

**Internet topology:-**

It is representation of of interconnection of between directly connected peers or nodes in network .It describes how host routers etc connects to each other

It is organized in hierarchical manner as shown in figure .At very top high speed backbone operated by MCI &at bottom end users are present.

Summer – 14 EXAMINATION  
Model Answer

Subject Code: 17430

Page 22/ 24

There are intermediate layers of network access providers (NAP) & Internet service providers (ISP).ISP is connected to end user & it is responsible for passing call to NAP.

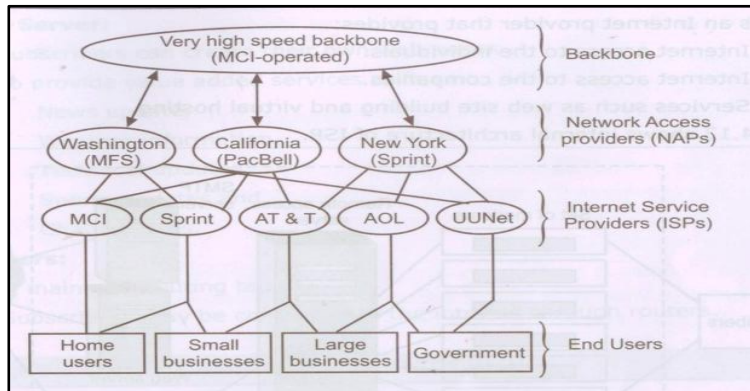

c) Describe functioning of application layer in TCP/IP Protocol Suite (2marks Deception 2 marks diagram )

Application Layer enables user (either human or application) to access network. It provides user interfaces support for services such as electronic mail, file transfer .It is combination of sessions application, sessions layer, presentation layer of OSI model & their functionalities likewise dialog control, encryption, and compression etc

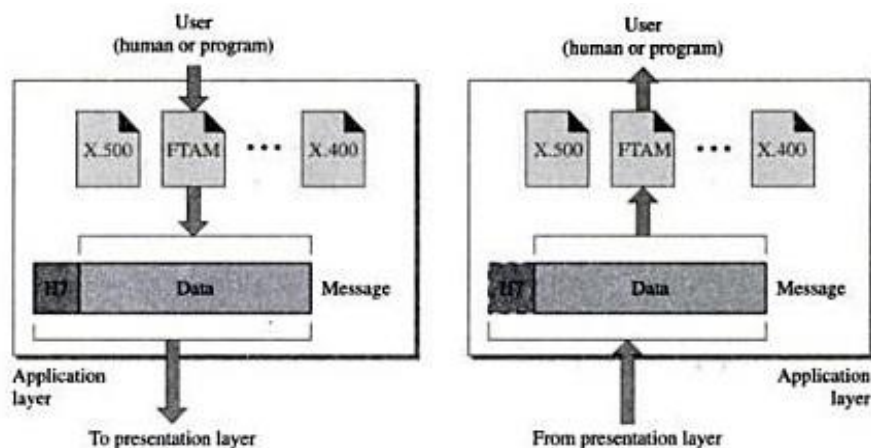

Summer – 14 EXAMINATION  
Model Answer

Subject Code: 17430

Page 23/ 24

**d) Explain dial up access & leased lines ( 2marks dial up ,2marks leased line)**

**Dial up access:** - It is internet (remote) access methodology .It uses PSTN to connect to ISP. The user's computer or router uses an attached modem to encode and decode Internet Protocol packets and control information into and from analogue audio frequency signals, respectively. This technology does not requires large infrastructure  
The dial up access data link layer protocols likewise PPP, SLIP.

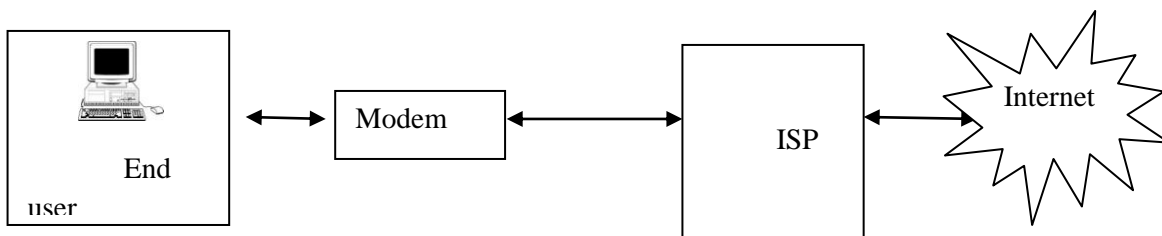

**Leased Line:** - It is internet access methodology which uses permanent dedicated high speed link

Direct dedicated line runs from end user to service provider likewise ISP .It is dedicated point to point copper or OFC connection between end user & ISP

Generally leased line is provided with fix IP address.

Leased lines are expensive but provides high bandwidth, high availability

Leased lines are generally used by users who requires high traffic & high availability likewise site to site connectivity

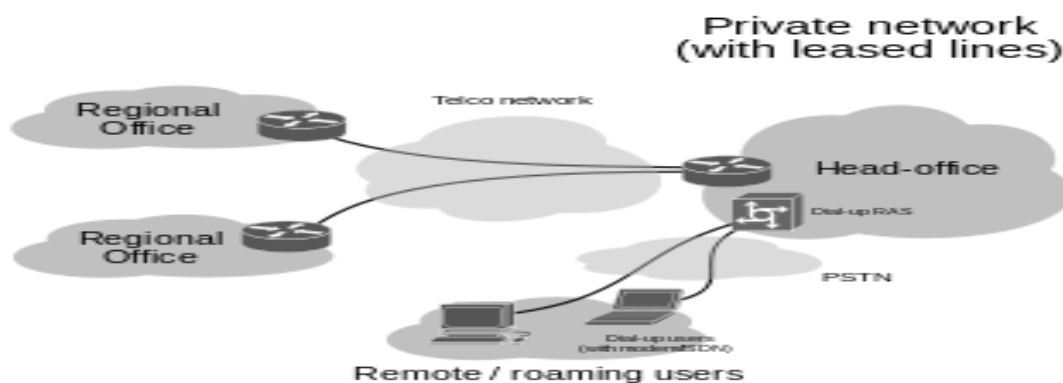

**e) Give any four point of comparison between TCP & UDP( 1mark per correct point )**

TCP	UDP
1) TCP is Transport layer protocol & use in TCP/IP Protocol suite.	1) UDP is Transport layer protocol & use in TCP/IP Protocol suite.
2) Connection oriented.	2) Connection less.
3) More reliable.	3) Less reliable.
4) Speed is less.	4) Speed is more.
5) Complexity is more.	5) Complexity is less.
6) Performs more functions.	6) Performs less function.
7) Provides flow control.	7) Doesn't provide flow control.
8) More overhead (because of ACKs).	8) Less overhead.
9) More powerful.	9) Less powerful.



**f) Describe in brief Virtual Network**

**(2 marks description, 2 marks diagram)**

Virtual network is network which creates illusion of computers present on different physical network to be on same network

Virtual network connects computers present on different network seamlessly without knowing to user about any kind of traffic handover & addressing.

In this type of network there is no direct physical link between to networked computers but are connected by means of routers & internet

Internet is a virtual network connecting no. of networks together

