



**MAHARASHTRA STATE BOARD OF TECHNICAL EDUCATION**

**(Autonomous)**

**(ISO/IEC-270001 – 2005 certified)**

**WINTER-2014 EXAMINATION**

**Subject code: 17309**

**Model Answer**

**Page No: 1/15**

**Important Instructions to examiners:**

- 1) The answer should be examined by keywords and not as word-to-word as given in the model answer scheme.
- 2) The model answer and the answer written by candidate may vary but the examiner may try to assess the understanding level of the candidate.
- 3) The language error such as grammatical, spelling errors should not be given more importance. (Not applicable for subject English and communication skill).
- 4) While assessing figures, examiner may give credit for principal components indicated in the figure. The figure drawn by candidate and model answer may vary. The examiner may give credit for any equivalent figure drawn.
- 5) Credits may be given step wise for numerical problems. In the some cases, the assumed constants values may vary and there may be some difference in the candidates answer and model answer.
- 6) In case of some questions credit may be given by judgment on part of examiner of relevant answer based on candidates understanding.

Q.1A) Attempt <b>any three</b> of the following:	<b>12</b>
i) Draw Conventional signs for : a) Ground level      b) Brick work c) Wood work          e) Concrete	

Ans:- a) **Ground level :-**

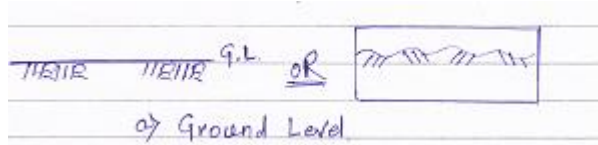

b) **Brick work :-**



c) **Wood work :-**

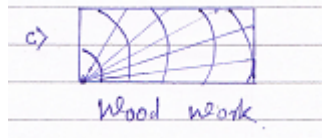

e) **Concrete:-**



(\*Note-1marks for each symbols)

ii)What do you mean by Roominess? Explain With Sketch .

Ans:- **Roominess:-** This principle of planning is related with dimension of the room i.e length width and height .Rooms must be functional with possible dimensions a length to width ratio should be 1.2 to 1.5 .A room having width larger than 1.5 times its width will give tunnel effect and thus should be avoided .

Case-I)

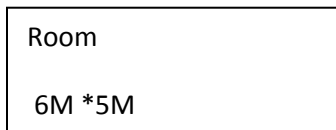

$$l/b = 6/5 = 1.2 < 1.50$$

Room is having good Roominess  
And hence no tunnel effect

Case-II)

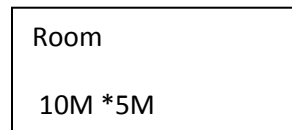

$$l/b = 10/5 = 2 > 1.50$$

Hence Room is having tunnel effect

2  
marks

2  
marks

iii) Draw symbols for :

- a) Kitchen Platform                      b) Sink  
c) Bed                                      d) Wardrobe.

Ans:- a) Kitchen Platform :-

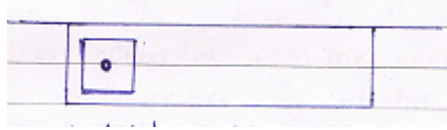

b) Sink :-

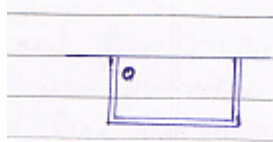

c) Bed :-

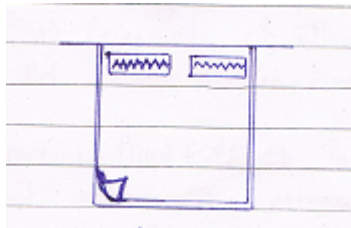

d) Wardrobe:-

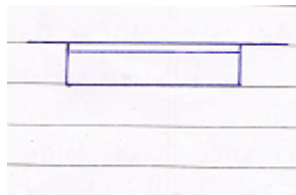





(\*Note-1marks for each symbols)

iv) Draw Following Lines :

- a) Extension line                      b) Dimension line  
c) Hidden line                      d) Section line

Ans:-

a) Extension line	
	Thin (0.2 to 0.3mm)
b) Dimension line	
	Thin (0.2 to 0.30mm)
c) Hidden line	
	Medium (0.35 to 0.50mm)
d) Section line	
	Thick (0.6 to 1.00mm)

(\*Note-1marks for each Line )

b) Draw a plan scale 1:50 for a proposed single storied bank building .Built up area is limited to 200 M<sup>2</sup>

8

Ans:-

\*

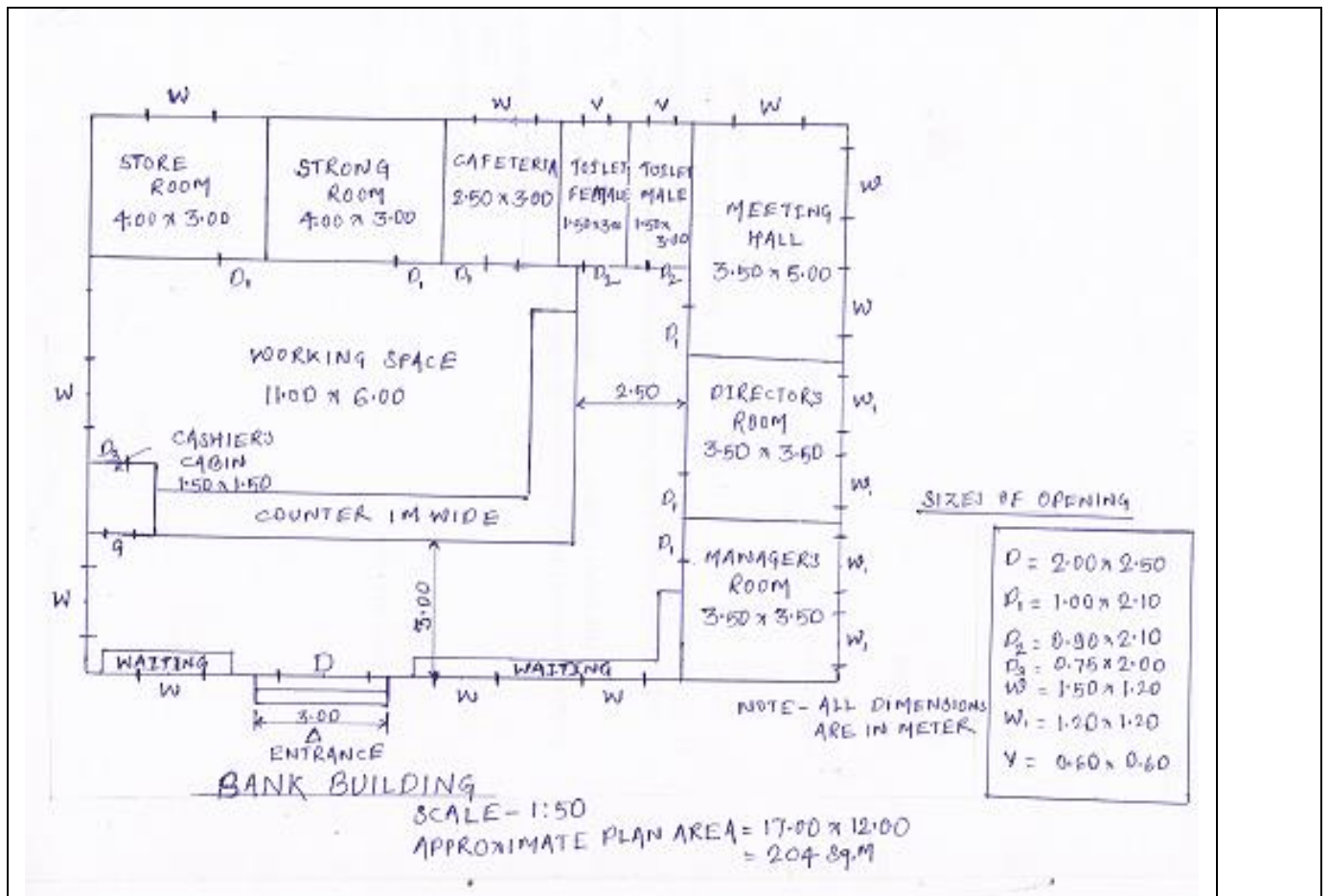

(\*Note for neat and suitable line plan with scale 1:50 -4 marks, for door and window position -2 marks and 2 marks for labeling )

Q.2 figure 1 shows line plan of residential building. Draw to a scale of 1:50 the following views:

- Developed plan
- Front elevation .
- Section along PQ.

Use following construction notes:

- depth of foundation 1.2 M below G.L.
- Plinth height above G.L. 750 MM.
- Floor to slab bottom height of all rooms is 3100MM and that for W.C and that for W.C and bath is 2400 MM.
- Wall thickness in super structure is 300 MM for external walls and 200MM for internal walls.
- Slab thickness 120 MM.

12

08

08

f) Chajja projection 600MM.

g) Assume any other suitable data, if required.

Ans:- i) Developed plan:-

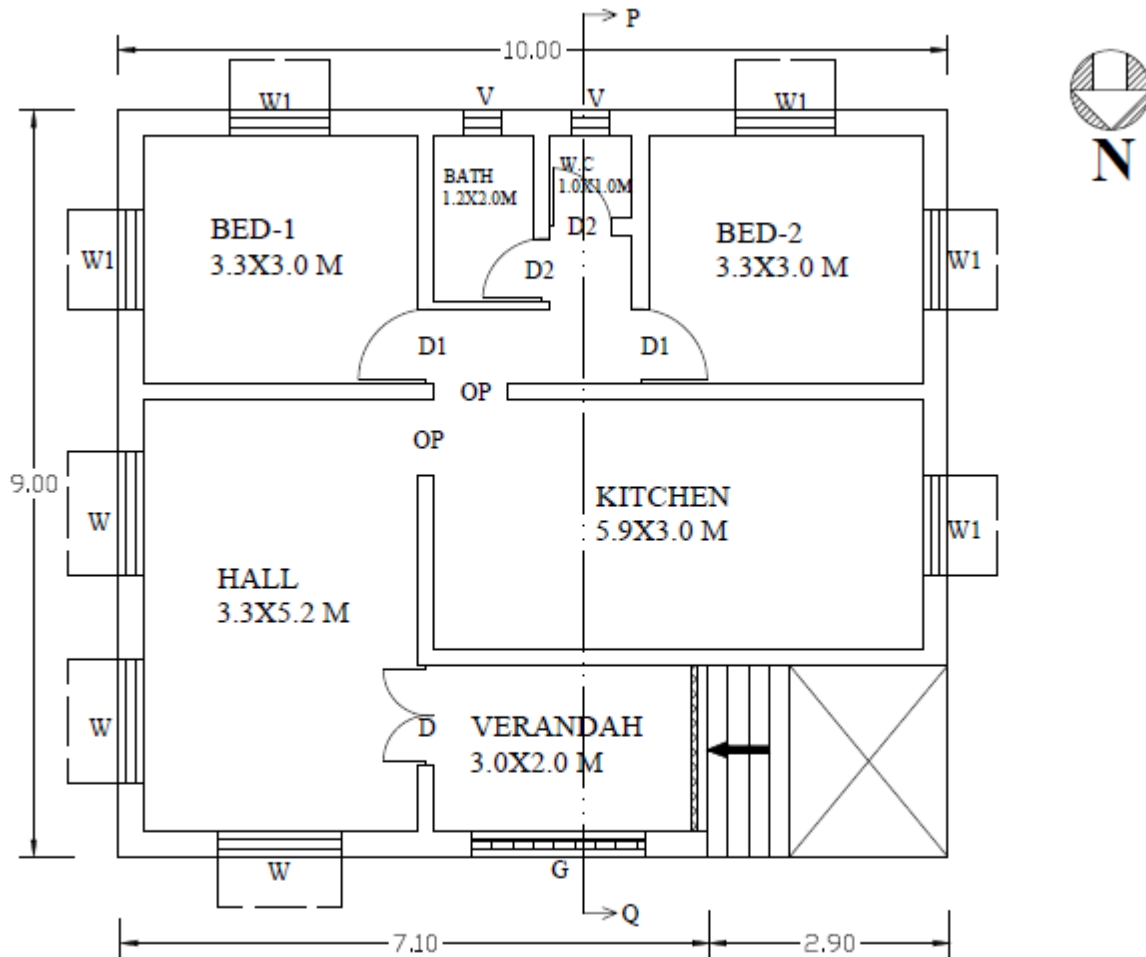

**DEVELOPED PLAN (SCALE- 1:50)**

(\*Note-developed plan 4 marks, labeling-2marks, dimensions 2 marks, doors and windows 3marks neatness 1 marks)

\*

ii) Front elevation

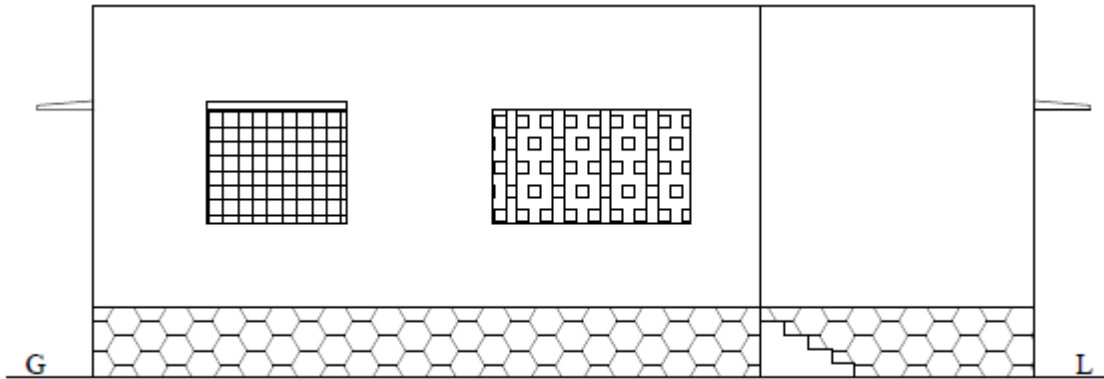

**ELEVATION** (SCALE -1:50)

(\*Note :-Correct elevation 6 marks, neatness 2 marks)

iii) Section along PQ.

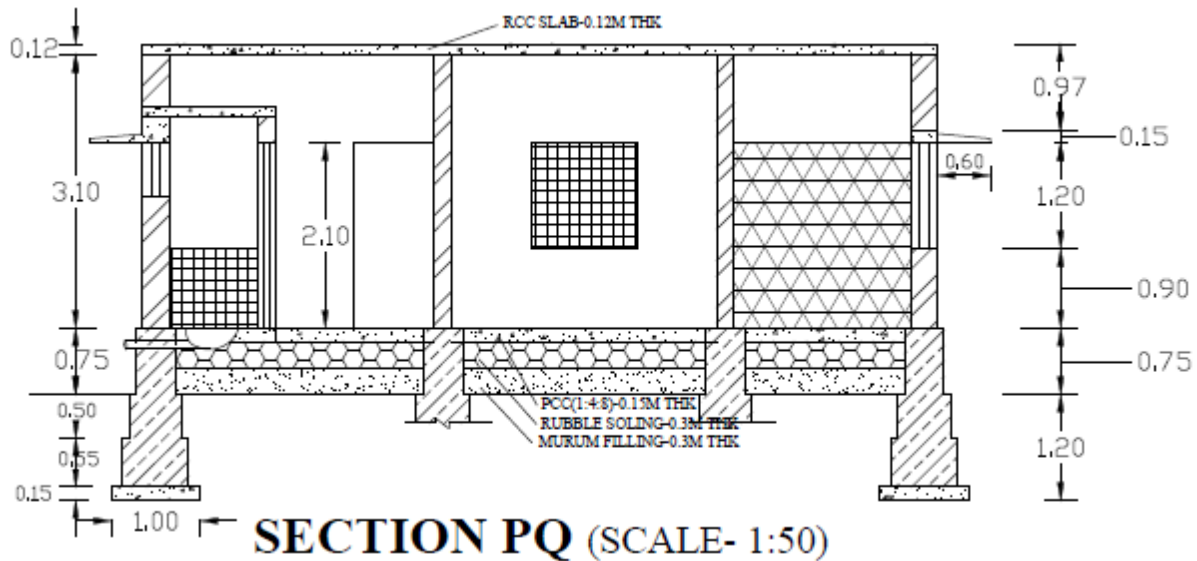

(\*Note –Correct section 4 marks ,all dimension 2 marks, material symbol 2marks)

Q.3 Answer any three :

24

a) Draw a suitable scale site plan for the building mentioned in Question No.2 (Fig No.1) .The plot size is 15 M\* 20 M .The road is on north side of the plot parallel to 15M Side

Ans:-

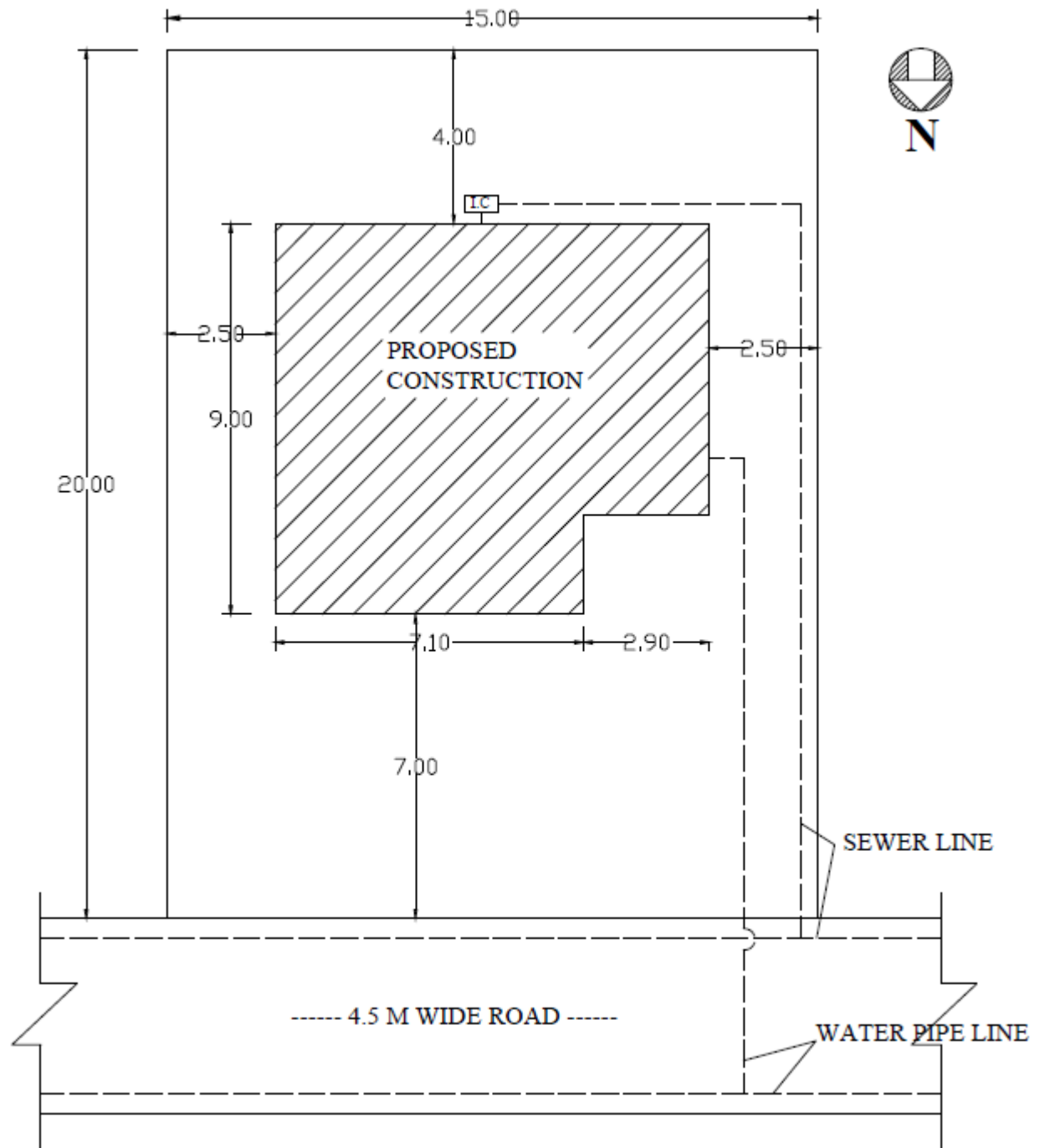

**SITE PLAN** (SCALE- 1:200)

(\*Note-Correct site plan 4 marks ,site margins 2 marks, Water and sewer line 1marks,neatness 1 marks )



b) if FSI Permission for the plan in question No.2 is 1.2;calculate :

i)FSI consumed

ii)Built up area

iii)Carpet area

iv)FSI remaining.

**Ans:- i)FSI consumed =(Built up area/Plot area )=(83.33 / 300)= 0.28**

**ii)Built up area :- 83.33 Sq.M**

**iii)Carpet area :** Hall=  $3.2*5.2=17.16$

Bed 1 = $3.3*3=9.90$

Bed 2= $3.3*3=9.90$

**Total = 17.16+9.90+9.90=36.96Sq.M**

**iv)FSI remaining.:-** Permissible FSI =1.2 as given.

FSI remaining= $1.2-0.28=0.92$

(\*Note 2 marks for each area )

\*

d) State various units required for primary health center.

**Ans:Various unit required for primary health center are as follows :-**

- 1)Entrance and Waitting
- 2)Reception and office
- 3)Doctors Room
- 4)Examination room
- 5)Dressing Room
- 6)Medicine Room
- 7) Nurse Room
- 8)Operation Theatre
- 8) General ward male
- 9) General ward female
- 10)Store Room

<p>11) Toilet Block For Male 12) Toilet Block For Female</p> <p style="text-align: center;"><i>(*Note -8 marks for any eight units above )</i></p>	
<p>e) Describe the principle used in perspective drawing. What do you mean by vanishing point and eye level in perspective drawing? What is the difference between one point perspective and two point perspectives?</p>	
<p><b>Ans: Principles used in perspective drawing :-</b></p> <ol style="list-style-type: none"> <li>1) The lines appear to be shorter than their actual length and their effect increases as the distance of the object increases.</li> <li>2) The picture of all points and lines on the picture plane coincides with the points and lines themselves.</li> <li>3) Perspective of all parallel lines which are not parallel to the picture plane, converge to a point. (Vanishing point)</li> <li>4) Perspective of all parallel lines which are also parallel to the picture plane are themselves parallel.</li> </ol> <p><b>Vanishing point:-</b> The vanishing point on a line is the point where the perspective of all straight lines except those parallel to the picture plane appears to terminate. This is denoted by V or VP.</p> <p><b>Eye level/Horizontal Plane or Horizon:-</b></p> <p>Eye level is the height of the eye of the observer at a station point from where the observer is viewing the object and the imaginary plane at the level of eye at the station point is called the horizontal plane.</p> <p><b>Difference between One point Perspective and Two point Perspective :</b></p> <p>In one point Perspective the two sides of an object are parallel to the picture plane and the remaining sides are perpendicular to the picture plane.</p> <p>In two point Perspective the two sides of an object are inclined to the picture plane then there are two vanishing points for two sets of horizontal lines. This is the difference between One point Perspective and Two point Perspective.</p> <p><i>(*Note –any two Principles -2 marks ,definition Vanishing point 2 marks, Eye level 2 marks and difference 2 marks)</i></p>	*

Q.4 Answer any two	16
<p>a) What do you mean by orientation of a building?</p> <p>‘it is very difficult to get a proper orientation for all flats in a Apartment ‘</p> <p>Comment on this Statement.</p>	
<p><b>Ans:- Orientation of a building:-</b> Orientation is the method of proper placement of planned unit of the building in relation to natural elements like sun,rain,wind outlook ,topography etc. The position of building is decided with respect to “North “ to placed the different units of room to achieve natural ventilation ,air circulation and Lighting. or Orientation is necessary to achieve maximum advantage from natural elements.</p> <p>It is difficult to get proper Orientation for all flats in a apartment because apartment consist of no of floors and about two to four flats or even more flats at one floor which is located at different direction of a building and hence that particular flats get the benefits of that particular direction .for e.g a flat which is located to east will get more sunlight but less ventilation .Where as a flat which is located towards west will get more natural wind and ventilation but will not receive morning sunlight rays and hence proper Orientation is not possible .for all flat in a apartment .</p> <p style="text-align: center;"><i>(*Note- Orientation definition -4 marks ,Explanation -4 marks )</i></p>	*
<p>b)Draw a detailed plan and section for a RCC footing from following data for a stepped footing</p> <p>.</p> <p>1)Size of column 230MM diameter</p> <p>2)Frist step 1000MM *1000MM*300MM(thk)</p> <p>3)Second step 800MM*800MM *200MM</p> <p>4) Depth of footing below G.L is 1000 MM</p> <p>5)Size of excavation is 1200MM *1200MM.</p>	
<p><b>Ans:-</b></p>	

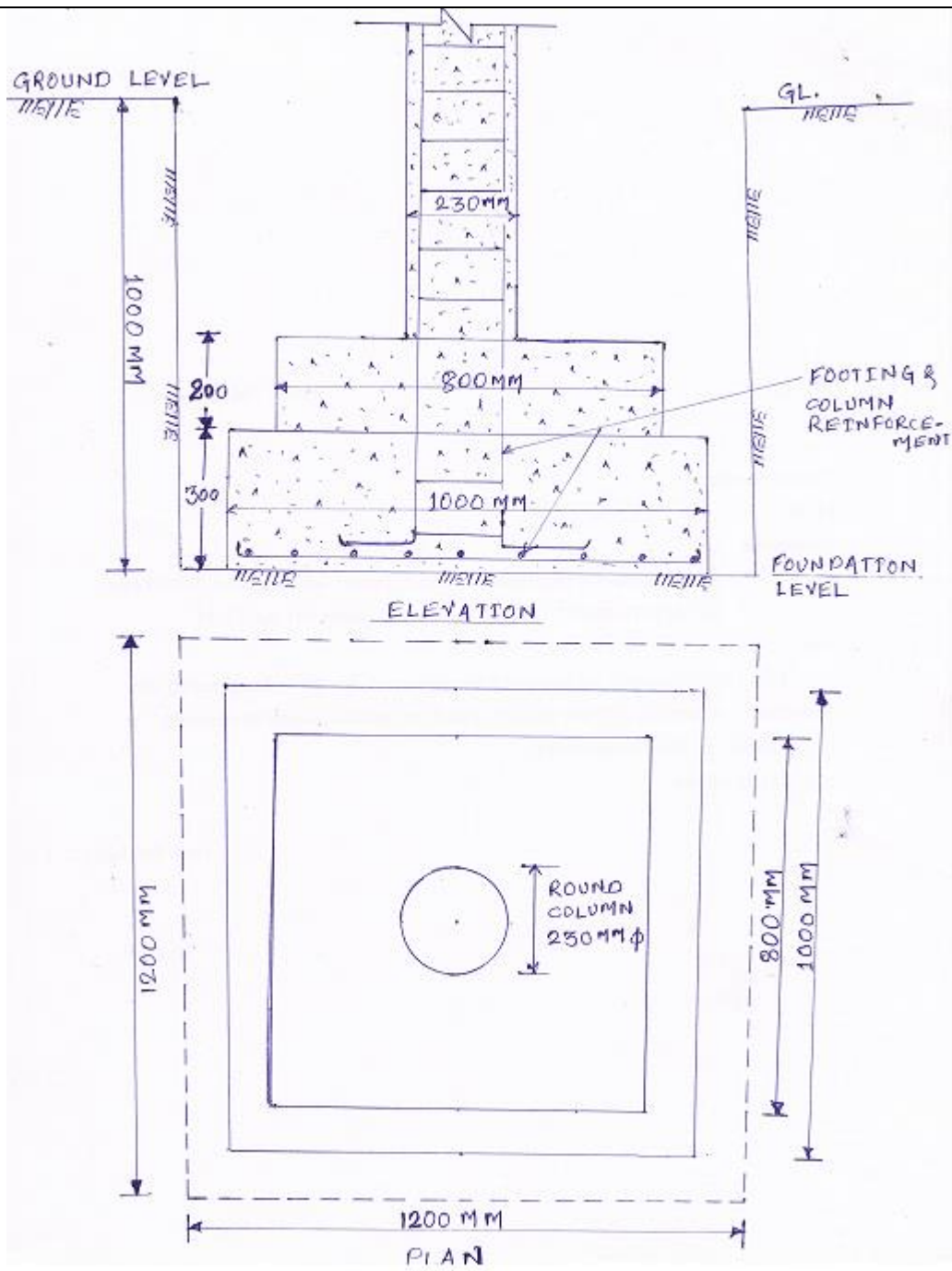

(\*Note-for neat and suitable plan -3 marks with scale 1:10 or suitable Section -3 marks ,dimensioning and labeling-2 marks)

c) Why construction note is written on a submission drawing? Write construction notes for a residential building in Question No.2 (Fig No.1)

**Ans:-Necessity of written construction notes on a submission drawing:-**

While constructing and getting approval for construction of any building we required to draw submission and detailed drawing for that building, in both the drawing it is not possible to show every details on drawing and hence the things for which we are not able to draw are written in wording form under the heading construction notes on the drawings for e.g type of structure, types of materials and its make etc.

**Construction notes for a residential building in Question No.2 (Fig No.1):**

- 1) Type of structure – Load bearing structure .
- 2) Depth of foundation -1.2 m below ground level .
- 3) Plinth height -750mm above average ground level .
- 4) U.C.R. masonry in plinth and foundation in cm (lib)
- 5) B.B. . masonry in C.M lib in superstructure .
- 6) Roofing is R.C.C slab 120mm in R.C.C (1:1/2:3) at a ceiling height of 3.00m.
- 7) Finishing:- External plastering sand face in C.M 1:4. & Internal plastering with neeru finish in C.M 1:4..
- 8) Flooring :-Spartex tiles in various rooms on bed concrete P.C.C (1:4:8) of 150 mm thk.

(\*Note-Necessity of construction -4 marks and for each construction notes 1/2 marks)

Q.5 a) See Fig.2 and draw to a scale perspective drawing .Assume eye level 1.4M above ground level .The station point is 3M from picture plane.\

OR

b) Draw to the scale two point perspective drawing of steps shown in Fig.3 .assume eye level 1.4 M above G.L and station point 3M from picture plan

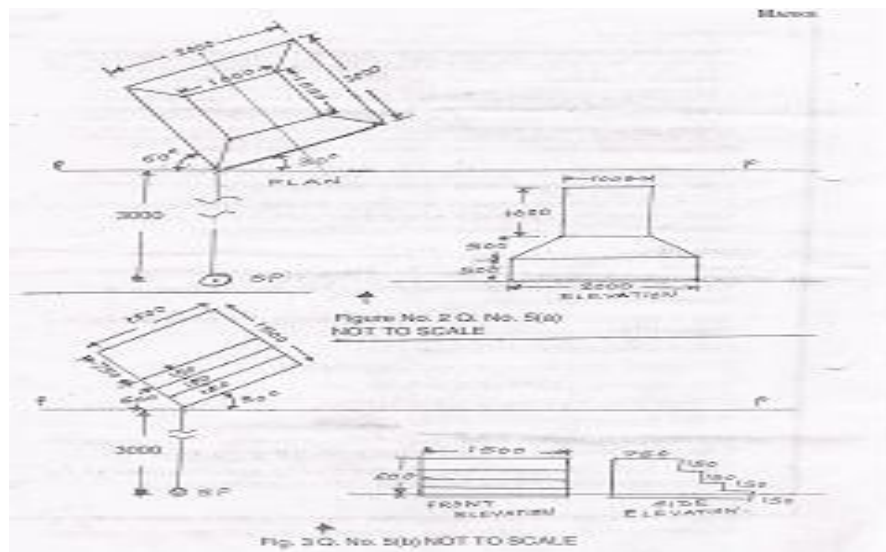

12

Ans Q.5 a)

:-

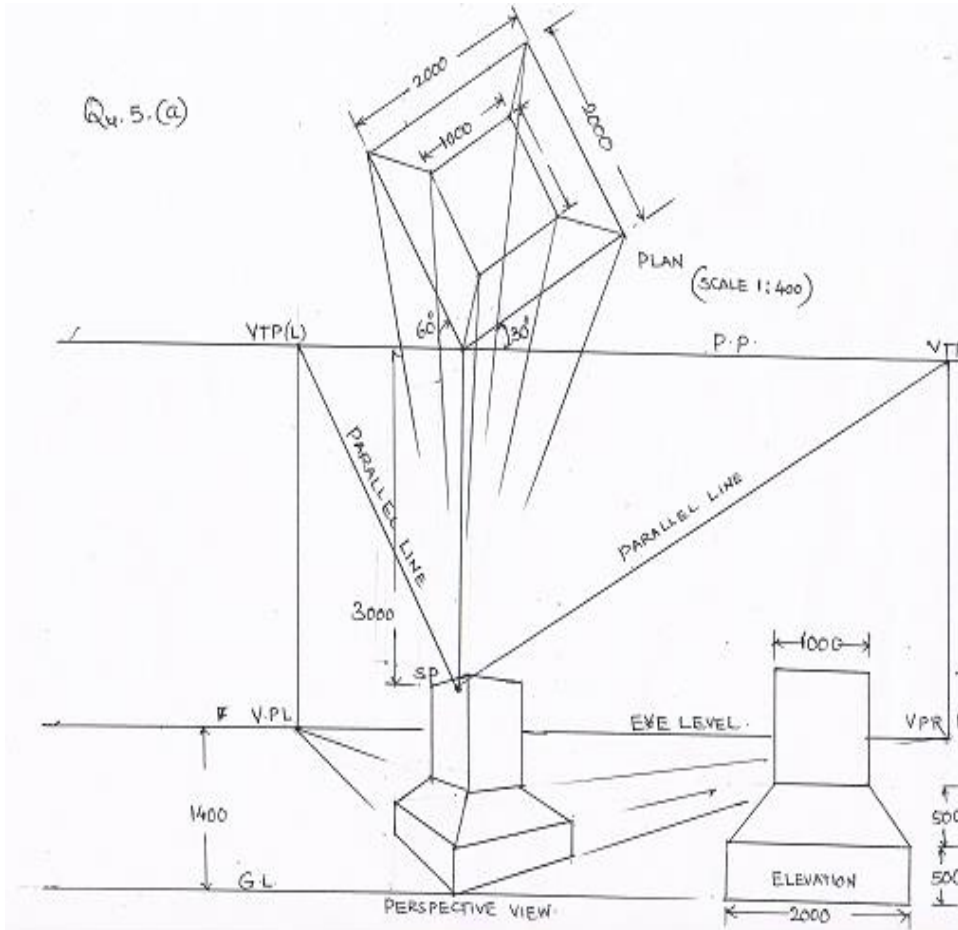

(\*Note -2 marks for plan, 1 mark for elevation, construction lines 2 marks ,eye level 1 marks, station point 1 marks and correct object 5 marks)

OR

b) Draw to the scale two point perspective drawing of steps shown in Fig.3 .assume eye level 1.4 M above G.L and station point 3M from picture plan

17309

Ans:- Q.5 b)

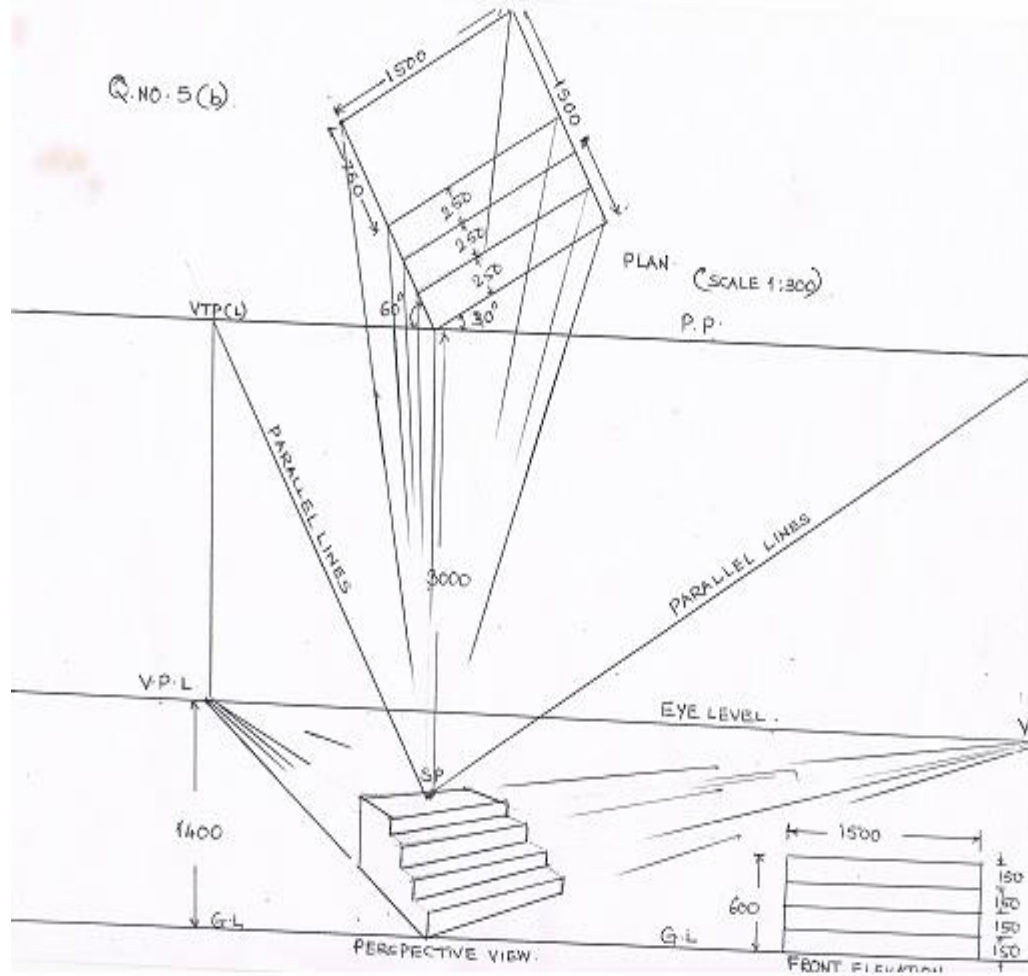

(\*Note -2 marks for plan, 1 mark for elevation, construction lines 2 marks ,eye level 1 marks, station point 1 marks and correct object 5 marks)