



WINTER – 19 EXAMINATION

Subject Name: Microcontroller & Application

Model Answer

Subject Code: 22426

Important Instructions to examiners:

- 1) The answers should be examined by key words and not as word-to-word as given in the model answer scheme.
- 2) The model answer and the answer written by candidate may vary but the examiner may try to assess the understanding level of the candidate.
- 3) The language errors such as grammatical, spelling errors should not be given more importance (Not applicable for subject English and Communication Skills).
- 4) While assessing figures, examiner may give credit for principal components indicated in the figure. The figures drawn by candidate and model answer may vary. The examiner may give credit for any equivalent figure drawn.
- 5) Credits may be given step wise for numerical problems. In some cases, the assumed constant values may vary and there may be some difference in the candidate's answers and model answer.
- 6) In case of some questions credit may be given by judgement on part of examiner of relevant answer based on candidate's understanding.
- 7) For programming language papers, credit may be given to any other program based on equivalent concept.

Q. No.	Sub Q. N.	Answer	Marking Scheme															
Q.1		Attempt any FIVE of the following:	10M															
	a)	Compare address bus and data bus used in 8051.	2M															
	Ans:	<table border="1"> <thead> <tr> <th>Sr. No.</th> <th>Address Bus</th> <th>Data Bus</th> </tr> </thead> <tbody> <tr> <td>1</td> <td>A bus that is used to specify a physical address in memory</td> <td>A bus that is used to transmit data among components</td> </tr> <tr> <td>2</td> <td>Unidirectional</td> <td>Bidirectional</td> </tr> <tr> <td>3</td> <td>Helps to transfer memory address of data and I/O</td> <td>Helps to send and receive data</td> </tr> <tr> <td>4</td> <td>16 bit address bus in 8051</td> <td>8 bit data bus in 8051</td> </tr> </tbody> </table>	Sr. No.	Address Bus	Data Bus	1	A bus that is used to specify a physical address in memory	A bus that is used to transmit data among components	2	Unidirectional	Bidirectional	3	Helps to transfer memory address of data and I/O	Helps to send and receive data	4	16 bit address bus in 8051	8 bit data bus in 8051	1M each (Any 2 points)
Sr. No.	Address Bus	Data Bus																
1	A bus that is used to specify a physical address in memory	A bus that is used to transmit data among components																
2	Unidirectional	Bidirectional																
3	Helps to transfer memory address of data and I/O	Helps to send and receive data																
4	16 bit address bus in 8051	8 bit data bus in 8051																
	b)	Calculate the number of address lines required to access 16 kB ROM.	2M															
	Ans:	14 address lines required to access 16 KB of ROM as $2^{14} = 16\text{KB}$	2M															
	c)	State features of ADC 0808.	2M															
	Ans:	<ol style="list-style-type: none"> 1. Easy to interface with all Microprocessors or works Stand alone. 2. Eight channel 8-bit ADC module. 3. Can measure up to 8 Analog values. 4. On chip Clock not available, external Oscillator is needed (Clock). 5. Digital output varies from 0 to 255, operating power is 15mW, conversion time 100us. 	1M each (Any 2 points)															
	d)	List specifications of 8051 microcontroller.	2M															
	Ans:	<ol style="list-style-type: none"> 1) 8- bit data bus and 8- bit ALU. 2) 16- bit address bus – can access maximum 64KB of RAM and ROM. 3) On- chip RAM -128 bytes (Data Memory) 4) On- chip ROM – 4 KB (Program Memory) 	1M each (Any 2 points)															



		<p>5) Four 8-bit bi- directional input/output ports Four 8-bit bi- directional input/ output ports.</p> <p>6) Programmable serial ports i.e. One UART (serial port)</p> <p>7) Two 16- bit timers- Timer 0& Timer 1</p> <p>8) Works on crystal frequency of 11.0592 MHz</p> <p>9) Has power down and idle mode in microcontroller when no operation is performed.</p> <p>10) Six interrupts are available.</p>									
e)	List any two instructions which makes accumulator zero individually.		2M								
Ans:	MOV A,#00H CLR A		1M each								
f)	Compare data memory and program memory.		2M								
Ans:	<table border="1"> <thead> <tr> <th>Sr.No.</th> <th>Program Memory</th> <th>Data Memory</th> </tr> </thead> <tbody> <tr> <td>1</td> <td>It is used for storing the hexadecimal codes of the program to be executed i.e. instructions.</td> <td>It is used for storing temporary variable data and intermediate results.</td> </tr> <tr> <td>2</td> <td>Program Memory of 8051 is 4kB</td> <td>Data Memory of 8051 is 128 bytes</td> </tr> </tbody> </table>	Sr.No.	Program Memory	Data Memory	1	It is used for storing the hexadecimal codes of the program to be executed i.e. instructions.	It is used for storing temporary variable data and intermediate results.	2	Program Memory of 8051 is 4kB	Data Memory of 8051 is 128 bytes	1M each
Sr.No.	Program Memory	Data Memory									
1	It is used for storing the hexadecimal codes of the program to be executed i.e. instructions.	It is used for storing temporary variable data and intermediate results.									
2	Program Memory of 8051 is 4kB	Data Memory of 8051 is 128 bytes									
g)	List SFR in 8051. (any four)		2M								
Ans:	<ul style="list-style-type: none"> • ACC and B registers – 8 bit each • DPTR : [DPH:DPL] – 16 bit combined • PC : Program Counter – 16 bits • Stack pointer SP – 8 bit • PSW : Program Status Word • Port Latches • Serial data buffer, serial control • Timer Registers (TCON,TMOD,TL0/1,TH0/1) • Power control • Interrupt Enable, Interrupt Priority 		½ M each								

Q.2	Attempt any THREE of the following:						12- Total Marks																					
a)	Compare any three derivatives of 8051 microcontroller on the basis of RAM,ROM,Timer and Interrupts.						4M																					
Ans:	<table border="1"> <thead> <tr> <th>Features</th> <th>8051</th> <th>8052</th> <th>89c52</th> <th>8031</th> <th>8751</th> <th>89v51 RD2</th> </tr> </thead> <tbody> <tr> <td>RAM</td> <td>128</td> <td>256</td> <td>256</td> <td>128</td> <td>128</td> <td>1k</td> </tr> <tr> <td>ROM</td> <td>4K (mask</td> <td>8K (EPROM)</td> <td>8K (Flash)</td> <td>0</td> <td>4K (UV-EPROM)</td> <td>64KB (FLASH)</td> </tr> </tbody> </table>						Features	8051	8052	89c52	8031	8751	89v51 RD2	RAM	128	256	256	128	128	1k	ROM	4K (mask	8K (EPROM)	8K (Flash)	0	4K (UV-EPROM)	64KB (FLASH)	1M each (Any 4 Points)
Features	8051	8052	89c52	8031	8751	89v51 RD2																						
RAM	128	256	256	128	128	1k																						
ROM	4K (mask	8K (EPROM)	8K (Flash)	0	4K (UV-EPROM)	64KB (FLASH)																						

			ROM)					
	TIMER	2	3	3	2	2	3	
	INTERRUPTS	6	8	8	6	6	8	

b) Draw and explain the interfacing of DAC to 8051. **4M**

Ans: Diagram: **2M**

- Microcontroller generates output which is in digital form but many controlling system requires analog signal as they don't accept digital data thus making it necessary to use DAC which converts digital data into equivalent analog voltage.
- In the figure shown, we use 8-bit DAC 0808. This IC converts 8 bit digital data into equivalent analog current. Hence we require an I to V converter to convert this current into equivalent voltage.

2M Explanation

c) Describe 8051 microcontroller as boolean processor. **4M**

Ans: **4M**

- 8051 processor is a CPU that can perform some operation on a data and gives the output.
- The 8051 processor contains a complete Boolean processor for single-bit operations.
- The internal RAM contains 128 addressable bits, and the SFR space supports up to 128 other addressable bits.
- All port lines are bit-addressable, and each can be treated as a separate single-bit port.
- The instructions that access these bits are not only conditional branches but also a complete set of move, set, clear, complement, OR, and AND instructions.
- The 8051 instruction set is optimized for the one bit operations. The Boolean processor provides direct support for bit manipulation and testing of individual bit allows the use of single bit variable to perform logical operations therefore 8051 can be used to solve Boolean expression. Bits may be set or cleared in a single instruction.
- Eg: CLR C means clear the carry bit
SETB 20h means set the memory bit with bit address 20h.

d) Explain function of following pins of 8051

(i) Pin 31
(ii) Pin 29
(iii) Pin 21-28

4M

Ans: i) **Pin 31-EA :** It is an active low I/P to 8051 microcontroller. When (EA)= 0, then 8051 microcontroller access from external program memory (ROM) only. When (EA) = 1,

1M- EA



	<p>then it access internal and external program memories (ROMS).</p> <p>ii) Pin 29- PSEN : This is an output pin. PSEN stands for “program store enable.” It is active low O/P signal. It is used to enable external program memory (ROM). When [PSEN(bar)]= 0, then external program memory becomes enabled and micro controller read content of external memory location. Therefore it is connected to (OE) of external ROM.</p> <p>iii) Pin 21-28: A₈ – A₁₅ : These pins are known as Port 2. It serves as I/O port. Each pin is bidirectional Input /Output with internal pull – up resistors. Besides the Input /Output, when external memory is interfaced, PORT 2 pins act as the higher-order address bus. (A8-A15)</p>	<p>1M- PSEN</p> <p>2M-Pin 21-28</p> <p>1M Port 2 & 1M A8 - A15</p>
Q.3	Attempt any THREE of the following:	12- Total Marks
a)	Develop Assembly Language program (ALP) to find the largest number in a block of 10 numbers stored at location 40H onwards in internal RAM.	4M
Ans:	<p>(NOTE: Marks to be given for any other correct logic used by students.)</p> <pre> ORG 0000H MOV R1, #0AH ; Initialize Byte Counter MOV R0, #40H ; Initialize source pointer R0 to 40H DEC R1 ; decrement counter by one MOV 60H, @R0 ;Read First Byte UP: INC R0 ; Increment the contents of R0 MOV A, @R0 ; Read second number CJNE A, 60H, DN ;compare the first two numbers, if not equal go to DN AJMP LARGE ;else go to LARGE DN: JC LARGE ;check carry MOV 60H, A ;Store largest number to 60H LARGE: DJNZ R1, UP ;decrement the counter by one, if count ≠ 0, then go to UP END Largest No. is saved in memory 60H. Assume any location to store the result. OR MOV R1, #0AH ; initialize the counter MOV R0, #40H ; initialize the memory pointer DEC R1 ; decrement counter by one MOV A,@R0 ; load number in accumulator MOV B, A ; move that number to register B UP: INC R0 ; increment the memory pointer MOV A,@R0 ; read the next number in A CJNE A, B, DOWN ; compare the first two numbers, if not equal go to DOWN AJMP NEXT ; else go to NEXT DOWN: JC NEXT ; if number in A is greater then go to NEXT MOV B, A ; else move the number in register B NEXT: DJNZ R1, UP ; decrement the counter by one, if count ≠ 0, then go to UP INC R0 ; increment the memory pointer MOV A,B MOV 50H, A ; store result at memory location 50H(Assume any location) HERE: SJMP HERE </pre>	4M for correct program



b) Sketch the internal memory organization in 8051.

4M

Ans: Daigram:

4M
for
neat
Sketch
with
label

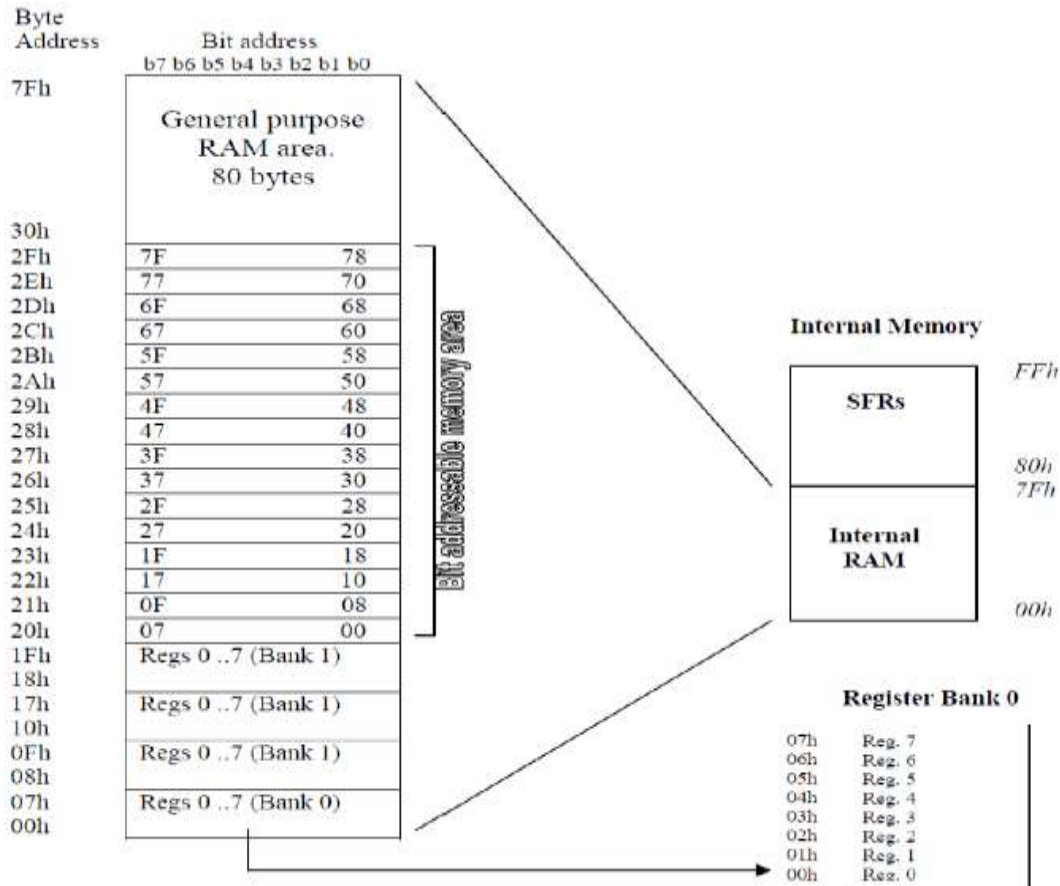

c) Explain processes of interrupt enabling and disabling in 8051.

4M

Ans: Interrupts are the events that temporarily suspend the main program, pass the control to the external sources and execute their task. It then passes the control to the main program where it had left off. 8051 has 5 interrupt signals, i.e. INT0, TF0, INT1, TF1, RI/TI. Each interrupt can be enabled or disabled by setting bits of the IE register and the whole interrupt system can be disabled by clearing the EA bit of the same register.

2M
forma
t

IE (Interrupt Enable) Register:

This register is responsible for enabling and disabling the interrupt. EA bit is set to 1 for enabling interrupts and set to 0 for disabling the interrupts. Its bit sequence and their meanings are shown in the following figure.

EA	-	-	ES	ET1	EX1	ET0	EX0
----	---	---	----	-----	-----	-----	-----

2M
functi
on of
each



EA	IE.7	It disables all interrupts. When EA = 0 no interrupt will be acknowledged and EA = 1 enables the interrupt individually.
-	IE.6	Reserved for future use.
-	IE.5	Reserved for future use.
ES	IE.4	Enables/disables serial port interrupt.
ET1	IE.3	Enables/disables timer1 overflow interrupt.
EX1	IE.2	Enables/disables external interrupt1.
ET0	IE.1	Enables/disables timer0 overflow interrupt.
EX0	IE.0	Enables/disables external interrupt0.

bit

d)

Explain following instructions of 8051.

- (i) **ADDC**
- (ii) **L CALL**

4M

Ans:

- (i) **ADDC:** The **ADDC** instruction adds a byte value and the value of the carry flag to the accumulator. The results of the addition are stored back in the accumulator. Several of the flag registers are affected.

ADDC

Function: Add with Carry

Syntax: **ADDC** A, source byte

Flags affected: **OV,AC,CY**

Description: **ADDC** simultaneously adds the byte variable indicated, the carry flag and the Accumulator contents, leaving the result in the Accumulator ($A = A + \text{byte} + \text{CY}$). The carry and auxiliary-carry or bit flags are set, respectively. If $\text{CY} = 1$ prior to this instruction, **CY** is also added to **A**.

Addressing modes supported for **ADDC** instruction :

- Immediate: **ADDC** A,#data
- Register: **ADDC** A, Rn
- Direct: **ADDC** A, address
- Register Indirect: **ADDC** A, @Ri

- (ii) **LCALL**

Function: Long call, Transfers control to a subroutine

Syntax: **LCALL** 16 bit addr

Flags affected : None

No. of bytes used: 3 byte(1 byte is opcode and other two bytes are the 16 bit address of the target subroutine)

Description: This instruction is used to transfers control to a subroutine To reach the target address in the 64 Kbytes maximum ROM space of the 8051, **LCALL** instruction is used. For calling a subroutine, the **PC** register (which has the address of the instruction after the **LCALL**) is pushed onto the stack, and the stack pointer (**SP**) is incremented by 2. Then the program counter is loaded with the new address and control is transferred to the subroutine.

2M
each
instru
ction



Q.4	Attempt any THREE of the following :	12 Marks								
a)	<p>Draw the format of TCON register of 8051 and describe the function of each bit of it.</p> <p>Ans: TCON: TIMER/COUNTER CONTROL REGISTER.BIT ADDRESSABLE</p> <table border="1" data-bbox="228 386 1417 453"> <tr> <td>TF1</td> <td>TR1</td> <td>TF0</td> <td>TR0</td> <td>IE1</td> <td>IT1</td> <td>IE0</td> <td>IT0</td> </tr> </table> <p>TF1 TCON. 7 Timer 1 overflows flag. Set by hardware when the Timer/Counter 1 Overflows. Cleared by hardware as processor vectors to the interrupt Service routine.</p> <p>TR1 TCON. 6 Timer 1 run control bit. Set/cleared by software to turn Timer/Counter1 ON/OFF.</p> <p>TF0 TCON. 5 Timer 0 overflow flag. Set by hardware when the Timer/Counter 0 Overflows. Cleared by hardware as processor vectors to the service routine.</p> <p>TR0 TCON. 4 Timer 0 run control bit. Set/cleared by software to turn Timer/Counter 0 ON/OFF.</p> <p>IE1 TCON. 3 External Interrupt 1 edge flag. Set by hardware when External Interrupt edge is detected. Cleared by hardware when interrupt is processed.</p> <p>IT1 TCON. 2 Interrupt 1 type control bit. Set/cleared by software to specify falling edge/low level triggered External Interrupt.</p> <p>IE0 TCON. 1 External Interrupt 0 edge flag. Set by hardware when External Interrupt edge detected. Cleared by hardware when interrupt is processed.</p> <p>IT0 TCON. 0 Interrupt 0 type control bit. Set/cleared by software to Specify falling edge/low level triggered External Interrupt</p>	TF1	TR1	TF0	TR0	IE1	IT1	IE0	IT0	4M 2M forma t 2M Functi on of each bit
TF1	TR1	TF0	TR0	IE1	IT1	IE0	IT0			
b)	<p>Describe serial communication in 8051. Explain the use of SCON register.</p> <p>Ans: 8051 micro controller communicate with another peripheral device through RXD and TXD pin of port3.controller have four mode of serial communication.</p> <p>1. Serial Data Mode-0 (Baud Rate Fixed) In this mode, the serial port works like a shift register and the data transmission works synchronously with a clock frequency of $f_{osc} / 12$. Serial data is received and transmitted through RXD. 8 bits are transmitted/ received at a time. Pin TXD outputs the shift clock pulses of frequency $f_{osc} / 12$, which is connected to the external circuitry for synchronization. The shift frequency or baud rate is always $1/12$ of the oscillator frequency.</p> <p>2. Serial Data Mode-1 (standard UART mode)(baud rate is variable) In mode-1, the serial port functions as a standard Universal Asynchronous Receiver Transmitter (UART) mode. 10 bits are transmitted through TXD or received through RXD. The 10 bits consist of one start bit (which is usually '0'), 8 data bits (LSB is sent first/received first), and a stop bit (which is usually '1'). Once received, the stop bit goes into RB8 in the special function register SCON. The baud rate is variable</p> <p>3. Serial Data Mode-2 Multiprocessor (baud rate is fixed) In this mode 11 bits are transmitted through TXD or received through RXD. The various bits are as follows: a start bit (usually '0'), 8 data bits (LSB first), a programmable 9 th (TB8 or RB8)bit and a stop bit (usually '1'). While transmitting, the 9 th data bit (TB8 in SCON) can be assigned the value '0' or '1'. For example, if the information of parity is to be transmitted, the parity bit (P) in PSW could be moved into TB8.On reception of the data, the 9 th bit goes into RB8 in 'SCON',</p>	4M 2M mode descri ption in short ($\frac{1}{2}$ mark for each mode) & 2M forma t with functi on								



while the stop bit is ignored. The baud rate is programmable to either 1/32 or 1/64 of the oscillator frequency.

$$f_{\text{baud}} = (2^{\text{SMOD}} / 64) f_{\text{osc}}$$

4. Serial Data Mode-3 - Multi processor mode(Variable baud rate)

In this mode 11 bits are transmitted through TXD or received through RXD. The various bits are: a start bit (usually '0'), 8 data bits (LSB first), a programmable 9th bit and a stop bit (usually '1'). Mode-3 is same as mode-2, except the fact that the baud rate in mode-3 is variable (i.e., just as in mode-1).

$$f_{\text{baud}} = (2^{\text{SMOD}} / 32) * (f_{\text{osc}} / 12 (256 - \text{TH1}))$$

SM0	SM1	SM2	REN	TB8	RB8	TI	RI
-----	-----	-----	-----	-----	-----	----	----

SM0 SCON.7 Serial port mode specifier

SM1 SCON.6 Serial port mode specifier.

SM0 SM1

0 0 Serial Mode 0

0 1 Serial Mode 1, 8-bit data, 1 stop bit, 1 start bit

1 0 Serial Mode 2

1 1 Serial Mode 3

SM2 SCON.5 Used for multiprocessor communication

REN SCON.4 Set/ cleared by software to enable/ disable reception.

TB8 SCON.3 – the 9th bit that will be transmitted in mode 2/3 set/clear by software.

RB8 SCON.2– in mode 2/3 it is the 9th bit that was received .

TI SCON.1 Transmit interrupt flag. Set by hardware at the beginning of the stop Bit in mode 1.

RI SCON.0 Receive interrupt flag. Set by hardware halfway through the stop bit time in mode 1.

c) **Draw interfacing of 16 × 2 LCD with 8051 and state the function of EN and RS of LCD** **4M**

Ans: **Diagram:** **2M for diagram**

2Marks for

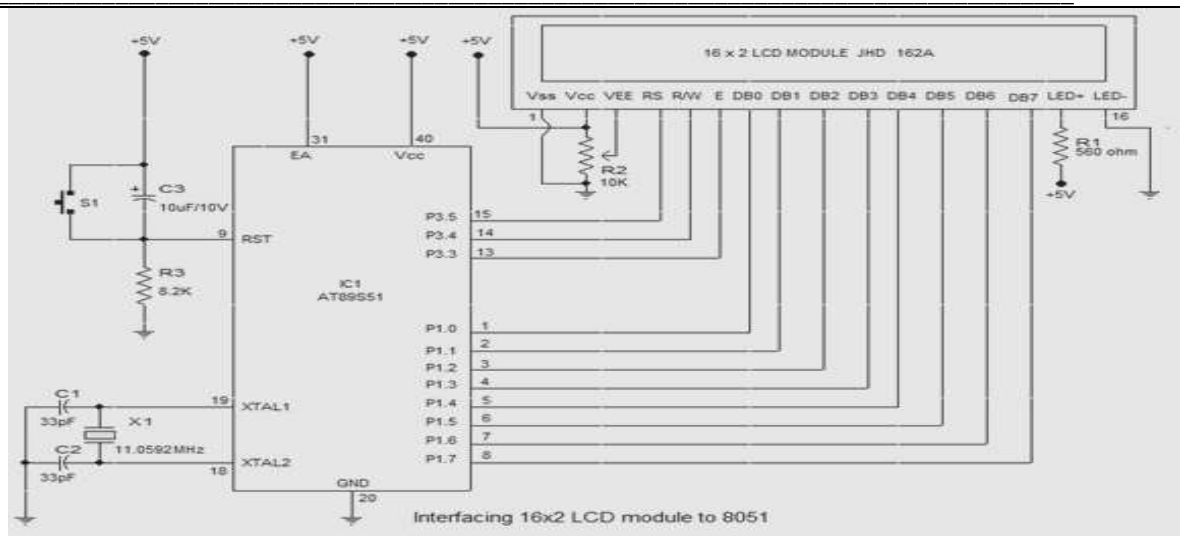

RS: RS is the register select pin. We need to set it to 1, if we are sending some data to be displayed on LCD. And we will set it to 0 if we are sending some command instructions during the initializing sequence like clear the screen etc.
EN: The enable pin is used by the LCD to latch information presented to its data pins. When data is supplied to the data pins, a high-to-low pulse must be applied to this pin in order for the LCD to latch in the data present at the data pins. This pulse must be a minimum of **450ns** wide.

function of two pins (1 Mark each pin function)

d) Explain the use of following assembler directives.

- (i) EQU
- (ii) ORG

4M

Ans:

- (i) EQU: Equate

It is used to define constant without occupying a memory location.

Syntax: Label EQU Numeric value

By means of this directive, a numeric value is replaced by a symbol.

For e.g. MAXIMUM EQU 99 After this directive every appearance of the label MAXIMUM in the program, the assembler will interpret as number 99 (MAXIMUM=99).

- (ii) ORG:-ORG stands for Origin

Syntax: ORG Address

The ORG directive is used to indicate the beginning of the address. The *origin directive* tells the assembler where to load instructions and data into memory. It changes the program counter to the value specified by the expression in the operand field. The number that comes after ORG can be either in hex or in decimal. If the number is not followed by H, it is decimal and the assembler will convert it to hex.

2 Marks for each directive

e) State the alternate pin functions of port 3 of 8051.

4M

Ans:	<table border="1"> <thead> <tr> <th>Pin</th> <th>Name</th> <th>Alternate Function</th> </tr> </thead> <tbody> <tr> <td>P3.0</td> <td>RXD</td> <td>Serial input line</td> </tr> <tr> <td>P3.1</td> <td>TXD</td> <td>Serial output line</td> </tr> <tr> <td>P3.2</td> <td>$\overline{INT0}$</td> <td>External interrupt 0</td> </tr> <tr> <td>P3.3</td> <td>$\overline{INT1}$</td> <td>External interrupt 1</td> </tr> <tr> <td>P3.4</td> <td>T0</td> <td>Timer0 external input</td> </tr> <tr> <td>P3.5</td> <td>T1</td> <td>Timer1 external input</td> </tr> <tr> <td>P3.6</td> <td>\overline{WR}</td> <td>External data memory write strobe</td> </tr> <tr> <td>P3.7</td> <td>\overline{RD}</td> <td>External data memory read strobe</td> </tr> </tbody> </table>	Pin	Name	Alternate Function	P3.0	RXD	Serial input line	P3.1	TXD	Serial output line	P3.2	$\overline{INT0}$	External interrupt 0	P3.3	$\overline{INT1}$	External interrupt 1	P3.4	T0	Timer0 external input	P3.5	T1	Timer1 external input	P3.6	\overline{WR}	External data memory write strobe	P3.7	\overline{RD}	External data memory read strobe	4 Marks for 8 pins(1/2 mark for each pin function)
	Pin	Name	Alternate Function																										
	P3.0	RXD	Serial input line																										
	P3.1	TXD	Serial output line																										
	P3.2	$\overline{INT0}$	External interrupt 0																										
	P3.3	$\overline{INT1}$	External interrupt 1																										
	P3.4	T0	Timer0 external input																										
	P3.5	T1	Timer1 external input																										
	P3.6	\overline{WR}	External data memory write strobe																										
P3.7	\overline{RD}	External data memory read strobe																											

Q.5	Attempt any TWO of the following	12 Total Marks
(a)	Explain with sketch the interfacing of 4 ×4 matrix keypad with 8051 microcontroller.	6M

Ans:		sketch -3M
	<p>Interfacing keypad</p> <p>Fig. shows how to interface the 4 X 4 matrix keypad to two ports in microcontroller. The rows are connected to an output port and the columns are connected to an input port.</p> <p>To detect a pressed key, the microcontroller grounds all rows by providing 0 to the output latch, and then it reads the columns. If the data read from the columns is D3-D0=1111, no key has been pressed and the process continues until a key press is detected. However, if one of the</p>	Expla nation – 3M



column bits has a zero, this means that a key press has occurred. For example, if D3-D0=1101, this means that a key in the D1 column has been pressed.

After a key press is detected, the **microcontroller** will go through the process of identifying the key. Starting with the top row, the **microcontroller** grounds it by providing a low to row D0 only; then it reads the columns.

If the data read is all 1s, no key in that row is activated and the process is moved to the next row. It grounds the next row, reads the columns, and checks for any zero. This process continues until the row is identified. After identification of the row in which the key has been pressed, the next task is to find out which column the pressed key belongs to.

(b)

Differentiate between

- (i) **Harvard and Von-neuman architecture**
- (ii) **Microprocessor and Microcontroller**

6M

Ans:

i) **Harvard Architecture and Von-neuman architecture**

Sr.No	Von Neumann architecture	Harvard architecture
1		
2	The Van Neumann architecture uses single memory for their instructions and data.	The Harvard architecture uses physically separate memories for their instructions and data.
3	Requires single bus for instructions and data	Requires separate & dedicated buses for memories for instructions and data.
4	Its design is simpler	Its design is complicated
5	Instructions and data have to be fetched in sequential order limiting the operation bandwidth.	Instructions and data can be fetched simultaneously as there is separate buses for instruction and data which increasing operation bandwidth.
6	Program segments & memory blocks for data & stacks have separate sets of addresses.	Vectors & pointers, variables program segments & memory blocks for data & stacks have different addresses in the program.

ii) **Microprocessor and Microcontroller**

Von
Nuem
ann
Harva
rd 3
M
(any
three
points
)

Micro
proces



Sr. No	Parameter	Microprocessor	Microcontroller
1.	No. of instructions used	Many instructions to read/ write data to/ from external memory.	Few instruction to read/ write data to/ from external memory
2.	Memory	Do not have inbuilt RAM or ROM.	Inbuilt RAM /or ROM
3.	Registers	Microprocessor contains general purpose registers, Stack pointer register, Program counter register	Microcontroller contains general purpose registers, Stack pointer register, Program counter register additional to that it contains Special Function Registers (SFRs) for Timer , Interrupt and serial communication etc.
4.	Timer	Do not have inbuilt Timer.	Inbuilt Timer
5.	I/O ports	I/O ports are not available requires extra device like 8155 or 8255.	I/O ports are available
6.	Serial port	Do not have inbuilt serial port, requires extra devices like 8250 or 8251.	Inbuilt serial port
7.	Multifunction pins	Less Multifunction pins on IC.	Many multifunction pins on the IC
8.	Boolean Operation	Boolean operation is not possible directly.	Boolean Operation i.e. operation on individual bit is possible directly
9.	Applications	General purpose, Computers and Personal Uses.	Single purpose(dedicated application), Automobile companies, embedded systems, remote control devices.

Microcontroller – 3M (any three points)

(c) Develop an ALP to generate square wave of 3 KHz using 8051 microcontroller on port pin P2.3 (Assume $X_{tal}freq^n=12$ MHz)

6M

Ans: Crystal frequency= 12 MHz
I/P clock = $(12 \times 10^6) / 12 = 1$ MHz
 $T_{in} = 1 \mu$ sec
For 3 kHz square wave
 $F_{out} = 3$ KHz $T_{out} = 1 / (3 \times 10^3) = 0.3$ msec = 333 μ sec
So $T_{ON} = T_{OFF} = 333 / 2 = 166.5 \mu$ sec
 $N = T_{ON} / T_{in} = 166.5 \mu$ sec / 1μ sec = 166.5 167
 $65535 - 167 + 1 = (65369)_{10} = (FB71)_{16}$
Program:-
MOV TMOD, # 01H ; Set timer 0 in Mode 1, i.e., 16 bit timer

Count calculation – 2M, Correct program – 4M

L2: MOV TL0, # 71 H ; Load TL register with LSB of count
 MOV TH0, # 0FB H ; load TH register with MSB of count
 SETB TR0 ; start timer 0
 L1: JNB TF0, L1 ; poll till timer roll over
 CLR TR0 ; stop timer 0
 CPL P2.3 ; complement port 2.3 line to get high or low
 CLR TF0 ; clear timer flag 0
 SJMP L2 ; re-load timer with count as mode 1 is not auto reload

Q.6

Attempt any TWO of the following:

12Total
Marks

(a)

Draw interfacing of stepper motor with 8051 and write an ALP to rotate it in clockwise direction.

6M

Ans:

Diagram:

3M

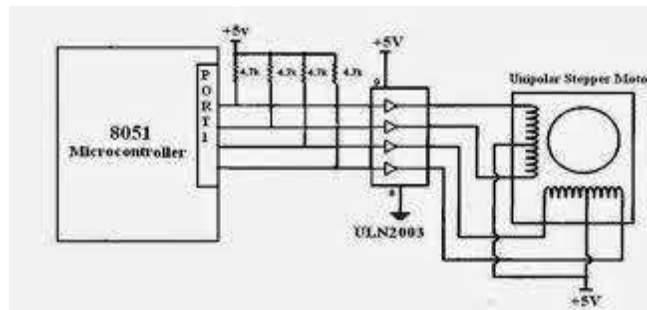

Step no	Winding A	Winding B	Winding C	Winding D	Clockwise
1	1	0	0	1	↓
2	1	1	0	0	
3	0	1	1	0	
4	0	0	1	1	

Program-



	<pre> BACK: MOV A,#66H ;load step sequence MOV P1,A ;issue sequence to motor RR A ;rotate right clockwise ACALL DELAY ;wait SJMP BACK ;keep going ... DELAY MOV R2,#100 H1: MOV R3,#255 H2: DJNZ R3,H2 DJNZ R2,H1 RET </pre> <p>(Other programs with similar logic can be given marks)</p>	3M
(b)	Describe with sketches the procedure to troubleshoot the traffic light controller.	6M
Ans:	<p>Considerations of Traffic Signal</p> <ol style="list-style-type: none"> 1) Traffic light may have sensors integrated to provide real time traffic information 2) Based on the traffic information provided by the sensor, the duration of the green/Red LED light for each direction may vary so that the traffic for both the directions are roughly balanced. Time left for the green light should be displayed 3) When the traffic light for one signal is green, then the traffic for the other directions should be red (with duration displayed in red) 4) The red light will be switched to yellow when the timer value is 5 sec before switching to red. <div style="text-align: center;"> </div> <ol style="list-style-type: none"> 5) Violations happen when user expectancy is not met. A user like pedestrian does not expect to stand for more than a minute or two at a signal, when this user expectancy is not met, the pedestrian tries to venture out and violate the signal 6) The smooth movement of conflicting vehicles is determined by the availability of gaps in traffic. This is true for both pedestrians and vehicular traffic. Understanding of gaps is important for justifying the type of traffic control device, including a traffic signal. <p>Points to consider for determining signal timings</p> <ol style="list-style-type: none"> 1) The signal operational parameters are reviewed and updated (if needed) on a regular basis to maximize the ability of the traffic control signal to satisfy current traffic demands 	Any other correct troubleshooting procedure may be given marks

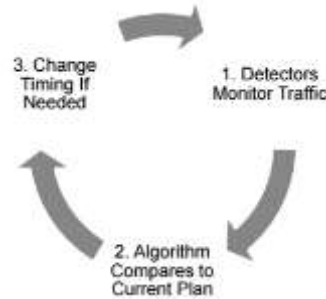

- 2) Geometry of the intersection is the next step in the signal timing process. Determining the lane use (which traffic mode), dedicated vs. shared lane, type of roads interacting (arterial with arterial etc.), type of road infrastructure (ramps, one way streets, etc.) will impact the timing.
- 3) Basic signal timing parameters comes next. Pedestrian walk times, flashing don't walk, yellow time, all red clearance interval, detector gap times all need to be calculated or established.
- 4) Identify bottlenecks, review conditions, conduct warrant analysis and use engineering judgment in determining traffic signal installation
- 5) Determine AM and PM peak hour traffic volumes.
- 6) Condition diagram which includes roadway geometrics, parking, driveways, sidewalks, signing, pavement markings, development of intersection quadrants, and any other features pertinent to the study peak hour delay study
- 7) A conflict analysis
- 8) Capacity analysis of the intersection for current and future years using growth

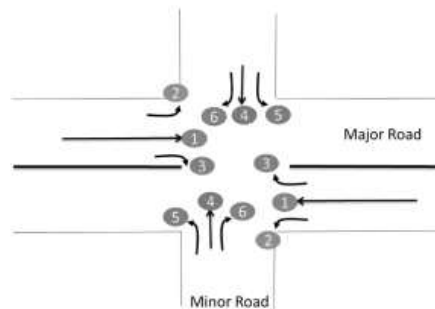

(c)

Draw and explain Internal port structure of Port 0 and Port 1 of 8051 microcontroller.

6M

Ans:

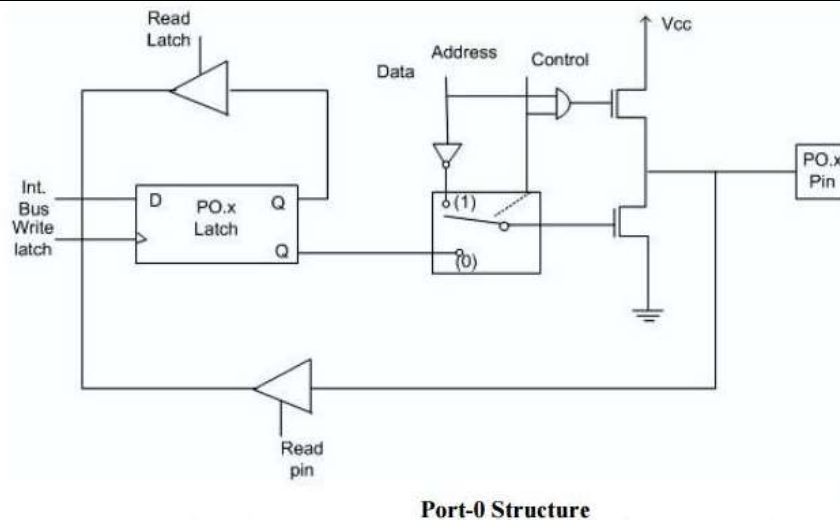

Port-0 can be configured as a normal bidirectional I/O port or it can be used for address/data interfacing for accessing external memory. When control is '1', the port is used for address/data interfacing. When the control is '0', the port can be used as a normal bidirectional I/O port.

Let us assume that control is '0'. When the port is used as an input port, '1' is written to the latch. In this situation both the output MOSFETs are 'off'. Hence the output pin floats. This high impedance pin can be pulled up or low by an external source. When the port is used as an output port, a '1' written to the latch again turns 'off' both the output MOSFETs and causes the output pin to float. An external pull-up is required to output a '1'. But when '0' is written to the latch, the pin is pulled down by the lower MOSFET. Hence the output becomes zero.

When the control is '1', address/data bus controls the output driver MOSFETs. If the address/data bus (internal) is '0', the upper MOSFET is 'off' and the lower MOSFET is 'on'. The output becomes '0'. If the address/data bus is '1', the upper transistor is 'on' and the lower transistor is 'off'. Hence the output is '1'. Hence for normal address/data interfacing (for external memory access) no pull-up resistors are required.

Port-0 latch is written to with 1's when used for external memory access.

**Port 0
– 3M**

**Port 1
– 3M**

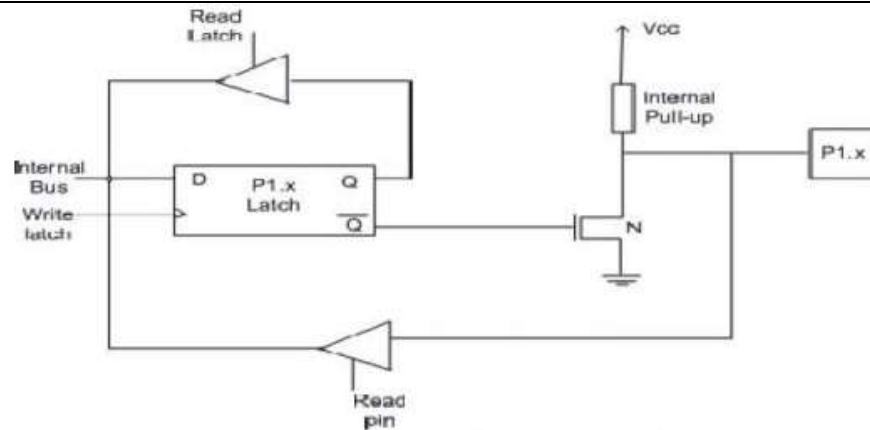

Port 1 Structure

Port-1 does not have any alternate function i.e. it is dedicated solely for I/O interfacing. When used as output port, the pin is pulled up or down through internal pull-up. To use port-1 as input port, '1' has to be written to the latch. In this input mode when '1' is written to the pin by the external device then it read fine. But when '0' is written to the pin by the external device then the external source must sink current due to internal pull-up. If the external device is not able to sink the current the pin voltage may rise, leading to a possible wrong reading.