



WINTER – 19 EXAMINATION

Subject Name: Tool Engineering

Model Answer

Subject Code:

22565

Important Instructions to examiners:

- 1) The answers should be examined by key words and not as word-to-word as given in the model answer scheme.
- 2) The model answer and the answer written by candidate may vary but the examiner may try to assess the understanding level of the candidate.
- 3) The language errors such as grammatical, spelling errors should not be given more importance (Not applicable for subject English and Communication Skills).
- 4) While assessing figures, examiner may give credit for principal components indicated in the figure. The figures drawn by candidate and model answer may vary. The examiner may give credit for any equivalent figure drawn.
- 5) Credits may be given step wise for numerical problems. In some cases, the assumed constant values may vary and there may be some difference in the candidate's answers and model answer.
- 6) In case of some questions credit may be given by judgement on part of examiner of relevant answer based on candidate's understanding.
- 7) For programming language papers, credit may be given to any other program based on equivalent concept.

| Q. No. | Sub Q. N. | Answer | Marking Scheme |
|--------|-----------|---|------------------|
| 1 | | Attempt any FIVE | 5 x 2 =10 |
| | a) Ans | <p>State the principle of Tool Engineering</p> <p>Tool Engineering is a division of Production and Industrial Engineering. Its function is to plan the process of manufacture, develop various tools and machines and integrate facilities required for producing particular products with minimal expenditure of time, labour and material. Coursework is designed to include the art of designing jigs, fixtures, press tools, creating die casting designs, plastic moulds designs, mastering advanced plastic processing technologies and becoming perfect in metrology and measurements.</p> <p>It includes metal cutting, pressing, and various work holding devices. Metal cutting is the operation in which thin layer of metal is removed by wedge shaped tool. Metal cutting is commonly associated with industries like automotive, aerospace, home appliance, etc. The machining of metal and alloys play a crucial role in the range of manufacturing activities including ultra precision machining of extremely delicate components to improve efficiency and productivity.</p> | 02 |
| | b) Ans | <p>Define the term Die clearance.</p> <p>Die clearance is the total space between cutting edge of die and punch. A correct clearance between the punch and the die assures normal wear of the tool and punching without defect such as: burrs on the piece in the case of excessive clearance and premature wearing of the tool and increased punching force in the case clearance being too small</p> | 02 |



| | | | |
|--|-----------------------------|---|------------------------------|
| | | <p style="text-align: center;"> $\text{Total Die Clearance} = \text{Die clearance both sides of Punch}$ $\text{Total Die Clearance} = \text{Die Clearance 1} + \text{Die Clearance 2}$ </p> | |
| | <p>c)</p> <p>Ans</p> | <p>List the applications of CBN inserts</p> <ol style="list-style-type: none"> 1. Abrasives products. 2. Polycrystalline materials . 3. Metal processing for grinding. 4. Precision Machining. 5. CNC Machines Tools. | <p>Any Four ½ Mark Each</p> |
| | <p>d)</p> <p>Ans</p> | <p>State the functions of Locating Devices</p> <ol style="list-style-type: none"> 1] It should ensure workpieces are precisely positioned and rigidly supported. 2] It should be selected to ensure that the workpiece can be easily loaded and unloaded. 3] It should always contact a workpiece on machined surface. 4] It should be positioned as far apart as possible. This will ensure the use of fewer locators and permits complete contact over the locating surface. 5] It should be fool proof. | <p>Any Four ½ Mark Each</p> |
| | <p>e)</p> <p>Ans</p> | <p>Define the term Fixture</p> <p>A fixture is a work-holding or support device used in the manufacturing industry. Fixtures are used to securely locate (position in a specific location or orientation) and support the work, ensuring that all parts produced using the fixture will maintain conformity and interchangeability. It does not guide the cutting tool. Using a fixture improves the economy of production by allowing smooth operation and quick transition from part to part, reducing the requirement for skilled labor by simplifying how workpieces are mounted, and increasing conformity across a production run.</p> | <p>02</p> |
| | <p>f)</p> <p>Ans</p> | <p>List any four applications of Press tool</p> <ol style="list-style-type: none"> 1. Blanking 2. Piercing 3. Bending 4. Forming 5. Forging 6. Trimming 7. Parting 8. Drawing | <p>Any Four ½ Marks Each</p> |
| | <p>g)</p> <p>Ans</p> | <p>Name the operations performed using Drawing operation</p> <ol style="list-style-type: none"> 1. Deep Drawing 2. Shallow Drawing 3. Bar drawing 4. Tube Drawing 5. Wire Drawing | <p>Any four ½ Mark Each</p> |



| | | | |
|---|-----------|--|--|
| 2 | | Attempt any THREE | 3 x 4 = 12 |
| | a) Ans | <p>Explain Merchant's Circle with neat sketch.</p> <p>Merchant's Force Circle is a method for calculating the various forces involved in the cutting process. The procedure to construct a merchants force circle diagram (using drafting techniques/instruments) is,</p> <ol style="list-style-type: none"> 1. Set up x-y axis labeled with forces, and the origin in the centre of the page. The scale should be enough to include both the measured forces. The cutting force (F_c) is drawn horizontally, and the tangential force (F_t) is drawn vertically. (These forces will all be in the lower left hand quadrant) (Note: square graph paper and equal x & y scales are essential) 2. Draw in the resultant (R) of F_c and F_t. 3. Locate the centre of R, and draw a circle that encloses vector R. If done correctly, the heads and tails of all vectors will lie on this circle. 4. Draw in the cutting tool in the upper right hand quadrant, taking care to draw the correct rake angle (α) from the vertical axis. 5. Extend the line that is the cutting face of the tool (at the same rake angle) through the circle. This now gives the friction vector (F). 6. A line can now be drawn from the head of the friction vector, to the head of the resultant vector (R). This gives the normal vector (N). Also add a friction angle (τ) between vectors R and N. As a side note recall that any vector can be broken down into components. Therefore, mathematically, $R = F_c + F_t = F + N$. 7. We next use the chip thickness, compared to the cut depth to find the shear force. To do this, the chip is drawn on before and after cut. Before drawing, select some magnification factor (e.g., 200 times) to multiply both values by. Draw a feed thickness line (t_1) parallel to the horizontal axis. Next draw a chip thickness line parallel to the tool cutting face. 8. Draw a vector from the origin (tool point) towards the intersection of the two chip lines, stopping at the circle. The result will be a shear force vector (F_s). Also measure the shear force angle between F_s and F_c. 9. Finally add the shear force normal (F_n) from the head of F_s to the head of R. 10. Use a scale and protractor to measure off all distances (forces) and angles. <p>The resulting diagram is pictured below,</p> <p>If students write derivation then it is also accepted.</p> | <p>02 Marks Explanation</p> <p>02 Marks Sketch</p> |

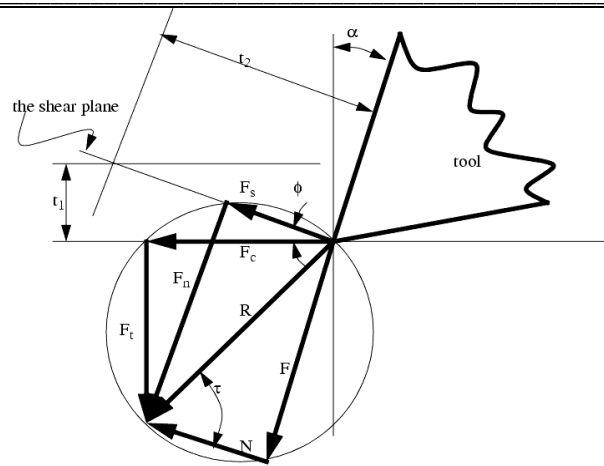

F_s = shear force
 F_n = force normal to shear plane
 α = tool rake angle (positive as shown)
 ϕ = shear angle
 τ = friction angle

Assumptions made while drawing a Merchant circle diagram.

1. The shear plane is always acting upwards.
2. The cutting edge is too sharp.
3. Chip width is constant.
4. The Depth of cut is constant.
5. No built-up-edge is formed.

b) Enlist the properties of Cutting tool materials

Ans Basic properties that cutting tool materials are:-

1. Tool material must be at least 30 to 50% harder than the work piece material.
2. Tool material must have high hot hardness temperature.
3. High toughness.
4. High wear resistance.
5. High thermal conductivity.
6. Lower coefficient of friction.
7. Easiness in fabrication and cheap.
8. Resist Shock loads.

Any Eight 1/2
Each

c) Differentiate between clamping and locating devices.

Ans

Locating devices:-

- 1] The workpieces position are accurately position with respect to tool guiding or setting elements in fixtures.
- 2] Locators should be positioned to contact the work on a machine surface.
- 3] Locators should be fool proof i.e the component can only be loaded into the fixture in the correct position.
- 4] Location features should be swarf traps and should have clearance provided where necessary to clear machining burrs.

Clamping devices

- 1] The workpieces are held securely in located position during operations.
- 2] Clamping should be exerted on solid supporting of the work to prevent distortion.
- 3] Clamping should be sufficient to hold the component to avoid bending.

Any Four
1 Mark Each



| | | | |
|----------|-------------------------|--|---|
| | | 4] Clamp should be positively guided to facilitate loading action | |
| | d) Ans | <p>Classify Jigs</p> <p>Type of jigs</p> <ol style="list-style-type: none"> 1. Closed Jig 2. Plate Jig 3. Sandwich Jig 4. Angle plate jig 5. Box Jig 6. Channel Jig 7. Trunnion Jig 8. Pump Jig 9. Indexing Jig 10. Template jig 11. Multi section Jig 12. special jig 13. Leaf Jig 14. Latch Jig | Any Eight ½ Mark Each |
| 3 | | Attempt any THREE | 3 x 4 =12 |
| | a) | <p>a) Explain with neat sketch importance of ‘Scrap strip layout’. In the blanking die-set design, the first step is to prepare blanking layout i.e. the position of the work pieces in the strip and their orientation with respect to each other. This is known as Scrap Strip Layout. Importance of scrap strip layout due to following factors</p> <p>1. Economy of Material: As per arrangement in below fig. below it can be worked at single row, single pass with a single punch.</p>  <p>2. By feeding the material as per below fig. there is increase in maximum material utilization upto some extent.</p>  <p>3. Below figure shows a single row, double pass strip. Here, strip will have to be passed through the dies once turned over and passed through dies second time. Hence, there is a maximum utilization of the material and reduction in scrap</p> | <p>4 Marks</p> <p>(Sketch is for 1 mark)</p> <p>and</p> <p>(3 Marks for Explanation)</p> |

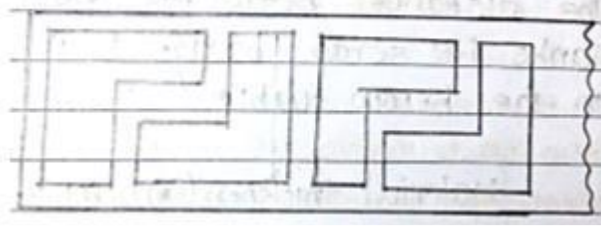

4. Scrap strip layout gives an idea on the **positioning** of various **punches, stops and pilots**

b) State the Causes of spring back:

Ans

- i. Spring back increases as hardness of stock material increases.
- ii. Thickness of stock material.
- iii. Spring back is directly proportional to the bend radius.
- iv. Due to the displacement of molecules and the other considers Spring Back in terms of a stress-strain diagram.
- v. Also one of the reasons for Spring Back is that as the material is bent the inner region of the bend is compressed while the outer region is stretched. This means that the molecular density is greater on the inside of the bend.
- vi. The compressive strength of material is greater than its tensile strength. This means that pressure will permanently deform the outer regions of the piece before it deforms the inner regions. The compressive stress is changed into Spring Back

4 Marks

(any four points)

c) Classify the Dies. List their application

Ans

Dies are Classified based on cutting and shearing action

- Blanking dies
- Piercing dies
- Perforating dies
- Lancing
- Notching
- Trimming
- Shaving
- Nibbling dies

Dies are Classified based on method of operation

- Simple dies
- compound dies
- combination dies
- progressive dies
- transfer dies
- multiple dies

Application:

1. Aircraft/Aerospace industry
2. Boiler manufacturing
3. Pressure vessel, tank manufacturing
4. Chassis, door, cabinets in Automobile Industry
5. Chemical processing equipment and Jewelry
6. Food & beverage – grain dryers, sorting machines, fruit and vegetable juice presses, cheese molds, baking trays, coffee screens.
7. Tube notching is in the manufacture of bicycle frames

4 Marks

(2 Marks for classification)
Any classification should give marks

And

(2 marks for any two Application)

| | | |
|-------------------|--|---|
| <p>d) Ans</p> | <p>Explain with neat sketch construction of Solid heel clamp.</p> <div style="text-align: center;"> <p>Fig. Solid heel clamp</p> </div> <p>The simple form of a heel clamp is shown in Figure. These consist of a plate, center stud and solid heel. This trap should be strengthening at the point where the hole for the stud is cut out, by increasing the thickness around the hole. Rotation of the clamp in clockwise direction is prevented and it is allowed in anticlockwise direction. For releasing the workpiece the clamping nut is unscrewed to guide its sliding motion for loading and unloading. The free movement in anticlockwise direction takes places before un-securing the nut to release the workpiece</p> | <p>4 Marks</p> <p>(Sketch is for 2 marks. and 2 Marks for Explanation)</p> |
| <p>e) Ans</p> | <p>Explain Following term:</p> <p>i) Bend Radius: 2 Marks Distance between bend center and neutral axis is known as bend radius. It is denoted by 'r'. Bend radius, which is measured to the inside curvature, is the minimum radius one can bend a pipe, tube, sheet, cable or hose without kinking it, damaging it, or shortening its life. The smaller the bend radius, the greater is the material flexibility</p> <p>ii) Bend Allowance: 2 Marks The length of the neutral axis in the bend zone is known as bend allowance. Bend allowance: For calculating the blank length for bending the length of material in the curved section or bend area has to be calculated. This length in the bend area which will be more than the corresponding length of blank before bending is called as 'Bend Allowance'.</p> | <p>4 Marks</p> <p>(2 Marks each term)</p> |
| <p>4</p> | <p>Attempt any TWO</p> | <p>2 X 6 =12</p> |
| <p>a) Ans</p> | <p>Explain with neat sketch 'Orthogonal Cutting process'.</p> <ol style="list-style-type: none"> 1. The cutting edge of the tool remains normal to the direction of tool feed or work feed. Or Cutting edge of the tool is perpendicular to the direction of travel of the tool. 2. The direction of the chip flow velocity is normal to the cutting edge of the tool. 3. Here only two components of forces are acting: Cutting Force and Thrust Force. So, the metal cutting may be considered as a two dimensional cutting. | <p>6 Marks</p> <p>(Sketch is for 2 marks any figure should give marks)</p> |

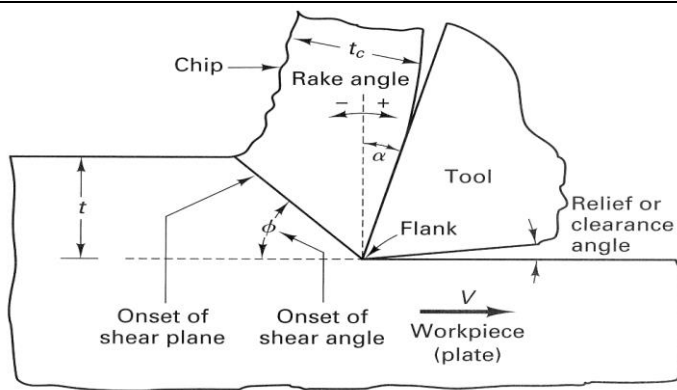

(c) Orthogonal plate machining with fixed tool, moving plate.

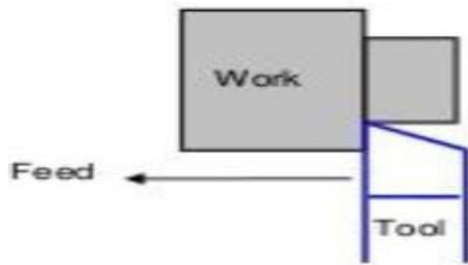

Orthogonal Cutting

4. Example: **Parting** operation in turning is Orthogonal.
5. Maximum chip thickness occurs at the middle.
6. Due to smaller area of the tool, less friction in between work-tool interface therefore tool life is more.
7. Cutting edge clears the width of the workpiece on either ends.
8. The chip coils are tight and flat spiral.
9. Generation of continuous chips that affects the final surface integrity.
10. Less tool wear due to straight cutting action.
11. Higher depth of cuts may be possible for softer materials.
12. Generation of less cutting forces that affects the final surface integrity.
13. Moderate surface finished on machined components.

And

(4 Marks for proper Explanation)

b) **Write the application of following tool material-Ceramics, PCBN, HSS.**

Ans

Ans:

Ceramics: 2 Marks

1. Retain hardness upto 1400°C so used for high cutting speeds and high production rate
2. Used on hard to machine work materials hardness as high as 65 Rc and high temp alloys such as monel, stellite and hastelloy.
3. Also employed for roll turning, long tube boring and cylinder liner boring.
4. Alumina used on abrasive in grinding wheels.

PCBN: 2 Marks

1. Extensively used on abrasive in grinding wheels for fine finishing of HSS tool, hard or high strength alloy steel and stainless steel.
2. Grinding of hardened steel lead screw, bores, splines, threads, parts of ball and roller bearing and hardened cast iron slideways of machine tool etc.
3. Tool tip and inserts made from cubic boron nitride are capable of machining hardened tool steel, chilled cast iron, high strength and heat resistant alloy.

6 Marks

(2 Marks for each term

and

any two application of each term)



| | | |
|-------------------|---|---|
| | <p>HSS: 2 Marks</p> <ol style="list-style-type: none"> Used for making drill and reamers, milling cutters, turning tools, taps, dies, broach, hobs, etc. Solid tool of HSS HSS Inserts: shanks are friction welded to HSS cutting ends. HSS strips are Electron beam welded to low alloy steel for making band saws. Indexable HSS insets for CNC | |
| <p>c) Ans</p> | <p>Explain the term degree of freedom. State its importance while selecting, locating and clamping devices.</p> <p>Ans:</p> <p>Degrees of Freedom :</p> <div data-bbox="609 651 1096 1050" data-label="Diagram"> </div> <p>Fig. Degree of Freedom</p> <p>A workpiece free in space can move in an infinite number of directions. For analysis, this motion can be broken down into twelve directional movements, also called as degrees of freedom. Any rectangular body has selected three axes along <i>x</i>-axis, <i>y</i>-axis and <i>z</i>-axis. It can move along any of these axes or any of its movement can be released to these three axes. As the double-headed arrows indicate, the translational and rotational positions six axial & six radial can vary in either direction with respect to each of the three axes. These twelve coordinates are known as the twelve degrees of freedom of a three-dimensional object.</p> <p>Importance of Locating:</p> <ol style="list-style-type: none"> 1] A desired relationship between the workpiece and the jigs or fixture correctness of location directly influences the accuracy of the finished product. 2] Any locator is to reference the workpiece and to ensure repeatability/Interchangeability. 3] Restrict the undesired movement and rotation of workpiece. 4] Determine the position of the workpiece with respect to cutting tool. <p>Importance of clamping device:</p> <ol style="list-style-type: none"> (a) It should rigidly hold the workpiece. (b) The workpiece being clamped should not be damaged due to application of clamping pressure by the clamping unit. (c) The clamping pressure is enough to overcome the Operating pressure/Cutting Force applied on the workpiece as both pressure acts on the workpiece in opposite | <p>6 Marks</p> <p>(1 Mark for figure of degree of freedom)</p> <p>(1 Mark for explanation for selecting and DOF)</p> <p>(2 Marks for Locating importance any two points)</p> <p>(2 Marks for clamping importance any two points)</p> |



| | | | |
|---|-----|---|---------------------|
| | | <p>directions.</p> <p>(d) Clamping device is capable to be unaffected by the vibrations generated during an operation.</p> <p>(e) It should also be user friendly, like its clamping and releasing should be easy and less time consuming. Its maintenance will also be easy.</p> <p>f) Clamping pressure is directed towards the support surfaces or support points to prevent undesired lifting of workpiece from its supports.</p> <p>(g) Clamping faces is hardened by proper treatments to minimize their wearing out.</p> <p>(h) To handle the workpieces made of fragile material the faces of clamping unit is equipped with fiber pads to avoid any damage to workpiece.</p> | |
| 5 | | Attempt any Two | 2 x 6 = 12 M |
| | a) | Explain the procedure of designing fixture for milling machine in detail | |
| | Ans | <p>Designing of milling fixture involves following design stages</p> <p>[1] The milling component analysis with respect to the dimensions, degree of freedom is carried out</p> <p>[2] Operator safety, processing equipment, ease of use is considered on milling machine</p> <p>[3] All the critical dimensions and feasible datum areas of milling component are examined</p> <p>[4] Degree of freedom need to be arrested are decided</p> <p>[5] In further steps the clamping scheme is designed in such a manner that it will be easy to clamp and unclamp component without damaging it.</p> <p>[6] In Next step the locating pins are designed in such a manner that it will not interfere with tools or milling cutters</p> <p>[7] Tool guiding schemes are designed which are to be consistent with clamping and tool guiding arrangements</p> <p>[8] Finally there is the design of the structure of the fixture body frame. This is generally built up around the workpiece and usually single element which links all the other elements used for locating, clamping, tool guiding into integral frame work</p> | 6 Marks |
| | b) | <p>The washers of 25 mm outer diameter & 10 mm inner diameter are to be made by press operation from M S Sheet of 1 mm thickness Calculate</p> <p>(i) Clearance</p> <p>(ii) Size of punch and die</p> | |
| | Ans | <p>(i) Clearance :</p> <p>5 % of the thickness t</p> $C = 0.05 \times 1$ | 2 Mark [A] |



| | | |
|----|--|--|
| | <p style="text-align: center;">$= 0.05 \text{ mm}$ _____ [A]</p> <p>(ii) Size of punch and die.</p> <p>Blanking die opening size is equal to blank size. But to allow for expansion of blank, die opening should be made smaller, thus</p> <p>Blank die opening = $25 - 0.05$</p> <p style="text-align: center;">$= 24.95 \text{ mm}$ _____ [B]</p> <p>Blanking punch size = Blanking die opening - 2C</p> <p style="text-align: center;">$= 24.95 - 2 \times 0.05$</p> <p style="text-align: center;">$= 24.85 \text{ mm}$ _____ [C]</p> <p>Punch size is made larger to compensate elastic recovery</p> <p>Piercing Punch size = $10 + 0.05$</p> <p style="text-align: center;">$= 10.05$ _____ [D]</p> <p>Piercing die size = Piercing Punch size + 2C</p> <p style="text-align: center;">$= 10.05 + 2 \times (0.05)$</p> <p style="text-align: center;">$= 10.15 \text{ mm}$ _____ [E]</p> <p style="text-align: center;">OR</p> <p>(iii) Size of punch and die.</p> <p>Blank die opening = Blank size = 25.00 mm _____ [B]</p> <p>Blanking punch size = Blanking die opening - 2C</p> <p style="text-align: center;">$= 25.00 - 2 \times 0.05$</p> <p style="text-align: center;">$= 24.90 \text{ mm}$ _____ [C]</p> <p>Punch size is made larger to compensate elastic recovery</p> <p>Piercing Punch size = Hole size (dia) = 10 mm _____ [D]</p> <p>Piercing die size = Piercing Punch size + 2C</p> <p style="text-align: center;">$= 10.00 + 2 \times (0.05)$</p> <p style="text-align: center;">$= 10.10 \text{ mm}$ _____ [E]</p> <p>Note :- The given problem can solve by any one of the above way, Consider any one solution out of the above two</p> | <p style="text-align: right;">1 Mark [B]</p> <p style="text-align: right;">1 Mark [C]</p> <p style="text-align: right;">1 Mark [D]</p> <p style="text-align: right;">1 Mark [E]</p> <p style="text-align: center;">OR</p> <p style="text-align: right;">1 Mark [B]</p> <p style="text-align: right;">1 Mark [C]</p> <p style="text-align: right;">1 Mark [D]</p> <p style="text-align: right;">1 Mark [E]</p> |
| c) | Determine the developed length of part shown in Figure. Assume $K = t/3$ | |

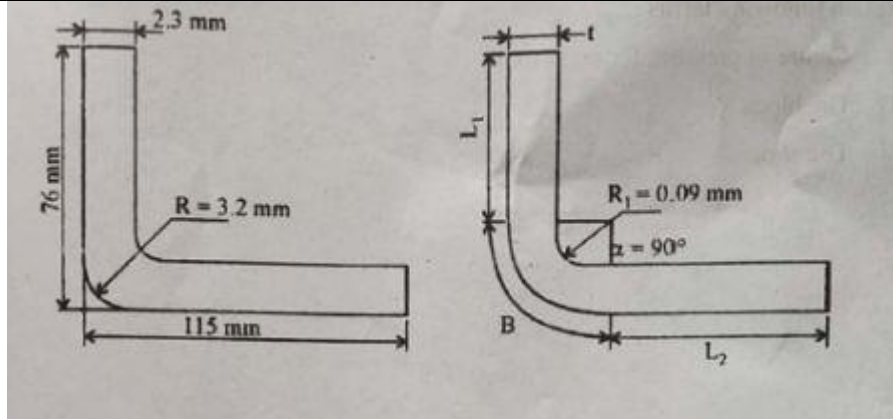

Ans

While calculating the developed length for bending, external dimensions should be converted to internal dimensions.

Developed length = L1 + L2 + B _____ Formula

The inside radius of bend, $r = 3.2 - 2.3 = 0.90 \text{ mm}$ _____ [A]

Length L1 = $76 - (2.3 + 0.90) = 72.8 \text{ mm}$ _____ [B]

Length L2 = $115 - (2.3 + 0.90) = 111.8 \text{ mm}$ _____ [C]

Bend allowance $B = \alpha / 360 \cdot 2 \pi (r + K)$

$\alpha = 90^\circ$ $K = t/3$

$B = 90/360 \cdot 2 \pi (0.90 + 2.3/3)$

$= 2.61 \text{ mm}$ _____ [D]

Developed Length = $72.8 + 111.8 + 2.61 = 187.21 \text{ mm}$ _____ [E]

1 Mark for Formula

1 Mark [A]

1 Mark [B]

1 Mark [C]

1 Mark [D]

1 Mark [E]

6

Attempt any Two

2 X 6 = 12 M

a)

Explain with neat sketch the construction of jig for drilling four equispaced through radial holes in a ring

Ans

This type of jig is equipped with the facility of indexing, which creates positional division of the work piece suitably. This jig is used for quick drilling of equidistant holes on the circular surface of the work piece. By means of indexing device a hole is drilled then the work piece is moved (indexed) to next position under the drill bush for drilling automatically. Indexing jigs are used to accurately space holes or other machined areas around a part. To do this, the jig uses either the part itself or a reference plate and a plunger. Larger indexing jigs are called rotary jigs.

4 Marks for explanation

&

2 Marks for neat sketch

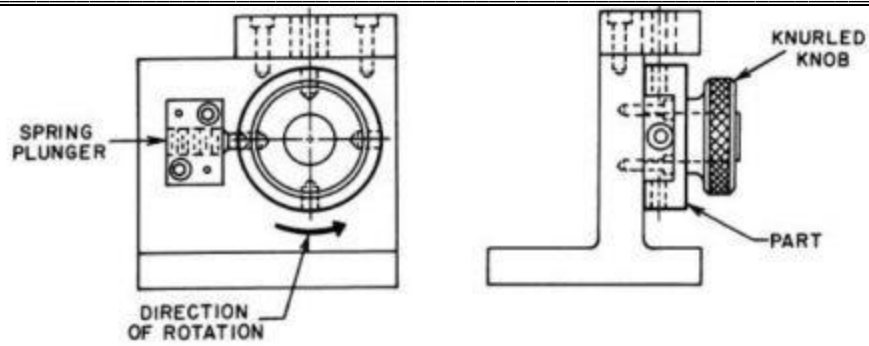

b) The figure given below shows a cup to be drawn.

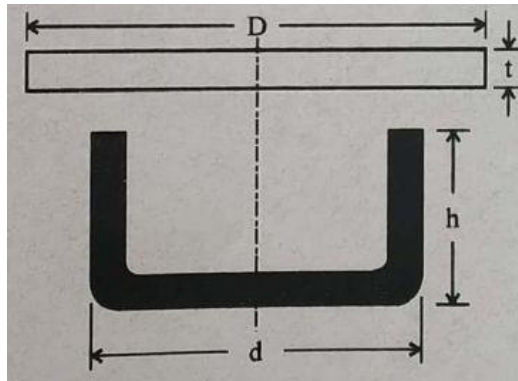

Shell Diameter $d = 60 \text{ mm}$

Radius of bottom corner of shell = 2.0 mm

Height of cup = 50 mm

Do not consider trimming of blank

- (i) Calculate the diameter of blank from it
- (ii) Calculate the percentage reduction
- (iii) Calculate the number of draw

Ans

(i) Size of blank $= d / r$
 $= 60 / 2$
 $= 30 \text{ mm}$ _____ [A]

Diameter of Blank $= D = \sqrt{d^2 + 4dh}$
 $= \sqrt{60^2 + 4 \times 60 \times 50}$
 $D = 124.89 \text{ mm}$ _____ [B]

(ii) Percentage Reduction $= 100 \left(1 - \frac{d}{D} \right)$
 $= 100 \left(1 - \frac{60}{124.89} \right)$
 $= 52.5 \%$ _____ [C]

(iii) Number of Draw =
 Height to diameter Ratio = $50/60$

1 Mark [A]

1 Mark [B]

2 Mark [C]



| | | | |
|--|------------|--|--------------------------------------|
| | | $= 0.8333$ _____ [D] | 1 Mark [D] |
| | | Ratio lies between 0.7 to 1.5 & hence number of draws are 2 _____ [E] | 1 Mark [E] |
| | C) | Explain the following terms (i) Centre of pressure (ii) Die block (iii) Die shoe | |
| | Ans | <p>(i) Centre of pressure</p> <p>When the shape of blank to be cut is irregular, the summation of shear forces about the centre line of press ram may not be symmetrical. Due to this, bending moments will be introduced in the press ram, producing misalignment and undesirable deflections. To avoid this “centre of pressure” of the shearing action of the die must be found and while laying out the punch position on the punch holder, it should be ensured that the centre line of press ram passes exactly through the centre of pressure of the blank. This “centre of pressure” is the centroid of the line perimeter of the blank. It should be noted that it is not the centroid of the area of the blank.</p> <p>(ii) Die Block</p> <p>It is a block or a plate which contains a die cavity. Die block is the female half of the two mated tools which carry the cutting edges. It is subjected to extreme pressures and wear conditions. Hence a die block is made of a superior quality of tool steel.</p> <p>(iii) Die Shoe</p> <p>Die shoes are generally two types 1] upper shoe 2] Lower shoe. Upper shoe is a part of die set and usually contains guide post bushings. Lower shoe is generally mounted on the bolster plate of a press. The die block is mounted on the lower shoe. Also the guide posts are mounted in it.</p> | 2 Marks each for correct explanation |