

Scheme – I

Sample Question Paper

Program Name : Diploma in Information Technology
Program Code : IF
Semester : Third
Course Title : Digital Techniques and Microprocessor
Max. Marks : 70

22323

Time: 3 Hrs.

Instructions:

- 1) All questions are compulsory.
- 2) Illustrate your answers with sketches wherever necessary.
- 3) Figures to the right indicate full marks.
- 4) Assume suitable data if necessary.
- 5) Any calculator is not permissible.
- 6) Preferably, write the answers in sequential order.

Q.1) A) Attempt any FIVE of the following.

10 Marks

- a. Define
 - i. Byte
 - ii. Nibble.
- b. Describe Necessity of Multiplexer & Demultiplexer
- c. State Four applications of flip-flops.
- d. Write use of Index registers, base pointer, and Instruction pointer.
- e. Write one application each of basic logic gate.
- f. List any Four addressing modes and give one example of each

Q.2) A) Attempt any THREE of the following.

12 Marks

- a) Convert the following octal number into Hexa-decimal number
 - i) $(626)_8$
 - ii) $(2571)_8$
- b) Simplify the given min-term into standard SOP form:
$$Y\{P,Q,R,S\} = (P + \bar{R} + S) + (\bar{Q} + R + \bar{S})$$
- c) Draw symbol and truth table of JK flip flop and D flip flop.
- d) Simplify following expression and draw logic diagram.

$$Y = (A \bar{B} + A + \bar{B}) A.B$$

Q.3) A) Attempt any THREE of the following.

12 Marks

- a) Construct the following gates using NAND gate. Write necessary outputs of gates.
 - i) AND
 - ii) OR
- b) Interpret the given program and specify the output for following situations:
MOV AX, 34F9H

MOV BX, 3A69H

- i) Masking of lower nibble of AX.
 - ii) Rotate right through carry contents of BX by 4 positions.
 - iii) Shift Left contents of BX by 6 positions.
 - iv) XOR AX,BX
- c) Explain level triggered and Edge triggered with proper diagram.
- d) Represent following expression using Multiplexer:
- $Y = \Sigma m(0,1,2,4,6,11,13,15)$

Q.4) A) Attempt any THREE of the following.

12 Marks

- a) Explain the concept of physical address calculation with suitable diagram and example.
- b) Draw half adder using basic gates and specify it's truth table.
- c) Draw symbol and write truth table for following flip-flops with one example of each.
 - i) Clocked SR flip flop.
 - ii) T flip flop
- d) Compare features of Microprocessor 8086 with Pentium processor III on the basis of following parameters :
 - Memory size
 - Address bus/ data bus width
 - Clock speed (MHz)
 - Modes of operation
- e) Reduce the following Boolean expression and draw the logical diagram for reduced expression.

$$Y = A.B.C + \bar{A} . \bar{B}.C + A.B. \bar{C} + \bar{A}. \bar{B}. \bar{C}$$

Q.5) A) Attempt any TWO of the following.

12 Marks

- a) Write an Assembly Language Program with algorithm for finding largest Number. from the array of 10 Numbers.(Assume Suitable data)
- b) Refer given figure and Write the output(s) for each of the following input.

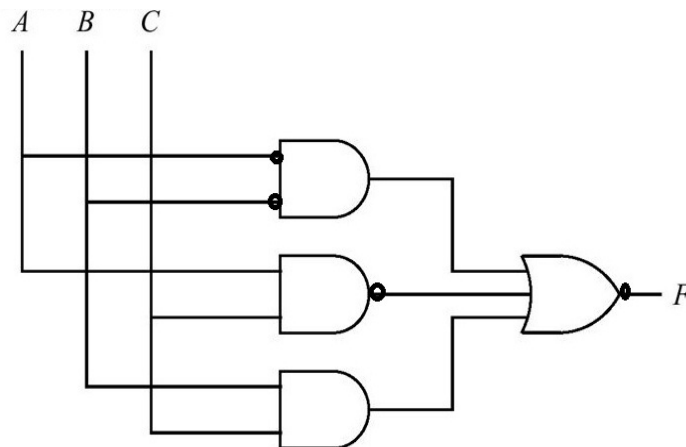

Refer given figure and Write the output(s) for each of the following input.

A	B	C	F
0	0	0	
0	0	1	
0	1	0	
0	1	1	
1	0	0	
1	0	1	
1	1	0	
1	1	1	

- c) Draw maximum mode configuration of 8086 and explain any four control signals generated by bus controller.

Q.6) A) Attempt any TWO of the following.

12 Marks

- Describe pipelined architecture concept of CISC, which helps in improving system throughput?
- Design half Subtractor using NOR gate only. Write truth table.
- Write algorithm and Assembly Language Program for find whether the no. is even or odd.

Scheme – I

Sample Test Paper - I

Program Name : Diploma in Information Technology
Program Code : IF
Semester : Third
Course Title : Digital Techniques and Microprocessor
Max. Marks : 20

22323

Time: 1 Hour

Instructions:

- 1) All questions are compulsory.
- 2) Illustrate your answers with sketches wherever necessary.
- 3) Figures to the right indicate full marks.
- 4) Assume suitable data if necessary.
- 5) Any calculator is not permissible.
- 6) Preferably, write the answers in sequential order.

Q.1 Attempt any FOUR.

08 Marks

- a) Define
 - i) Byte
 - ii) Nibble.
- b) State significance of Combinational Logic circuit
- c) Define min-term and max-term
- d) Construct OR gate using NOR Gate.
- e) Which basic gate will be used in following situation:
 - i) Where two inputs are different and output is high.
 - ii) Complement the given input.
- f) Define min-term and max-term and give one example of each.

Q.2 Attempt any THREE.

12 Marks

- a) Compare TTL and CMOS logic families on the basis of
 - i) Propagation delay
 - ii) Fan-in
 - iii) Fan-out
 - iv) Power dissipation
- b) Represent following expression using K-map.
 - i) $Y = \sum m(0,1,2,4,5,6)$
 - ii) $Y = \sum \Pi (0,2,4,5)$
- c) Draw AND gate using NAND gate only and NOR gate only
- d) Convert the following Boolean equation into standard SOP form
 - i) $Y = AB + A.B + BC$
 - ii) $Y = AB + B(B+C) + AB$

Scheme – I

Sample Test Paper - II

Program Name : Diploma in Information Technology
Program Code : IF
Semester : Third
Course Title : Digital Techniques and Microprocessor
Max. Marks : 20

22323

Time: 1 Hour

Instructions:

- 1) All questions are compulsory.
- 2) Illustrate your answers with sketches wherever necessary.
- 3) Figures to the right indicate full marks.
- 4) Assume suitable data if necessary.
- 5) Any calculator is not permissible.
- 6) Preferably, write the answers in sequential order.

Q.1 Attempt any FOUR.

08 Marks

- a) Define Sequential Logic circuit
- b) Draw Flag register of 8086 with proper labeling
- c) Define addressing mode and Give one example of any one addressing mode.
- d) Find physical address of operand NUM1 for given data.
DS: 4300H, CS= 1200H, SP = 0500H, IP = 234H
- e) Write instruction for 8 bit and 16 bit operations from following with its syntax:
 - Addition with carry
 - signed multiplication
- f) List any four characteristic of CISC processor

Q.2 Attempt any THREE.

12 Marks

- a) Explain positive edge triggering and negative edge triggering.
- b) Compare 8086 microprocessor with Pentium III (any four parameters).
- c) State TWO assembler directives of following with suitable example.
 - Related to segment
 - Related to procedure
- d) Draw labeled architecture of 8086 microprocessor.
- e)