



Summer – 2018 Examinations

Subject Code: 17506 (ECA)

Model Answers

Page No: 1 of 23

Important Instructions to examiners:

- 1) The answers should be examined by key words and not as word-to-word as given in the model answer scheme.
- 2) The model answer and the answer written by candidate may vary but the examiner may try to assess the understanding level of the candidate.
- 3) The language errors such as grammatical, spelling errors should not be given more importance (Not applicable for subject English and Communication Skills).
- 4) While assessing figures, examiner may give credit for principal components indicated in the figure. The figures drawn by candidate and model answer may vary. The examiner may give credit for any equivalent figure drawn.
- 5) Credits may be given step wise for numerical problems. In some cases, the assumed constant values may vary and there may be some difference in the candidate's answers and model answer.
- 6) In case of some questions credit may be given by judgment on part of examiner of relevant answer based on candidate's understanding.
- 7) For programming language papers, credit may be given to any other program based on equivalent concept.



Summer – 2018 Examinations

Subject Code: 17506 (ECA)

Model Answers

Page No: 2 of 23

1 A Attempt any THREE of the following:

12

1 A a) State the functions of National Productivity Councils (any 4)

Ans:

Functions of National Productivity Councils:

- i. Consultancy to organizations on productivity improvement
- ii. Training to personnel at different levels
- iii. Dissemination of Productivity information through seminars, workshops, conferences, etc.
- iv. Productivity Research and Database
- v. Productivity Publications
- vi. Productivity Awards

1 Mark for
each of any
four
= 4 Marks

1 A b) Define the following terms and state their units:

(i) Luminous intensity, (ii) Luminous flux

Ans:

i) **Luminous intensity:** This is defined as the luminous flux emitted into a solid angle of space in a specific direction. Its unit is the candela.

OR

The luminous flux per unit solid angle (per steradian), as measured in a given direction relative to a light source. Its unit is the candela.

ii) **Luminous Flux:** The luminous flux is the total energy radiated by the light source in all direction. The unit of luminous flux is lumen (lm)

2 Marks for
each
definition
and units
= 4 Marks

1 A c) Explain energy conservation technique “by improving power quality” for induction motor.

Ans:

Energy Conservation by Improving power quality for Induction Motor:

- 1) Voltage
- 2) Frequency
- 3) Closeness of the supply to sine waveform, which also is a means for knowing the harmonic content of the supply.

1) **Voltage:** Maintaining the voltage at the rated value for motors results in the properly expected torque speed characteristics available to drive the load. Lower voltage leads to excessive current drawn due to which the line losses increase, machine copper losses increase, line voltage drops increase. Even if voltage is above required value higher flux density results in motors that leads to higher iron losses. These lead to decrease in efficiency. Hence proper voltage has to be maintained.

2) **Frequency:** It governs the speed related losses and iron losses. If its value is more than rated these losses increase as speed is directly proportional to the frequency the speed dependent friction & windage losses increase that will decrease the efficiency. Lower value of frequency leads to lower speed that affects the output power. Hence frequency has to be maintained at rated value.

3) When the supply waveform is purely sinusoidal the harmonics are absent which means no iron & copper losses due to harmonic voltage & currents. Also the harmonics even if very small lead to production of unwanted harmonic torques in motors which need to be overcome & this requires energy which is wasteful. Hence

4 Marks for
correct
explanation



the supply voltage must be as near as possible to sine wave in case of AC motors.

- 1 A d) State and explain any four factors governing selection of induction motor.

Ans:

The factors governing the selection of Induction motor:

- 1) Load torque required at normal speed matches with available torque of motor.
- 2) Break down torque or pull out torque or maximum torque must match with the maximum torque requirement by load.
- 3) Starting torque of motor must be more than that needed by load.
- 4) The duty or load cycle of the motor determines the motor's thermal loading, hence it should be such that sufficient time is available for cooling between the cycles.
- 5) The torque speed characteristics available from the motor must match the requirements of the load.
- 6) The environment/atmosphere in which the motor is to be installed govern the motor operating characteristics required. e.g. Corrosive atmospheres, dusty atmospheres, high temperature spaces need properly chosen motors for drives.
- 7) Cost of the motor plays an important role if a range is available.
- 8) Easily procurable, quick and easily serviceable motors are normally preferred. Standard motors are normally preferred.
- 9) Normally while selecting motors its performance is verified from the test certificate.
- 10) The power factor (reactive power drawn) and performance between 70% load to 100% load are considered. A motor having good characteristics in this regards will be always be preferred.
- 11) If selecting energy efficient motor the cost benefit analysis over the long run must be worked out.

1 Mark for
each of any
four factors
= 4 Marks

1 B Attempt any ONE of the following:

6

- 1 B a) Describe the following energy conservation methods of electrical motor.

- i) By motor survey
- ii) By matching loads with motor rating

Ans:

Energy conservation methods of electrical motor:

1) By Motor Survey:

Large industries have a massive population of LT motors. Load survey of LT motors can be taken-up methodically to identify improvement options.

i) Sampling Criteria:

Towards the objective of selecting representative LT motor drives among the motor population, for analysis, the criteria considered are:

- Utilization factor i.e., hours of operation with preference given to continuously operated drive motors.
- Sample representative basis, where one drive motor analysis can be reasoned as representative for the population. e.g. Cooling Tower Fans, Air Washer Units, etc.
- Conservation potential basis, where drive motors with inefficient capacity controls on the machine side, fluctuating load drive systems, etc., are looked into.

3 Marks



ii) Measurements:

Studies on selected LT motors involve measurement of electrical load parameters namely volts, amperes, power factor, kW drawn.

Observations on machine side parameters such as speed, load, pressure, temperature, etc., (as relevant) are also taken. Availability of online instruments for routine measurements, availability of tail-end capacitors for PF correction, energy meters for monitoring is also looked into for each case.

iii) Analysis

Analysis of observations on representative LT motors and connected drives is carried out towards following outputs:

- Motor load on kW basis and estimated energy consumption.
- Scope for improving monitoring systems to enable sustenance of a regular in-house Energy Audit function.
- Scope areas for energy conservation with related cost benefits and source information.

The observations are to indicate:

% loading on kW, % voltage unbalance if any, voltage, current, frequency, power factor, machine side conditions like load / unload condition, pressure, flow, temperature, damper / throttle operation, whether it is a rewound motor, idle operations, metering provisions, etc.

The findings / recommendations may include:

- Identified motors with less than 50 % loading, 50 – 75 % loading, 75 – 100 % loading, over 100 % loading.
- Identified motors with low voltage / power factor / voltage imbalance for needed improvement measures.
- Identified motors with machine side losses / inefficiencies like idle operations, throttling / damper operations for avenues like automatic controls / interlocks, variable speed drives, etc.

Motor load survey is aimed not only as a measure to identify motor efficiency areas but equally importantly, as a means to check combined efficiency of the motor, driven machine and controller if any. The margins in motor efficiency may be less than 10 % of consumption often, but the load survey would help to bring out savings in driven machines / systems, which can give 30 – 40 % energy savings.

2) By matching loads with motor rating

Industrial motors frequently operate under varying load conditions due to process requirements. A common practice in cases where such variable-loads are found is to select a motor based on the highest anticipated load. In many instances, an alternative approach is typically less costly, more efficient, and provides equally satisfactory operation. With this approach, the optimum rating for the motor is selected on the basis of the load duration curve for the particular application. Thus, rather than selecting a motor of high rating that would operate at full capacity for only a short period, a motor would be selected with a rating slightly lower than the peak anticipated load and would operate at overload for a short period of time. Since operating within the thermal capacity of the motor insulation is of greatest concern in a motor operating at higher than its rated load, the motor rating is selected as that which would result in the same temperature rise under continuous full-load operation as the weighted average temperature rise over the actual operating cycle. Under extreme load changes, e.g. frequent starts / stops, or high inertial loads, this



Summer – 2018 Examinations

Subject Code: 17506 (ECA)

Model Answers

Page No: 5 of 23

method of calculating the motor rating is unsuitable since it would underestimate the heating that would occur.

Where loads vary substantially with time, in addition to proper motor sizing, the control strategy employed can have a significant impact on motor electricity use. Traditionally, mechanical means (e.g. throttle valves in piping systems) have been used when lower output is required. More efficient speed control mechanisms include multi-speed motors, eddy-current couplings, fluid couplings, and solid-state electronic variable speed drives.

1 B b) Describe the following energy conservation methods of lighting system.

i) By replacing lamp sources ii) Using light control gears.

Ans:

Energy conservation methods of lighting system:

i) By replacing lamp sources:

- Installation of energy efficient fluorescent lamps in place of “Conventional” fluorescent lamps.
- Installation of metal halide lamps in place of mercury / sodium vapour lamps.
- Installation of High Pressure Sodium Vapour (HPSV) lamps for applications where colour rendering is not critical.
- Installation of LED panel indicator lamps in place of filament lamps etc.

3 Marks

ii) Using light control gears

The simplest and the most widely used form of controlling a lighting installation is "On-Off" switch.

- Grouping of lighting system, to provide greater flexibility in lighting control (manual or automatic)
- Installation of microprocessor/ infrared controlled dimming or switching circuits.
- Advanced lighting control system uses movement detectors or lighting sensors, to feed signals to the controllers.
- Optimum usage of day lighting in combination with electric lighting.
- Installation of exclusive transformer for lighting. It will reduce the voltage related problems, which in turn increases the efficiency of the lighting system.
- Installation of high frequency (HF) electronic ballasts in place of conventional ballasts which saves energy up to 35%.

3 Marks

2 **Attempt any FOUR of the following:**

16

2 a) Define Luminance and state recommended luminance level of any four different locations:

Ans:

Luminance: It is the illuminance per unit solid angle, measured in lumens/meter²/sr.

OR

Luminance is the density of visible radiation in a given direction.

1 Mark for definition

Recommended luminance level of any four different locations: (Any 4)



Summer – 2018 Examinations

Subject Code: 17506 (ECA)

Model Answers

Page No: 6 of 23

- i. Homes, restaurants, general lighting, emergency lighting : 8-18 lumens/watts
- ii. Offices, shops, hospitals, homes : 46-60 lumens/watts
- iii. Hotels, shops, homes, offices : 40-70 lumens/watts
- iv. General lighting in factories, garages, car parking, flood lighting :44-57 lumens/watts
- v. Display, flood lighting, stadium exhibition grounds, construction areas: 18-24 lumens/watts
- vi. General lighting in factories, ware houses, street lighting :67-121 lumens/watts
- vii. Roadways, tunnels, canals, street lighting :101-175 lumens/watts

3 Marks for
luminance
levels

OR

Hospital

- 1 Reception & Nursing 250 to 300 lux station
- 2 Corridors & circulation 40 to 60 lux areas
- 3 Patient wards - 100 to 200 lux
- 4 Operation theatres - 600 to 1000 lux
- 5 ICU - 500 to 700 lux
- 6 General ward 100 to 200 lux

Sports

- 1 Badminton court 750 Lux
- 2 Carrom Hall 500 Lux
- 3 Table Tennis Hall 500 Lux
- 4 Basket Ball Court 500 Lux 7 Special ward 150 to 250 lux etc.

Residential purpose

1. Living Room 300 Lux
2. Bedroom 200 Lux
3. Kitchen 200 Lux
4. Stairs 100 Lux
5. Dining Room 150 Lux
6. Dressing table 200 Lux
7. Bathroom mirror 700 Lux
8. Study table 300 Lux

- 2 b) Explain energy conservation method in lighting system by using installation of separate transformer / servo stabilizer.

Ans:

Energy conservation techniques by installation of separate transformer / servo stabilizer:

The luminous efficiency of lamps depends upon the voltage applied across the terminals. It gives its best output at rated voltage. Small reduction in applied voltage greatly reduces its luminous output. Therefore, it is necessary that the voltage applied across them is properly maintained constant. This can be achieved by installing a transformer substitution near the load so that variation in voltage will be negligible. However, to such sub-station, different categories of loads are connected, which may act in such a way that there may be sudden voltage drop. When such loads are made off, it may result in sudden rise of voltage, which certainly affects the luminous efficiency of the lamps.

To obtain constant luminous output in particular installation it is necessary to stabilize the voltage. Hence for such purposes, servo stabilizers are connected in the system of

4 Marks for
correct
explanation



such premises, which will maintain the voltage constant in that installation for giving best luminous efficiency of lamps.

- 2 c) Explain any two energy conservation techniques in fan.

Ans:

Following are energy conservation techniques in Fans :

1) Use the electronic regulators instead of conventional regulator:

Function of regulator is to control the speed of the fan. The conventional regulators use a resistance having taps and connected in series with the fan. Considerable amount of energy is lost in form of heat in the resistance. When the fan is operating at low speed the power loss is significant.

The electronic fan regulator uses TRIAC, a semiconductor device. In electronic regulators voltage is varied by varying the firing angle. Since the voltage supplied is proportional to the speed and hence the speed of the fan can be increased or decreased. An average saving of 27% can be achieved under reduced speed, if the fan is used along with an electronic type regulator against a conventional type regulator. Though the initial cost of an electronic regulator is high, the higher savings will pay back the investor in less than 10 months.

2 Marks for
each of
2 techniques
with correct
explanation
= 4 Marks

2) Use of energy efficient fans (motor):

Energy efficient motor can be used in fans for reducing energy consumption.

3) Use of windows to allow Natural air circulation:

Keep open your windows to allow natural air circulation. This will enable you to reduce the fan usage or to operate the fan at reduced speed, to reduce your energy consumption energy bill.

4) Make sure to turn your fan OFF when you leave the home, office or industry:

Switch OFF fans whenever not required or you are leaving your home, class room, office or industry.

5) Use of properly designed blades:

Whole house fans are large, powerful fans usually 20-48 inches in diameter with a one-quarter to one-half horsepower motor.

6) Timely and proper maintenance of fans:

Don't forget to properly maintain your electric fan and keep it in good working order.

- 2 d) State the need of energy conservation in electrical motor.

Ans:

The need of energy conservation in electrical motor:

- i) Electric motors are a major part of the industrial arena (about 60% to 70%) and consume a huge amount of energy, 60 % of agriculture load, 40% of commercial load and 23 % of residential load.
- ii) Cost of electricity is increasing.
- iii) For maximum savings motors must work at higher efficiencies.
- iv) Production costs cannot be reduced till the operating costs of machines used therein are reduced without sacrificing the quality.
- v) Most of the electricity produced and utilized to drive the electrical motors comes from the burning of precious fuels or using natural resources as coal, oil etc.
- vi) Inefficient motors need large powers of which a major portion is lost.

1 Mark for
each of any
four points
= 4 Marks



- 2 e) State the need of energy conservation in transformer.

Ans:

Need of energy conservation in transformer:

In electrical power system, transformers are used to change the voltage levels of different sections as per the need of economic and efficient operation of the system.

Since the transformers are integral part of power system and large in numbers, whether they are on load or no load, they always remain on line.

The power losses in windings (no load primary copper losses due to no load current) and magnetic core (due to rated voltage across primary) results in energy wastage.

As rated voltage and no load current are there around the clock reduction in these losses in transformer, leads to large amount of energy savings over the period, which can be used for some other good reason. Therefore, there is need of energy conservation in transformer.

4 Marks

- 2 f) State and explain any four technical losses in transmission and distribution systems.

Ans:

Technical losses :

- i) Copper losses
- ii) Unbalance loading
- iii) Long length of distribution lines
- iv) Conductor of inadequate size
- v) Various losses in transformer
- vi) Long distance between transformer and load center
- vii) Low power factor
- viii) Load factor
- ix) Reactive power
- x) Improper joints and connection

1 Mark for
each of any
four
= 4 Marks

i) Copper losses:

Copper loss is a major aspect in which all the real power of the distribution system is lost. As $P_{cu} = I^2R$ change in value of current will contribute more loss. Skin effect will also cause copper loss.

ii) Unbalance loading:

If any phases are more heavily loaded as compared to other ones, losses would definitely be higher than it would have been if lines were loaded evenly. Balancing line currents in distribution system may lead to considerable loss saving.

iii) Long length of distribution lines:

In rural areas loads are scattered over large areas causing extension of distribution lines. Hence primary and secondary distribution network spreads over long distances. Resistance varies directly with length and resistivity and inversely with cross sectional area. So for the same magnitude of line current longer line will have more losses than shorter.

iv) Conductors of Inadequate Size:

Scattered loads of distribution systems are fed by radial feeders which generally features inappropriate size of conductors. Conductor of smaller size will cause more losses than conductor of larger size.

v) Losses in Transformer:

Various losses in transformer such as Copper losses, Core losses will contribute more. Copper losses are due to I^2R losses are due to winding resistances and current



Summer – 2018 Examinations

Subject Code: 17506 (ECA)

Model Answers

Page No: 9 of 23

flowing the windings. The core losses are due to eddy current and hysteresis loss.

vi) Long distance between transformer and load center:

Generally transformers are located far away from the consumers instead of any suitable center location. Though secondary voltage is maintained properly, consumer which is far away receives very low voltages at his end.

vii) Low power factor:

In primary and secondary distribution system power factor may be observed as low as 0.65 to 0.75. If power factor is low, current drawn is high for the given load. Hence lower the power factor higher the current and higher the losses associated with square of the current.

viii) Load factor:

Power consumption of consumers varies over different timings of day as well as seasons. Peak power consumption differs varies with category of consumers. Load factor is a measure of load variation and ranges from 0 to 1. More the demand variation over the feeder, lower the load factor and higher the energy loss.

viii) Reactive Power:

Reactive power is the part of the power, which is not utilized by the consumer. It is taken during switching on and fed back to the supply when switched off. Reactive power is caused by energy storage components, e.g. inductors, capacitors.

ix) Improper joints and connections:

Improper joints and connection ensures loose connections. If pressure between the connections is not properly maintained and not inspected time to time for the same, it leads to sparking and heating in contacts. Bad workmanship may be the reason behind this which is due to less interest of the line men in their work.

3. Attempt any FOUR of the following:

16

- 3 a) Compare conventional induction motor with energy efficient motor on the basis of following points: (i) Noise (ii) Cost (iii) Effect of voltage fluctuations (iv) Efficiency.

Ans:

Particulars	Energy efficient motor	Conventional motor
Noise	Noise and vibration level is less	Noise is More
Cost	More	Less
Effect of Voltage fluctuations	Less	More
Efficiency	More efficient	Less efficient

1 Mark each
= 4 Marks

- 3 b) Explain energy conservation technique in induction motor by minimizing idle and redundant running of motor.

Ans:

Energy conservation technique in induction motor by minimizing idle and redundant running of motor:

- 1) Loss of energy as the no load power drawn is approximately about 12% to 16% of rated power output in most of motors. Therefore, idle running should be avoided.
- 2) Unnecessary heat production at friction points such as bearings, leading to wearing of bearing.
- 3) Motor being highly inductive load under idle running as no real power (mechanical load) on it, the p.f. of such no-load running is low, leading to unnecessary line

4 Marks



losses.

4) Reduction in overall system energy efficiency over period of time.

3 c) Explain any four advantages of amorphous transformer.

Ans:

Advantages of amorphous core transformer:

- 1) Lowest hysteresis loss.
- 2) Low eddy current loss.
- 3) Low temperature rise.
- 4) Up to 75% energy saving using amorphous metal than conventional metal.
- 5) Reduced carbon dioxide emission.
- 6) Reduction in fossil fuel consumption.
- 7) Reduced magnetizing current.
- 8) Better overload capacity.
- 9) High Reliability.
- 10) Excellent short circuit capacity.
- 11) Less maintenance cost.

1 Mark for
each of any
four
= 4 Marks

3 d) State any four periodical maintenance which is necessary in transformer to achieve energy conservation.

Ans:

Periodical maintenance necessary in transformer to achieve energy conservation:

Proper periodical maintenance leads in Energy conservation

- 1) Check Voltage, current, temperature and other parameters.
- 2) Check for winding resistance.
- 3) Check oil level and dielectric strength of oil.
- 4) Check breather and silica gel.
- 5) Check cooling arrangement.
- 6) Check Insulation resistance.

1 Mark for
each of any
four
= 4 Marks

3 e) State and explain any four commercial losses in transmission and distribution system.

Ans:

Commercial losses in Transmission & Distribution systems:

- i) Power Theft
- ii) Unmetered supply
- iii) Meter inaccuracies.
- iv) Metering discrepancies.
- v) Small unmetered loads.
- vi) Billing issues
- vii) Lower collection efficiency.

i) Theft of electricity:

Theft of electricity has been carried out by the ways of meter tampering and direct hooking. In meter tampering various methods have been carried out such as placing the powerful magnet on the meter, bypassing of meters, disturbing the disc rotation by inserting some material externally, stopping the meter by remote control, change in meter terminals etc. In direct hooking tapping of conductor of LT feeder or tampered service to make unauthorized and unmetered supply

1 Mark for
each of any
four
= 4 Marks



available for them. Power tapped by direct hooking can't be accounted as it is an unmetered consumption.

ii) Unmetered supply:

Unmetered supply used by agriculture pumps is one of the major causes of commercial loss for most of the states. Agriculture tariff is such that it charges consumption per unit of HP of the motor. State government gives subsidy on agricultural consumption hence some utilities deliberately overestimates this unmetered consumption.

iii) Meter inaccuracies:

Losses due to meter inaccuracies are nothing but a difference between actual energy supplied to consumer through the meters and amount registered by meters.

iv) Metering Discrepancies:

Meter to be used for the measurement of electrical energy should be properly calibrated before installation. Defective meters give rise to errors in energy reading, these defects may be due to multiple reasons such as burning of meters, heavy load lead to burning of terminal box. Recording may also be reduced due to wrong CT ratios.

v) Small unmetered loads:

In some sections, energy consumption or usage is estimated in place of measuring it with an energy meter, this gives rise to unmetered losses. This happens in street lightning.

vi) Billing issues:

This is regarding consumer complaints regarding bill not received, late receipt of bill, received wrong bill, different meter reading, wrong applied tariff, wrong calculations.

vii) Lower collection efficiency:

Most of the times utility fail to collect the actual amount billed by them. So it is well obvious that higher commercial losses are inherent to lower collection efficiency.

4. A Attempt any THREE of the following:

12

4 A a) State the objectives of tariff systems.

Ans:

The objectives of tariff:

- 1) Recover capital investment made
- 2) Cost of operation, supplies, maintenance and losses must be recovered.
- 3) The cost recovered must be distributed amongst the consumers.
- 4) Cost of metering, billing, collection and miscellaneous services must be recovered.
- 5) Should have a provision of penalty for low power factor.
- 6) Gain suitable profit on capital investment.
- 7) Discourage users from drawing higher loads than contracted.

1 Mark for
each of any
four
= 4 Marks

4 A b) Define the following terms related to tariff: (i) Connected load (ii) Unit consumed (iii) Fixed charges (iv) Electricity Tax

Ans:

(i) Connected load

It is the sum of the power ratings (Watts or kW or MW) of all devices and machines existing (installed) in the premises of consumer. It is used to decide the fixed charges



Summer – 2018 Examinations

Subject Code: 17506 (ECA)

Model Answers

Page No: 12 of 23

to be levied.

(ii) Unit consumed

It is generally defined as Power (load) in kW used x No. of working hours for particular billing period (generally 1 month), expressed in kWh or Units (1 kWh = 1 Unit)

1 Mark each
= 4 Marks

(iii) Fixed charges

Fixed charges are levied to recover the part of capital investment done by electricity utility. The fixed energy charges depend upon type of consumer 1) single phase or three phase, 2) residential, commercial, Industrial or 3) LT or HT etc.

Fixed charges for HT and some LT industrial or commercial depends on the maximum demand of the consumer.

The consumer has to pay the fixed charges irrespective of the fact whether he has consumed or not consumed electrical energy.

(iv) Electricity Tax:

An amount levied by the state government normally as a percentage of the total electricity bill which includes all amounts that go to the electricity supply agency.

4 A c) What is Time of Day tariff? How it help in energy conservation?

Ans:

Time-off-day tariff:-

- In addition to basic tariff (Maximum Demand Tariff / KVA Maximum Demand Tariff / Load factor tariff /also the tariff in which P.F. of industrial consumer is taken into consideration.), consumer has to pay energy consumption charges according to time of a day for which energy is consumed.
- TOD energy meter is installed in the consumer premises.
- This meter is specially designed to measure energy consumption w.r.t. time.
- This type of tariff is such that energy consumption charges/unit are less during Off-load period
- Energy consumption charges/unit are more during Peak-load period.
- This type of tariff is introduced to encourage industrial consumers to run their maximum load during Off-load period.

2 Marks for
TOD tariff

For Example:

Sr.No	Block	Rate / KWH Rs	Remark
1	8.00 am to 12.00 noon	Rs. 6.00 per unit+0.80 Rs. Per unit	Peak load period
2	12.00 noon to 6.00 pm	Rs. 5.00 per unit+ 0 Rs. Per unit	Base load
3	6.00 pm to 10.00 pm	Rs. 6.00 per unit+ 1.10 Rs. Per unit	Peak load period
4	10.00 pm to 8.00 am	Rs. 5.00 per unit – 1.50 Rs. Per unit	OFF load period

Time-off-day tariff and Energy conservation:

TOD tariff gives opportunity for the user to reduce their billing. During off peak hours they provide an incentive to shift consumption from peak to off peak periods. The off peak hours tariff charges are quite low in comparison to peak hour's tariff. TOD tariff

2 Marks for
explanation



Summer – 2018 Examinations

Subject Code: 17506 (ECA)

Model Answers

Page No: 13 of 23

structure is implemented for industrial consumers as their load demands are very high. As the supply agencies get loaded as much near to the rated load for longer times of the day their overall efficiency gets higher helping to conserve energy.

4 A d) Give classification of co-generation system on the basis of sequence of use and use of technology.

Ans:

Classification of co-generation system:

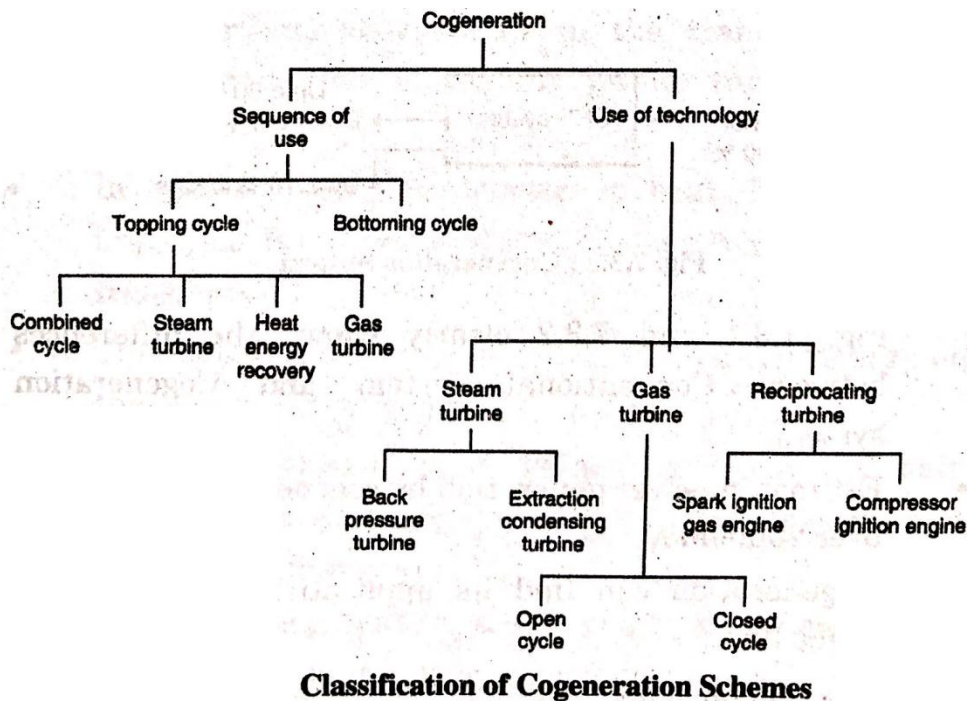

4 Marks for correct classification

B) Attempt any ONE of the following:

4 B a) Explain following techniques related to energy conservation in transmission and distribution system. (i) By balancing phase currents (ii) Variable technical losses (I^2R losses).

Ans:

(i) Balancing Phase currents:

- Proper (healthy balanced) three phase loads always draw equal currents in all lines but single phase loads in the 3 phase 4 wire system or loads connected between two phase lines lead to unequal currents in the lines. This leads to circulating currents in transformers/ neutral conductors due to which losses increase. Hence balancing of such feeder currents is needed to reduce the feeder copper losses.
- As a result of unequal loads on individual lines, sequence components in them cause overheating of transformers, cables, conductors, motors. These increase losses and resulting in motor malfunctioning under unbalanced voltage conditions.

3 Marks



Summer – 2018 Examinations

Subject Code: 17506 (ECA)

Model Answers

Page No: 14 of 23

- Due to unequal loading on the single phase lines of a 3 phase, 4 wire supply system the voltage drops in lines are different that create unequal (non-rated) phase and line voltages at the load leading to unhealthy effects on the loads. Large ovens/furnaces of the single phase and two phase types are such loads. Hence it becomes necessary to equate/balance the three phase/line currents at the supply terminals.
- For furnaces the Scott connection transformers are employed to derive the two phase supply from the three phases which transforms the two phase load equally over the three phases.
- Unequal loading is also created due to unequal lengths of feeders of the three phases. Hence it is necessary to obtain current balance to the maximum.

(ii) Variable technical losses (I^2R losses)

Techniques of Reducing Technical Losses:

- 1) Find out the weakest area of more technical loss in the distribution system.
- 2) Locate distribution transformer near to the load centre.
- 3) Use proper capacity distribution transformer.
- 4) Use energy efficient transformers.
- 5) Use shunt capacitors for reactive power management.
- 6) Use HVDC system for long distance bulk power transmission.
- 7) Use ACSR or bundled conductors instead of solid conductors.
- 8) Reduce overloads on distribution transformer.
- 9) Use reactive power compensation techniques.
- 10) Use power factor controlling devices or techniques.
- 11) Minimize I^2R losses.
- 12) Balance the load currents.
- 13) Regulate the system voltages.

3 Marks

4 B b) State the incentives and penalties related with power factor tariff.

Ans:

Incentives and penalties related with power factor tariff:

In addition to basic tariff (Maximum Demand Tariff / KVA Maximum Demand Tariff / Load factor tariff) the tariff in which P.F. of industrial consumer is taken into consideration is known as Power Factor Tariff.

- If the P.F. of consumer is less than P.F. declare by Supply Company (say below 0.9 Lag.) then penalty will be charged in energy bill.
- If The P.F. of consumer is more than P.F. declare by Supply Company (say above 0.95lag.) then discount will be given in energy bill.
- As usual consumer has to pay actual energy consumption charges
- Application :-
This type of tariff is applicable to industrial consumer/H.T/ commercial consumers with contract demand above 80 kw/ 100Kva/107 hp consumer.
- Incentives and Penalties to Power factor tariff :-

3 Marks each
(Incentives
+Penalty)
= 6 Marks



Summer – 2018 Examinations

Subject Code: 17506 (ECA)

Model Answers

Page No: 15 of 23

Power factor incentive:- e.g.

Power Factor	Percentage of incentive
0.95	0% of energy bill
Above 0.96	1% of energy bill
Above 0.97	2% of energy bill
Above 0.98	3% of energy bill
Above 0.99	4% of energy bill
At unity P.F.	5% of energy bill

Power factor penalty:- e.g.

Power factor lagging	Percentage of penalty
For 0.90 Power factor lagging	0% of energy bill
For 0.89 Power factor lagging	2% of energy bill
For 0.88 Power factor lagging	3% of energy bill
For 0.87 Power factor lagging	4% of energy bill
For 0.86 Power factor lagging	5% of energy bill
For 0.85 Power factor lagging	6% of energy bill
For 0.84 Power factor lagging	7% of energy bill
For 0.83 Power factor lagging	8% of energy bill
For 0.82 Power factor lagging	9% of energy bill
For 0.81 Power factor lagging	10% of energy bill

5 Attempt any FOUR of the following:

16

5 a) Explain the “mitigation of power theft” and “faulty meter replacement” for energy conservation techniques to reduce commercial losses.

Ans:

Energy conservation techniques to reduce commercial losses:

1. **Mitigation of Power Theft:** Power theft being the most important issue which all of the service providing utilities face. It necessitates some strong steps towards mitigation of power theft. State government can contribute in this by forming strict rules and laws.

2 Marks for
Any 2 points

i) **Meter Seal:** CT/PT terminals at meter terminal box should be provided with proper seal management in order to prevent power theft. Severe penalties should be imposed for meter tampering.

ii) **Vigilance squad:** Areas of power theft should be identified and vigilance squad needs to be formed for power theft checking in order to speed up mitigation.



Summer – 2018 Examinations

Subject Code: 17506 (ECA)

Model Answers

Page No: 16 of 23

2. Faulty meter replacement :-

- i) Replacement: Distribution agency should pay attention to faulty or sluggish meters. It should be replaced by newer & advanced meters.
- ii) Checking: Meter should not only be installed but also it is necessary to check periodically for the purpose of knowing accuracy.
- iii) Advanced Meters: Old inaccurate electromechanical meters should be replaced with latest microprocessor based digital meters so that energy consumption can be accurately measured.
- iv) Prepaid Metering: Prepaid metering encourages efficient use of power especially for agricultural sector. Prepaid meters may prove effective measures against unauthorized abstraction of energy.

2 Marks for Any 2 points

5 b) With neat diagram explain the following terms:

- (i) Steam turbine co-generation system
- (ii) Gas turbine co-generation system

Ans:

(i) Steam turbine co-generation system:

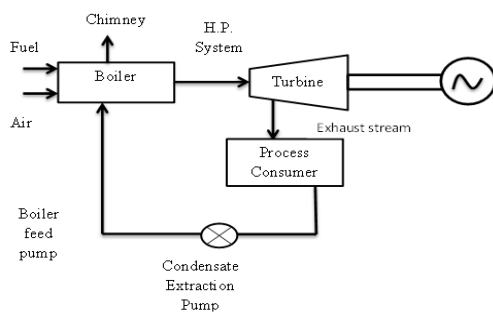

Fig: Back pressure steam turbine cogeneration

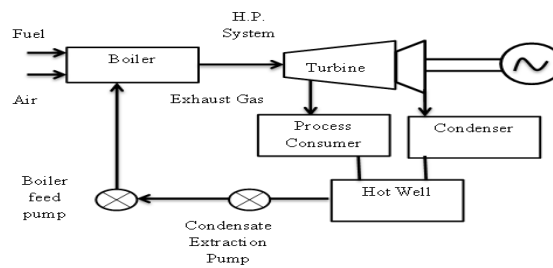
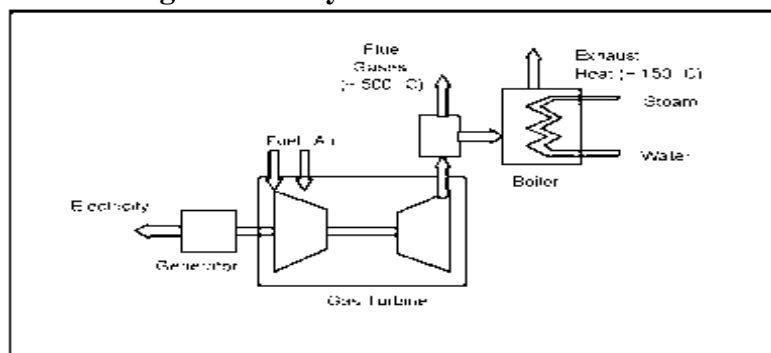

Fig:- Extraction condensing turbine Cogeneration

The two types of steam turbines most widely used are the backpressure and the extraction. Another variation of the steam turbine topping cycle cogeneration system is the extraction-back pressure turbine that can be employed where the end-user needs thermal energy at two different temperature levels. The full-condensing steam turbines are usually incorporated at sites where heat rejected from the process is used to generate power. The specific advantage of using steam turbines in comparison with the other prime movers is the option for using a wide variety of conventional as well as alternative fuels such as coal, natural gas, fuel oil and biomass. The power generation efficiency of the demand for electricity is greater than one MW up to a few hundreds of MW. Due to the system inertia, their operation is not suitable for sites with intermittent energy demand.

ii) Gas turbine co-generation system



Any one Labeled diagram 1 Mark and 1 Mark of for explanation = 2 Marks

1 Mark for diagram

Gas turbine cogeneration systems can produce all or a part of the energy



Summer – 2018 Examinations

Subject Code: 17506 (ECA)

Model Answers

Page No: 17 of 23

requirement of the site. The energy released at released at height temperature in the exhaust stack be recovered for various heating cooling applications. The typical range of gas turbines varies from a fraction a MW to around 100 MW. Gas turbine cogeneration has probably experienced the most rapid development in the recent years due to the greater availability of natural gas, rapid progress in the technology, significant reduction in installation costs, & better environment performance. Gas turbine has a low short start up time and provides the flexibility of intermittent operation. Though it has a low heat to power conversion efficiency more heat can be recovered at higher temperatures. If the heat output is less than that required by the user it is possible to have supplementary natural gas firing by mixing additional fuel to the oxygen rich exhaust gas to boost the thermal output more efficiently . Steam generated from the exhaust gas of the gas turbine is passed through a backpressure of extraction condensing steam turbine to generate additional power. The exhaust or the extracted steam from the steam turbine provides the required thermal energy.

1 Mark for Explanation

5 c) With neat diagram explain use of “reactive power controller” to reduce technical losses in transmission and distribution system.

Ans:

Reactive power compensation in Transmission and Distribution systems:

- The reactive power is present in lines due to the reactive loads and device/component reactance.
- This leads to heavy currents for active power transmission that result in overheating of transmission systems etc. and hence fall in the system efficiency.
- Reactive power compensation leads to reduction of line/system current due to which the inherent current related power losses (I^2R) in the system are reduced, leading to increase in the system efficiency and improvement in the power quality.
- Also as reactive power is compensated (leading to its reduction) the power factor is improved.
- Thus energy is conserved as the losses in the lines are minimized and the excess magnetizing current for increasing the voltage is avoided leading to savings. Diagram shows a scheme of reactive power compensation used in transmission and distribution systems.
- The Fig. below shows the static VAR compensator, in which the inductors and capacitors are switched to the line as per the requirement of lagging or leading reactive VA.

2 Marks for explanation

2 Mark diagram (other equivalent diagram to be evaluated on merit and correctness)

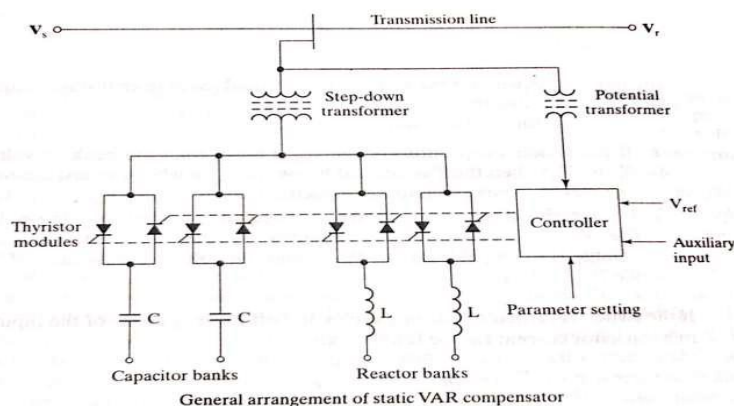



Summer – 2018 Examinations

Subject Code: 17506 (ECA)

Model Answers

Page No: 18 of 23

- 5 d) Draw block diagram of microprocessor based centralized control equipment of energy conservation and explain it.

Ans:

Microprocessor based centralized control equipment of energy conservation:

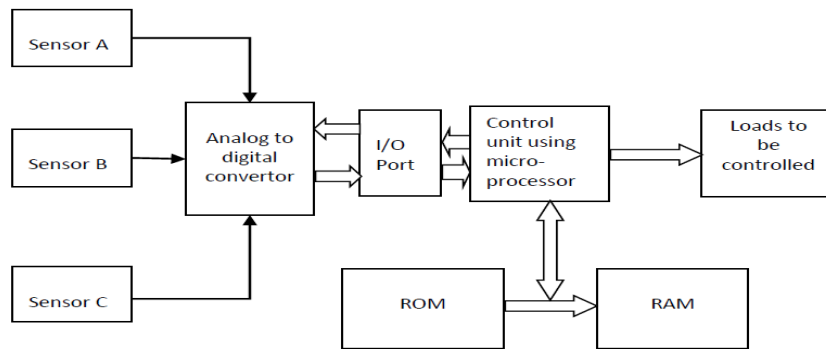

The sensors are employed to get the values/levels of quantities to be controlled like intensity of light, speed of machine, temperature etc. These sensors may be for position, temperature, light etc. The signals from the sensors are converted to digital form and fed to the microprocessor, which determines the requisite actions needed for implementing energy conservation settings by fetching data for comparison from the ROM and carrying out internal actions for decision making by calculations/comparison using the RAM. The requisite signals are given to the control gear for controlling loads.

Labeled
Diagram 2
Marks (other
equivalent
diagram to
be
evaluated on
merit and
correctness),

2 Marks for
explanation
= 4 marks

- 5 e) State any four advantages of soft starter.

Ans:

Advantages of soft starter:

1. Very low line voltage drops on motor operation
2. Reduced energy losses in the lines
3. System efficiency increases
4. Very smooth starting & operation
5. As current is limited, the maximum demand is controlled
6. Prevents damage to motor through mechanical stress
7. Severe spikes of starting currents are eliminated.
8. Loss of energy during starting is minimized to about 40 to 50%.
9. Severe wear and tear of mechanical parts such as bearing etc. during starting is eliminated leading to longer life of bearings and other related components.
10. Very low mechanical stress.
11. As starting currents are highly inductive, limiting their magnitudes results in improved power factor.
12. As current peaks are controlled the MD is reduced which may lead to lower MD billing.
13. Less mechanical maintenance.
14. Saving in operating costs.

1 Mark for
each of any
four
advantages
= 4 Marks

- 5 f) What is energy flow diagram? State its significance from Energy Audit point of view.

Ans:

Example energy flow diagram:



Summer – 2018 Examinations

Subject Code: 17506 (ECA)

Model Answers

Page No: 19 of 23

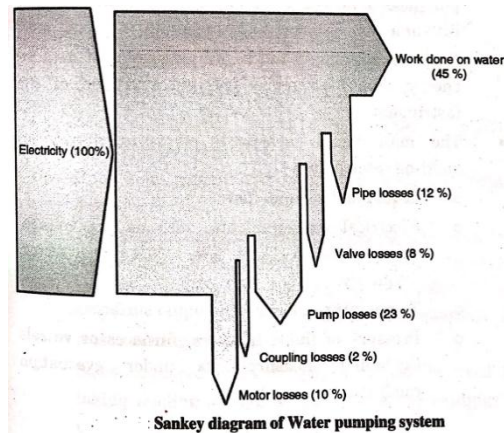
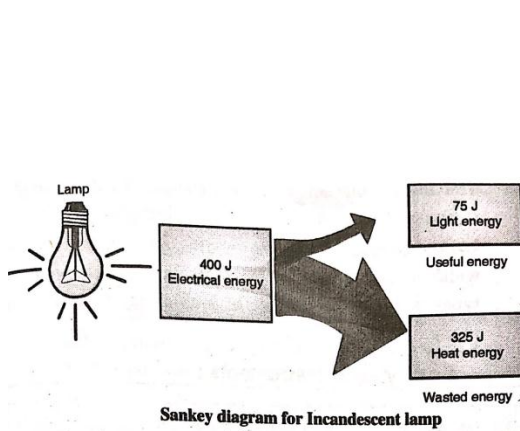

Any one Labeled Diagram 2 marks (other equivalent diagram to be evaluated on merit and correctness),

Significance of energy flow diagram:

1. Energy flow diagram, also known as Sankey diagram, is a specific type of flow diagram in which the width of the arrow is proportional to quantity of energy.
2. Length of the arrows has no bearings with the quantity of energy.
3. These diagrams indicate the flow of energy in a process and help identifying the quality and quantity of energy.
4. The input of energy begins from left of the diagram. The outputs (useful and leakages/losses of energy) are shown in diagram.

2 Marks for explanation

6 Attempt any FOUR of the following:

16

- 6 a) With a neat diagram, explain back pressure steam turbine co-generation system.

Ans:

Back pressure steam turbine co-generation system:

In this type steam enters the turbine chamber at High Pressure and expands to Low or Medium Pressure. Enthalpy difference is used for generating power / work. Depending on the pressure (or temperature) levels at which process steam is required, backpressure steam turbines can have different configurations as shown in Figure. In extraction and double extraction backpressure turbines, some amount of steam is extracted from the turbine after being expanded to a certain pressure level. The extracted steam meets the heat demands at pressure levels higher than the exhaust pressure of the steam turbine. The efficiency of a backpressure steam turbine cogeneration system is the highest. In cases where 100 per cent backpressure exhaust steam is used, the only inefficiencies are gear drive and electric generator losses, and the inefficiency of steam generation. Therefore, with an efficient boiler, the overall thermal efficiency of the system could reach as much as 90 percent.

2 Marks for explanation

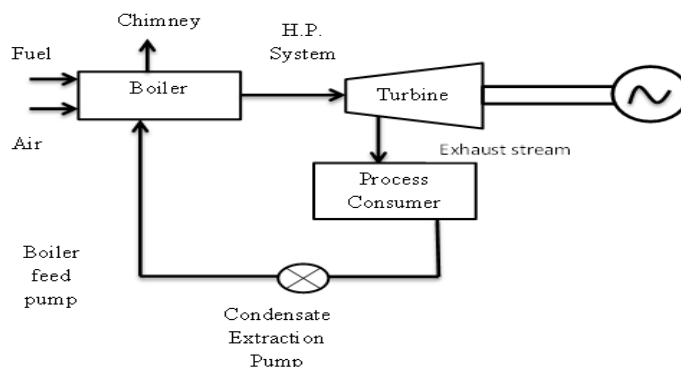

Labeled Diagram 2 Marks (other equivalent diagram to be evaluated on merit and correctness)



Summer – 2018 Examinations

Subject Code: 17506 (ECA)

Model Answers

Page No: 20 of 23

6 b) With a neat diagram, explain gas engine co-generation system.

Ans:

Gas engine co-generation system:

Spark Ignition Gas Engine:

These engines have shaft efficiency near about 35% but low capital cost/kW comparing to compression ignition engine. Temperature range of 70-80 C can be obtained at the engine cooling system which is possible to increase till 110C. Sizes of the engine may range up to 4 MW. Spark ignition engines are used to extract low pressure steam or medium or low temperature hot water on site.

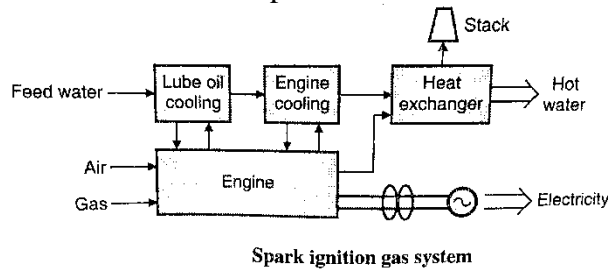

2 Marks for diagram
+
2 Marks for explanation
=4 Marks
(Any one system to be considered)

OR

Compression Ignition Engine:

These are suitable for large co-generation plants. Shaft efficiency is in the range of 35-40%. These are direct injection engines which may employ turbochargers, intercoolers on fittings. This system offers flexibility to make use of an alternative fuel that is oil. Full output can be derived using the same which proves useful for curtailing the cost of gas tariff. Compression ignition engines require complex cooling system as compared to spark ignition gas engine.

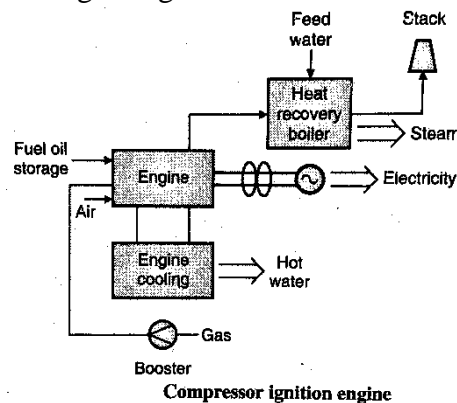

6 c) Enlist any four energy audit instruments and also give their functions.

Ans:

Energy audit instruments and their functions:

S.N.	Name of Instruments	Function (To measure)
1	Power Analyzer, Digital Multimeter	All elect. parameters (V, I, P, R)
2	Lux Meter	Lamp output
3	Electronic Combustion Analyzer	Combustion of fuel
4	Flow meter	Liquid flow
5	Thermometer and Temperature indicator	Process temperature
6	Power Analyzer	Presence of harmonics

1 Mark for each of any four instruments with function
=4 Marks



Summer – 2018 Examinations

Subject Code: 17506 (ECA)

Model Answers

Page No: 21 of 23

7	Fuel efficiency Monitor	Fuel efficiency
8	Gas leak Detector	Gas leak
9	Digital Tachometer and Stroboscope	Speed of rotating device

6 d) Explain stepwise the “Detailed energy audit” procedure.

Ans:

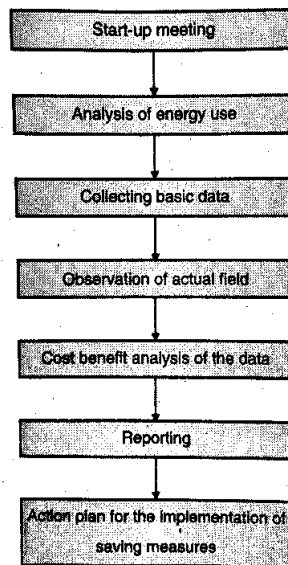

Flow Chart of Energy Audit Procedure

2 Marks for
Flowchart or
steps

- A) **Start up meeting:** For this programme, we proceed with this meeting. If then continue us until implementation of energy saving measures.
- B) **Analysis of energy used:** Identify where energy used & it shows on which area should be concentrate.
- C) **Collecting basic data:** At site load, some of the following important points:
1. Operating hours 2. Duty cycle 3. Actual power consume
- D) **Observation of actual field:** After collecting data, we start actual field work. It means we have find out process where energy saving can be done. Always apply the 80 by 20 rule. It means concentrate on opportunities that require 20% input & givens 80% of the saving.
- E) **Cost benefit analysis of the data:** The energy conservation opportunities analysis should be in terms of cost of carrying out that project v/s the benefit that can be earned.
- F) **Reporting:** We have to submit the detail report. Then we have to take sanction of that report from final Authority.
- G) **Action plan:** In this all the measure steps must be included in the action plan for the proper implementation.

2 Marks for
explanation

OR

- 1. Collect information about the plan:** In this information, the measured energy used, raw material required & components required for the plant are considered.
- 2. Collect production process:** In this process, the design the flowchart of production process, the schedule of operation & its time frame is also considered.
- 3. Energy and utility system:** In this step, load variation in pumps, fans & compressors are considered, the analysis of energy loss and measurement of insulation level is also considered.



Summer – 2018 Examinations

Subject Code: 17506 (ECA)

Model Answers

Page No: 22 of 23

4. **Bridge description of each utility:** In this step, the electricity the steam, water, cooling water and compressed air is to be considered.
5. **Detailed process flow diagram:** In this step the flow chart, the flow rate & boiler efficiency is to be considered.
6. **Energy efficiency in utility & process system:** In this step, consider the following things: i) specific energy consumption, ii) furnace, iii) DG set performance analysis, iv) lighting system.
7. **Energy conservation option & recommendation:** The energy conservation & recommendation of better energy source is to be considered.

- 6 e) Define and explain the procedure to calculate the payback period. Also state its significance.

Ans:

Procedure to calculate the payback period:

A] Steps to calculate saving for Kw load

a) Calculation for old system:

i) Calculate load per day

$$= (\text{Consumption per fixture} \times \text{Total fixture} \times \text{working Hours}) / 1000$$

ii) Calculate load per month = Load per day X Working days per month

iii) Calculate consumption per month = Load per month(kW) X unit rate(Rs/kW)

b) Calculations for proposed system:

i) Load per day = (Consumption per fixture X Total fixture X working Hours) / 1000

ii) Load per month = Load per day X Working days per month

iii) Consumption per month = Load per month(kW) X unit rate(Rs/kW)

c) Calculate cost saving per month

$$= (\text{old system consumption per month}) - (\text{Proposed system consumption per month})$$

d) Calculate cost saving per year = 12 x Saving per month

B] Saving for VA load :

i) Calculation for old system:-

$$\text{Calculate VA} = W / P.f.$$

$$\text{Total kVA load for all the fixtures} = \text{VA} \times \text{No of fixtures} / 1000$$

ii) Calculation for proposed system:-

$$\text{Total kVA load for all the fixtures} = \text{VA} \times \text{No of fixtures} / 1000$$

iii) Saving:

Total kVA load saving for all the fixtures = (Total kVA load of old system for all the fixtures) – (Total kVA load of proposed system for all the fixtures)

$$\text{Monthly Demand charges saving} = (\text{Total kVA load saving for all the fixtures}) \times (\text{Maximum demand charges per kVA in Rs.})$$

$$\text{Yearly demand charges saving} = 12 \times (\text{Monthly demand charges saving})$$

Calculations for Payback period in years:

i) Calculate total investment for new system

ii) Payback period in years = Investment / Total Saving

Significance of payback period:

The payback period is an evaluation method used to determine the amount of time required for the cash flows from a project to pay back the initial investment in the project.

The most significant advantage of the payback method is its simplicity. It's an easy way to compare several projects and then to take the project that has the shortest payback time.

3 Marks for explanation of procedure to calculate payback period

1 Mark for significance



MAHARASHTRA STATE BOARD OF TECHNICAL EDUCATION
(Autonomous)
(ISO/IEC-27001-2013 Certified)

Subject Code: 17506 (ECA)

Summer – 2018 Examinations
Model Answers

Page No: 23 of 23